



STARCYL

AIR CYLINDERS

...To boldly go where no cylinder
has gone before ...



- ☑ N.F.P.A. Interchangeable.
- ☑ Heavy Duty Air Cylinders
- ☑ Flush Mount standard.
- ☑ 11 Bore sizes From 1.5" through 12"
- ☑ Strokes - available to any practical length
- ☑ 18 standard Mounting Styles
- ☑ Adjustable Air Cushion Standard
- ☑ 250 PSI AIR/OIL
- ☑ Two Year Warranty
- ☑ Economic Design

STAR3 SERIES



STAR3 CYLINDERS - Design Features

Born to Be an Heavy Duty Air Cylinder !

Piston Rod

High Strength steel. STARNITE (Nitrocarburation) treatment on the rod gives better corrosion-resistant properties (out performs 12-micron, (.0005 in.) chromium electroplating by ratio up to 20:1.), Improved wear resistance, better lubrication retention, dent resistance without induction hardening (60Rc), environmentally friendly, no surface pitting, flaking, or hydrogen embrittlement. The finish created by the process is a lustrous black. (Available in Stainless Steel)

Tie rods

Corrosion resistant STARNITE (Nitrocarburation), stress proof steel maintains uniform compression on tube end seals. (Available in Stainless Steel)

Solid Aluminum Head & Cap

Machined from solid aluminum bar stock (6061 T6) and black anodized for corrosion resistance. (Available in Stainless Steel)

Hard Anodized ID Aluminum Tube

(60 Rc) Provides superior wear resistance, and lower friction coefficient for maximum seal life. (Available in Stainless Steel)

Piston

Machined from solid aluminum bar stock (6061-T6) Offers long bearing support

Cushion Spud

Machined from Steel and STARNITE for hardness and corrosion resistance, to ensure min wear and constant dampening of the piston thru time.

Check seal Cushion and Needle valves

(No charge adders - Standard on 1½" to 5" Bore) Precision Cushion spuds combine with a new style of floating cushion seal provide smooth deceleration at end of the stroke. Needle valves make adjustments easy. (brass or stainless steel)

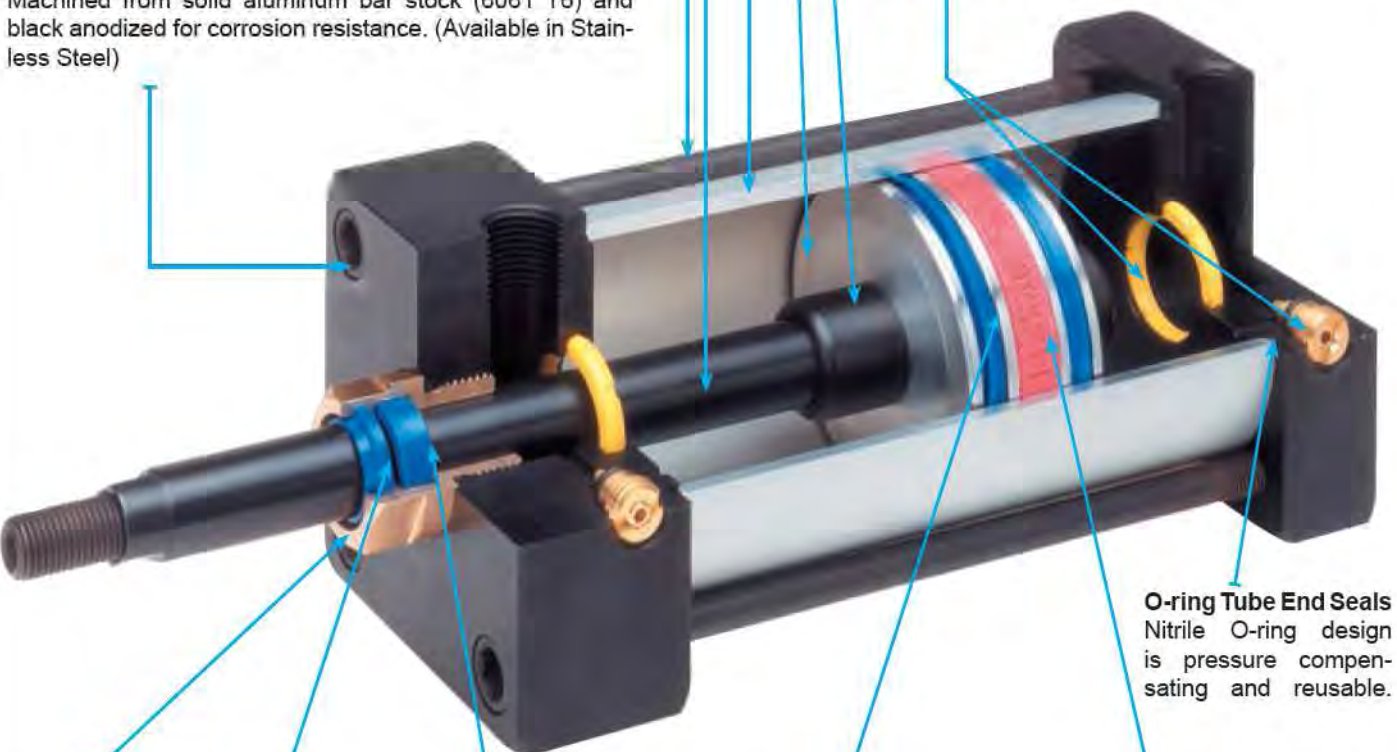

O-ring Tube End Seals
Nitrile O-ring design is pressure compensating and reusable.

Rod Gland

Bronze Or Starnite Cast iron gland is externally removable without cylinder disassembly for easy maintenance. Designed to provide maximum rod bearing. (Also available in Acetal,)

Wiper

The New Wiper wipes dirt out for less maintenance and longer life of the cylinder. (Urethane) (temperature: -50° to 230°F)

Rod lips seal

Our New Design with a real rod u-cup is completely self compensating for zero leakage at all pressures (all seals can be used in a non lube application) (temperature: -50° to 230°F)

Piston Seal

Lip-type low friction urethane piston seals are pressure energized and wear compensating for low friction and long life (temperature: -50° to 230°F) (Viton™ also Available up to 400°F) (all seals can be used in a non lube application)

Piston Wear Ring

Nylon material is designed for low friction, and to ensure minimum wear in the cylinder's tubing in side load application. Eliminates metal-to-metal contact.

*All Blue seals can withstand most chemical washdown, No Fluorocarbon Required

STARNITE THE ANSWER TO WEAR, CORROSION AND FATIGUE PROBLEMS

The STARNITE process improves component properties.

High wear resistance, as well as excellent sliding and running properties, is obtained through STARNITE treatment. The service life of cylinders parts is extended. The finish created by the STARNITE process is a lustrous black.

During the process, which takes place at 1075°F, the metal surface is enriched with nitrogen and carbon. A two part nitride layer consisting of a monophase compound layer and a diffusion layer is formed. Total depth ranges from 0.008-0.040", depending on composition of the base material and treating time. Hardness in the compound layer ranges from approximately HV 700 (60 Rc) to about HV 1600 for high alloyed tools steel. As part of the salt-bath nitriding and QPQP (Quench-Polish & Quench & Polish) sequence, finish-machine parts are polished and chemically processed to produce a highly corrosion-resistant surface with a finish suitable for bearing or seal-type applications.

ENVIRONMENTALLY & ECONOMICALLY SAFE

Great concern exists in North America community regarding many critical materials because of North America' reliance on metals that are not native to this continent. Some 91% of the chromium used here is imported (9% balance from recycling). STARNITE process provides at least a partial solution to this problem and because it is not a plating or a coating but in the steel itself the process offers superior performance.

Corrosion resistance developed by the STARNITE technique out performs 12-micron (.0005 in.) chromium electroplating by ratio up to 20:1, and 20 micron (.0008 in.) nickel plating by a factor of 8:1.

Corrosion Resistance Evaluation
Test conditions; Spool Shaft, ASTM B-117,
(88h) test hours

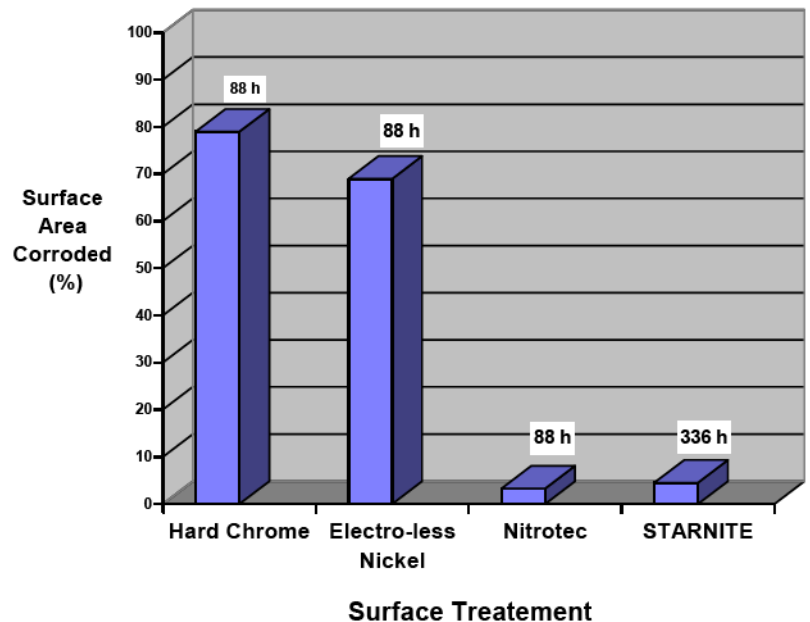

Chrome plated Vs STARNITE

Chromed plated cylinders	STARNITE Process on cylinders
<ul style="list-style-type: none"> • Chrome plate can flake and blister. • Flakes and slivers will destroy seals and glands. • Loose chrome will cause massive leaking and rapid system failure. • Chrome lacks dimensional uniformity. 	<ul style="list-style-type: none"> • Superior corrosion resistance. • Improved wear resistance. • Better lubrication retention. • Dent resistance without induction hardening. • Environmentally Friendly • No surface pitting, flaking, or hydrogen embrittlement. • INCREASED SERVICE LIFE.

STAR3 CYLINDERS - IR IMPACT REDUCTION, how it works ...

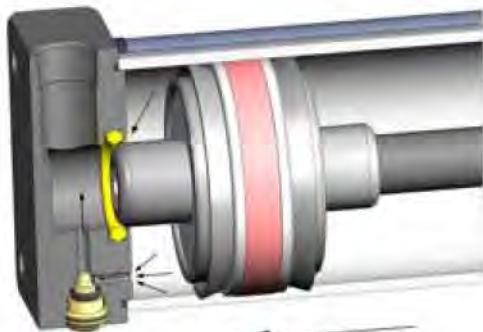

FIG 1

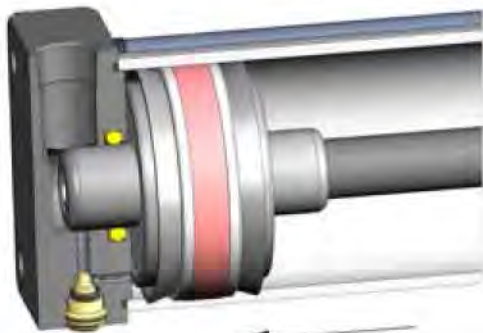

FIG 2

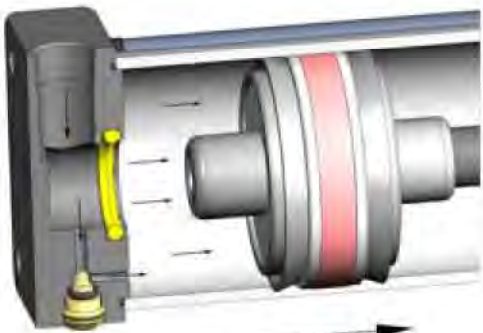

FIG 3

The cushioning process begins when the Cushion piston (Spud) enters the dynamic sealing lips (Fig 1.). The seal moves to the back of the groove creating a seal on the inside diameter and on the back of the cushion seal. The exhaust port is closed by the cushion seal. Pressure increases between the piston and the cushion seal due to the movement of the piston toward the end of the cylinder. Cushioning is adjusted by controlling the flow through a throttle port which is regulated by the needle valve.

In addition the Starcyl IMPACT REDUCTION PISTON design includes special lip seals u-cup containing a dampening ring (bumper) which absorbs the remaining kinetic shock vibration and noise created by the impact (Fig. 2) giving a softer and quieter impact. With this design the cycle time can be increased by opening the needle valve of the air cushioning and let the bumpers absorb the rest. The Option NAC "non adjustable cushion" can be also ordered which reduces the restriction of the needle valve.

The return pressure moves the cushion axially (Fig. 3) until the stop cams reach the front of the groove. The pressure is allowed to by-pass the outside diameter of the seal to allow constant acceleration. In the same time, the Bumper seal releases its compressive energy to propel the piston away from the end cap, producing an immediate breakaway.

The spud on the other end of the piston enters the cushion seal on the head end and then the process starts over again.

Effect of IR option on total stroke of cylinders

PSI	CYLINDER BORE					
	1.5	2.0	2.5	3.25	4.0	5.0
0	0.14	0.15	0.17	0.19	0.22	0.25
20	0.10	0.10	0.12	0.14	0.16	0.18
40	0.07	0.07	0.08	0.09	0.10	0.12
60	0.04	0.04	0.05	0.05	0.06	0.07
80	0.02	0.02	0.02	0.02	0.03	0.03
100	0.00	0.00	0.00	0.00	0.00	0.00

BORE	AREA	ROD SIZE	ROD AREA
(IN.)	(SQ. IN.)	(IN.)	(SQ.IN.)
1.50	1.76	5/8	0.307
2.00	3.14	5/8	0.307
2.50	4.90	5/8	0.307
3.25	8.29	1	0.785
4.00	12.56	1	0.785
5.00	19.64	1	0.785
6.00	28.27	1 3/8	1.485
7.00	38.48	1 3/8	1.485
8.00	50.26	1 3/8	1.485
10.00	78.54	1 3/4	2.405
12.00	113.10	2	3.14

SELECTING BORE SIZE

The following formula may be used in the selection of the proper bore size:

- Extended (push) force in pounds =
(bore area in sq. in.) x (pressure in psi)
- Retract (pull) force in pounds =
(bore area in sq. In.) - (Rod area in sq. In.) x (pressure in psi)

Example: 3 1/4 bore, standard rod size 1" & shop air pressure of 90 psi

Push force: 8.296 (sq. in.) x 90 (pound / sq. In.) = 746.64 pounds

Pull force: 8.296 (sq. In.) - 0.785 (sq. In.) x 90 (pound / sq. In.) = 675 pounds

STAR3 CYLINDERS - NFPA MOUNTS

TABLE OF CONTENTS :

Star 3 Aluminum Construction 1 1/2 to 12" bore Cylinder features

Technical features	page 2
StarNite (nitro-Carburation)	page 3
Impact Reduction	page 4

Standard Rod Size

ST3	Basic Mount dimensions	page 6
ST3D	Double rod	page 7
ST3S4	Side Tapped	page 7
ST3F1 - F2	Front & Rear Flange	page 8
ST3X1, X2 & X3	Tie Rods Extended Both, Rear & Front	page 8
ST3P1, P2 & P4	Clevis Mounts	page 9
ST3T1, T2 & T4	Trunnion Mounts	page 10
ST3S2 & S2E	Side Lugs Mounts	page 11
ST3S1	Front Angle Mount	page 12
ST3S7	End Lugs Mount	page 12
ST3E3, E4	Square Flange Front & Rear	page 13

Oversize Rod Size

ST3O	Basic Mount dimensions	page 14
ST3OD	Double rod	page 15
ST3OS4	Side Tapped	page 15
ST3OF1 - F2	Front & Rear Flange	page 16
ST3OX1, X2 & X3	Tie Rods Extended Both, Rear & Front	page 16
ST3OP1, P2 & P4	Clevis Mounts	page 17
ST3OT1, T2 & T4	Trunnion Mounts	page 18
ST3OS2 & S2E	Side Lugs Mounts	page 19
ST3OS1	Front Angle Mount	page 20
ST3OS7	End Lugs Mount	page 20
ST3OE3, E4	Square Flange Front & Rear	page 21

Model Detail

ST3BB	Back To Back	page 22
ST3MP	Multi-Position	page 23
ST3TD	Tandem	page 24
ST3TKS1	Air/Oil Tank Angle Mount	page 25
ST3TKS4	Air/Oil Tank Side Tap Mount	page 26

Non Rotating/Slide

-NRE	Non Rotating	Page 27
-NRED	Non Rotating Double	Page 27

Accessories

.....	page 28
Rod and Stop tube Selection	page 29
Stop tube Design	page 30
Alignment Couplers	page 30
Switches Reed & Hall Effect	page 31

Options in detail

.....	Page 32
-------	---------

HOW TO ORDER

.....	page 35
-------	---------



ST3 Page 6
ST3O page 14
Basic Mount (MX0)



ST3D page 7
ST3OD page 15
Double rod



ST3S4 page 7
ST3OS4 page 15
Bottom Tap (MS4)



ST3F1 Page 8
ST3OF1 page 16
Front Flange (MF1)



ST3F2 page 8
ST3OF2 page 16
Rear Flange (MF2)



ST3X1 page 8
ST3OX1 page 16
Tie Rods Extended Both Ends (MX1)



ST3X2 page 8
ST3OX2 page 16
Tie Rods Extended Cap End (MX2)



ST3X3 page 8
ST3OX3 page 16
Tie Rods Extended Head End (MX3)



ST3P1 page 9
ST3OP1 page 17
Short Clevis (MP1)



ST3P2 page 9
ST3OP2 page 17
Detachable Clevis (MP2)



ST3P4 page 9
ST3OP4 page 17
Pivot Eye Clevis (MP4)



ST3T1 page 10
ST3OT1 page 18
Head Trunnion (MT1)



ST3T2 page 10
ST3OT2 page 18
Cap Trunnion (MT2)



ST3T4 page 10
ST3OT4 page 18
Mid Trunnion (MT4)



ST3S2 page 11
ST3OS2 page 19
Detachable Side Lug (MS2)



ST3S2E page 11
ST3OS2E page 19
Fixed Side Lug (MS2)



ST3S1 page 12
ST3OS1 page 20
Front Angle (MS1)



ST3S7 page 12
ST3OS7 page 20
End Lug (MS7)



ST3E3 page 13
ST3OE3 page 21
Head Square Flange (ME3)



ST3E4 page 13
ST3OE4 page 21
Cap Square Flange (ME4)

STAR3 CYLINDERS - Standard Rod Diameters

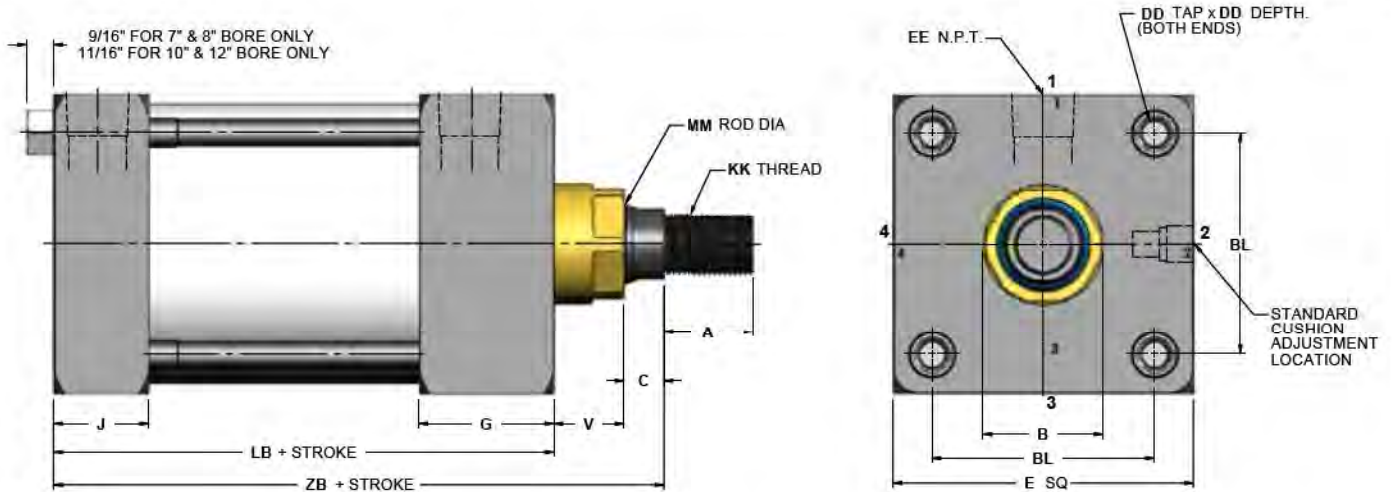

BORE	A	B	BL	C	DD	DD depth*	E	EE	G	J	KK	LB	MM	V	ZB
1.5	3/4	1.123	1.43	3/8	1/4-28	0.50	2	3/8	1 1/2	1	7/16-20	3 5/8	5/8	5/8	4 5/8
2.0	3/4	1.123	1.84	3/8	5/16-24	0.50	2 1/2	3/8	1 1/2	1	7/16-20	3 5/8	5/8	5/8	4 5/8
2.5	3/4	1.123	2.19	3/8	5/16-24	0.50	3	3/8	1 1/2	1	7/16-20	3 3/4	5/8	5/8	4 3/4
3.25	1 1/8	1.498	2.76	1/2	3/8-24	0.63	3 3/4	1/2	1 3/4	1 1/4	3/4-16	4 1/4	1	7/8	5 5/8
4.0	1 1/8	1.498	3.32	1/2	3/8-24	0.63	4 1/2	1/2	1 3/4	1 1/4	3/4-16	4 1/4	1	7/8	5 5/8
5.0	1 1/8	1.498	4.10	1/2	1/2-20	0.75	5 1/2	1/2	1 3/4	1 1/4	3/4-16	4 1/2	1	7/8	5 7/8
6.0	1 5/8	1.998	4.88	5/8	1/2-20	0.75	6 1/2	3/4	2	1 1/2	1-14	5	1 3/8	1	6 5/8
7.0	1 5/8	1.998	5.73	5/8	5/8-18	0.75	7 1/2	3/4	2	1 1/2	1-14	5 1/8	1 3/8	1	6 3/4
8.0	1 5/8	1.998	6.44	5/8	5/8-18	0.75	8 1/2	3/4	2	1 1/2	1-14	5 1/8	1 3/8	1	6 3/4
10.00	2	2.373	7.92	3/4	3/4-16	1.00	10 5/8	1	2 1/4	2	1 1/4-12	6 3/8	1 3/4	1 1/8	8 1/4
12.00	2 1/4	2.623	9.41	7/8	3/4-16	1.00	12 3/4	1	2 1/4	2	1 1/2-12	6 7/8	2	1 1/8	8 7/8

*Can be use for front or rear Mount direct with the face of the cylinder

ROD END STYLE

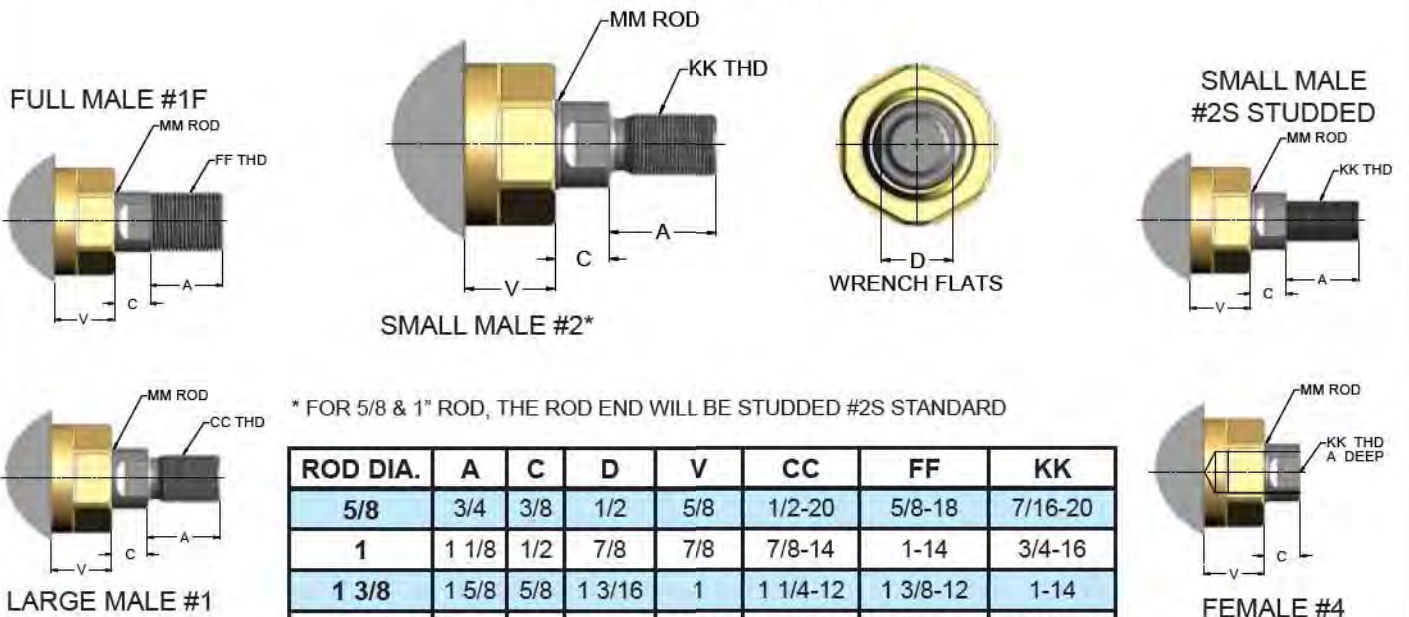

* FOR 5/8 & 1" ROD, THE ROD END WILL BE STUDDED #2S STANDARD

ROD DIA.	A	C	D	V	CC	FF	KK
5/8	3/4	3/8	1/2	5/8	1/2-20	5/8-18	7/16-20
1	1 1/8	1/2	7/8	7/8	7/8-14	1-14	3/4-16
1 3/8	1 5/8	5/8	1 3/16	1	1 1/4-12	1 3/8-12	1-14
1 3/4	2	3/4	1 1/2	1 1/8	1 1/2-12	1 3/4-12	1 1/4-12
2	2 1/4	7/8	1 3/4	1 1/8	1 3/4-12	2-12	1 1/2-12

STAR3 CYLINDERS

DOUBLE ROD END (ST3D)

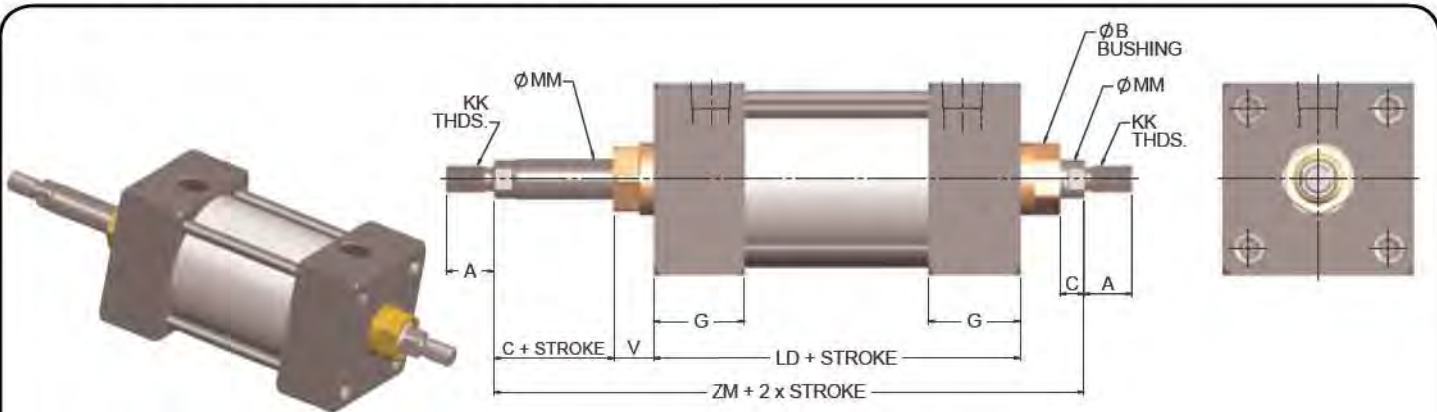

BORE	A	B	C	E	G	R	V	EE	LD	KK	MM	ZM
1 1/2	3/4	1.123	3/8	2	1 1/2	1.43	5/8	3/8	4 1/8	7/16-20	5/8	6 1/8
2	3/4	1.123	3/8	2 1/2	1 1/2	1.84	5/8	3/8	4 1/8	7/16-20	5/8	6 1/8
2 1/2	3/4	1.123	3/8	3	1 1/2	2.19	5/8	3/8	4 1/4	7/16-20	5/8	6 1/4
3 1/4	1 1/8	1.498	1/2	3 3/4	1 3/4	2.78	7/8	1/2	4 3/4	3/4-16	1	7 1/2
4	1 1/8	1.498	1/2	4 1/2	1 3/4	3.32	7/8	1/2	4 3/4	3/4-16	1	7 1/2
5	1 1/8	1.498	1/2	5 1/2	1 3/4	4.12	7/8	1/2	5	3/4-16	1	7 3/4
6	1 5/8	1.998	5/8	6 1/2	2	4.88	1	3/4	5 1/2	1-14	1 3/8	8 3/4
7	1 5/8	1.998	5/8	7 1/2	2	5.73	1	3/4	5 5/8	1-14	1 3/8	8 7/8
8	1 5/8	1.998	5/8	8 1/2	2	6.44	1	3/4	5 5/8	1-14	1 3/8	8 7/8
10	2	2.373	3/4	10 5/8	2 1/4	7.92	1 1/8	1	6 5/8	1 1/4-12	1 3/4	10 3/8
12	2 1/4	2.623	7/8	12 3/4	2 1/4	9.41	1 1/8	1	7 1/8	1 1/2-12	2	11 1/8

BOTTOM TAP MOUNT (NFPA MS4)

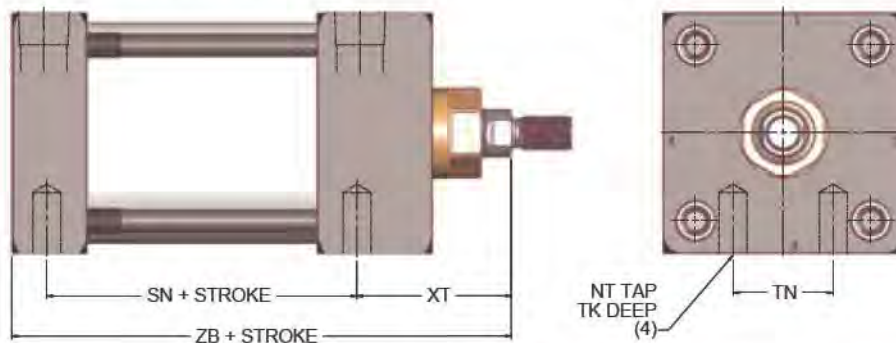

MODEL ST3S4

BORE	NT	TK	TN	SN	XT	ZB
1 1/2	1/4-20	3/8	5/8	2 1/4	1 15/16	4 5/8
2	5/16-18	1/2	7/8	2 1/4	1 15/16	4 5/8
2 1/2	3/8-16	5/8	1 1/4	2 3/8	1 15/16	4 3/4
3 1/4	1/2-13	3/4	1 1/2	2 5/8	2 7/16	5 5/8
4	1/2-13	3/4	2 1/16	2 5/8	2 7/16	5 5/8
5	5/8-11	1	2 11/16	2 7/8	2 7/16	5 7/8
6	3/4-10	1 1/8	3 1/4	3 1/8	2 13/16	6 5/8
7	3/4-10	1 1/8	3 1/2	3 1/4	2 13/16	6 3/4
8	3/4-10	1 1/8	4 1/2	3 1/4	2 13/16	6 3/4
10	1-8	1 1/2	5 1/2	4 1/8	3 1/8	8 1/4
12	1-8	1 1/2	7 1/4	4 5/8	3 1/4	8 7/8

STAR3 CYLINDERS



FLANGE MOUNT (NFPA MF1 & MF2)

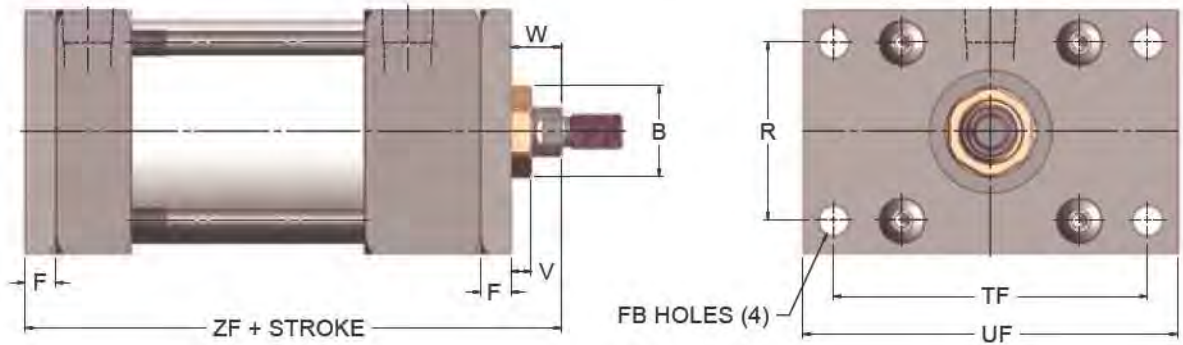

MODEL ST3F1

MODEL ST3F2



BORE	B	F	FB	R	TF	UF	V	W	ZF
1 1/2	1 1/8	3/8	5/16	1.43	2 3/4	3 3/8	1/4	5/8	5
2	1 1/8	3/8	3/8	1.84	3 3/8	4 1/8	1/4	5/8	5
2 1/2	1 1/8	3/8	3/8	2.19	3 7/8	4 5/8	1/4	5/8	5 1/8
3 1/4	1 1/2	5/8	7/16	2.76	4 11/16	5 1/2	1/4	3/4	6 1/4
4	1 1/2	5/8	7/16	3.32	5 7/16	6 1/4	1/4	3/4	6 1/4
5	1 1/2	5/8	9/16	4.10	6 5/8	7 5/8	1/4	3/4	6 1/2
6	2	3/4	9/16	4.88	7 5/8	8 5/8	1/4	7/8	7 3/8

TIE RODS EXTENDED MOUNT (NFPA MX1, MX2 & MX3)

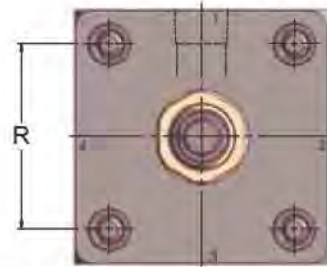
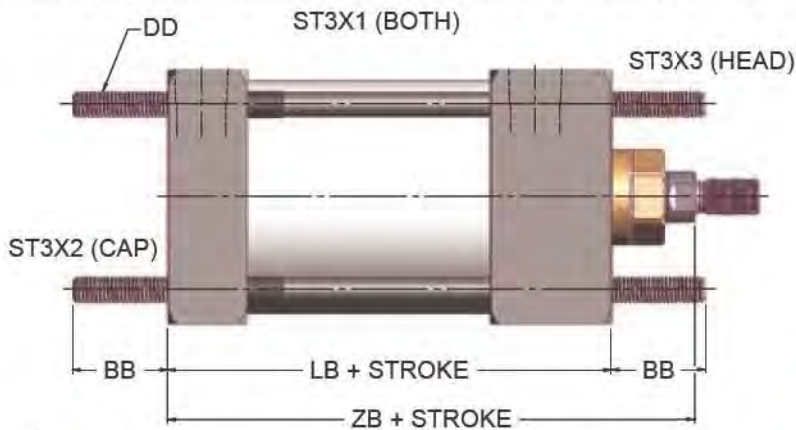

MODEL ST3X1

MODEL ST3X3

MODEL ST3X2

BORE	BB	DD	LB	R	ZB
1 1/2	1	1/4-28	3 5/8	1.43	4 5/8
2	1 1/8	5/16-24	3 5/8	1.84	4 5/8
2 1/2	1 1/8	5/16-24	3 3/4	2.19	4 3/4
3 1/4	1 3/8	3/8-24	4 1/4	2.76	5 5/8
4	1 3/8	3/8-24	4 1/4	3.32	5 5/8
5	1 13/16	1/2-20	4 1/2	4.12	5 7/8
6	1 13/16	1/2-20	5	4.88	6 5/8
7*	2 5/16	5/8-18	5 1/8	5.73	6 3/4
8*	2 5/16	5/8-18	5 1/8	6.44	6 3/4
10*	2 9/16	3/4-16	6 3/8	7.92	8 1/4
12*	2 9/16	3/4-16	6 7/8	9.41	8 7/8

*Only for 7,8,10,12" bore, Since they are not Flush Mount, Nuts will be use on the oposite of the "Tie Rods extended Mount" Or cap end for the "ST3X1 Mount"

STAR3 CYLINDERS

CLEVIS MOUNT (NFPA MP1, MP2 & MP4)



MODEL ST3P1

Pin and Snap ring Included

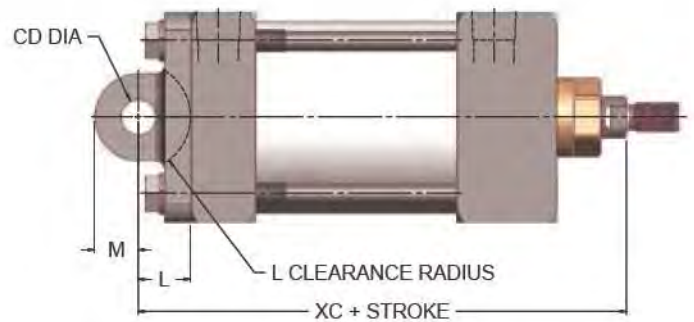
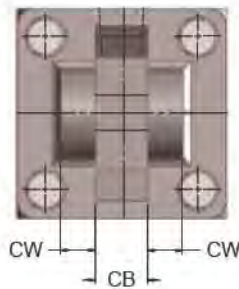

MODEL ST3P2

Pin and Snap ring Included

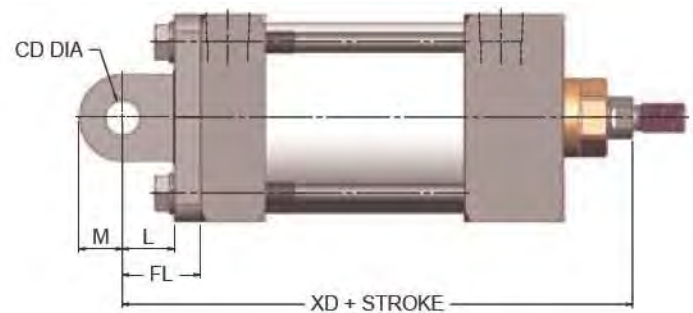
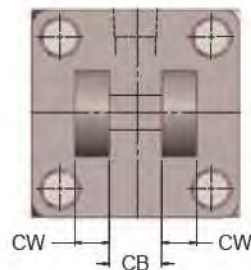

MODEL ST3P4

Pin and Snap ring NOT Included

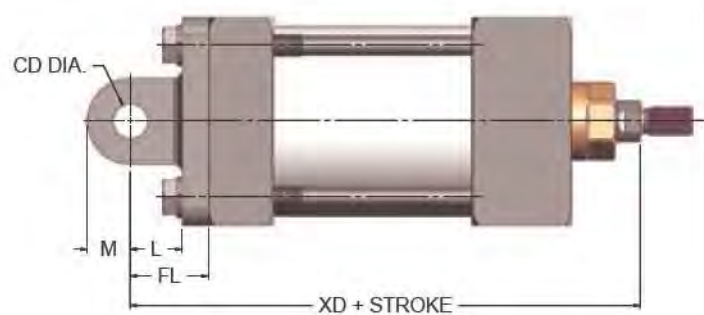
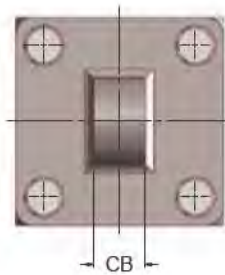

BORE	CB	CD	CW	FL	L	M	XC	XD
1 1/2	3/4	1/2	1/2	1 1/8	3/4	5/8	5 3/8	5 3/4
2	3/4	1/2	1/2	1 1/8	3/4	5/8	5 3/8	5 3/4
2 1/2	3/4	1/2	1/2	1 1/8	3/4	5/8	5 1/2	5 7/8
3 1/4	1 1/4	3/4	5/8	1 7/8	1 1/4	7/8	6 7/8	7 1/2
4	1 1/4	3/4	5/8	1 7/8	1 1/4	7/8	6 7/8	7 1/2
5	1 1/4	3/4	5/8	1 7/8	1 1/4	7/8	7 1/8	7 3/4
6	1 1/2	1	3/4	2 1/4	1 1/2	1 1/4	8 1/8	8 7/8
7	1 1/2	1	3/4	2 1/4	1 1/2	1	8 1/4	9
8	1 1/2	1	3/4	2 1/4	1 1/2	1	8 1/4	9
10	2	1 3/8	1	N/A	2 1/8	1 3/8	10 3/8	N/A
12	2 1/2	1 3/4	1 1/4	N/A	2 1/4	1 3/4	11 1/8	N/A

STAR3 CYLINDERS

TRUNNION MOUNT (NFPA MT1, MT2 & MT4)

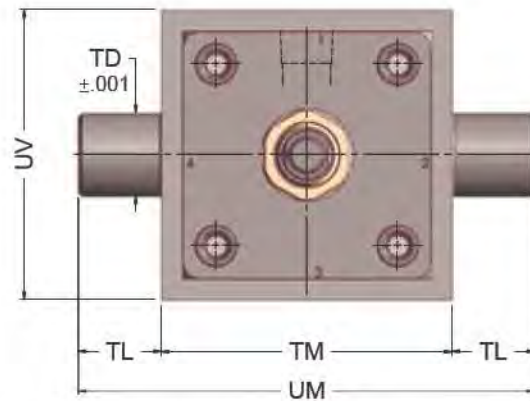
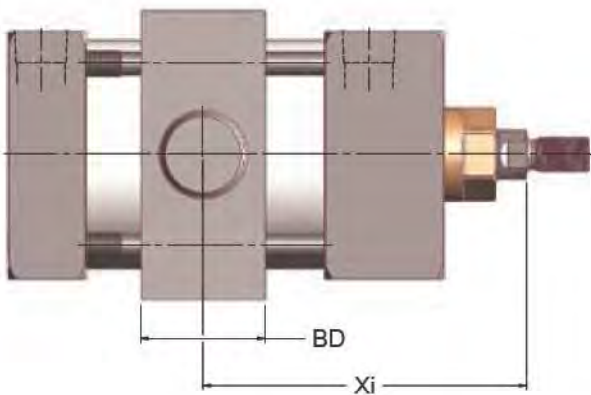
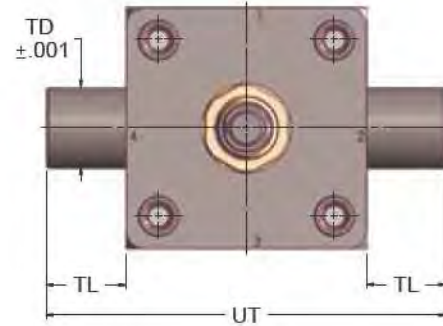
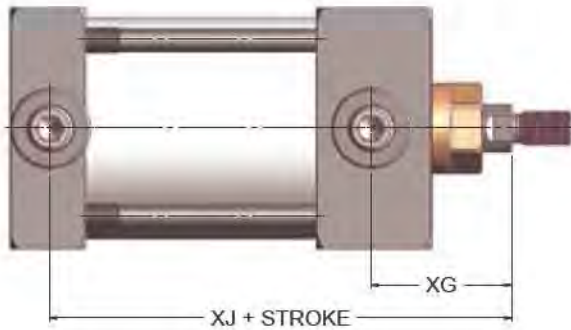

BORE	TD	TL	UT	ST3T1	ST3T2	ST3T4	UV	TM	UM	BD
				XG	XJ	Xi				
1 1/2	1	1	4	1 3/4	4 1/8	CUSTOMER MUST SPECIFY Xi	2 1/2	2 1/2	4 1/2	1 1/4
2	1	1	4 1/2	1 3/4	4 1/8		3	3	5	1 1/2
2 1/2	1	1	5	1 3/4	4 1/4		3 1/2	3 1/2	5 1/2	1 1/2
3 1/4	1	1	5 3/4	2 1/4	5		4 1/4	4 1/2	6 1/2	2
4	1	1	6 1/2	2 1/4	5		5	5 1/4	7 1/4	2
5	1	1	7 1/2	2 1/4	5 1/4		6	6 1/4	8 1/4	2
6	1 3/8	1 3/8	9 1/4	2 5/8	5 7/8		7	7 5/8	10 3/8	2 1/2
7	1 3/8	1 3/8	11 1/4	2 5/8	6		8 1/2	8 3/4	11 1/2	2 1/2
8	1 3/8	1 3/8	11 1/4	2 5/8	6		9 1/2	9 3/4	12 1/2	2 1/2



MODEL ST3T1



MODEL ST3T2



MODEL ST3T4

You can order the Trunnion in one piece steel for heavy duty applications. Use Suffix X
 Ex : ST3T1X-2.5X3 (Option only available for ST3T1 Or ST3T2)

STAR3 CYLINDERS



DETACHABLE SIDE LUG MOUNT (NFPA MS2)

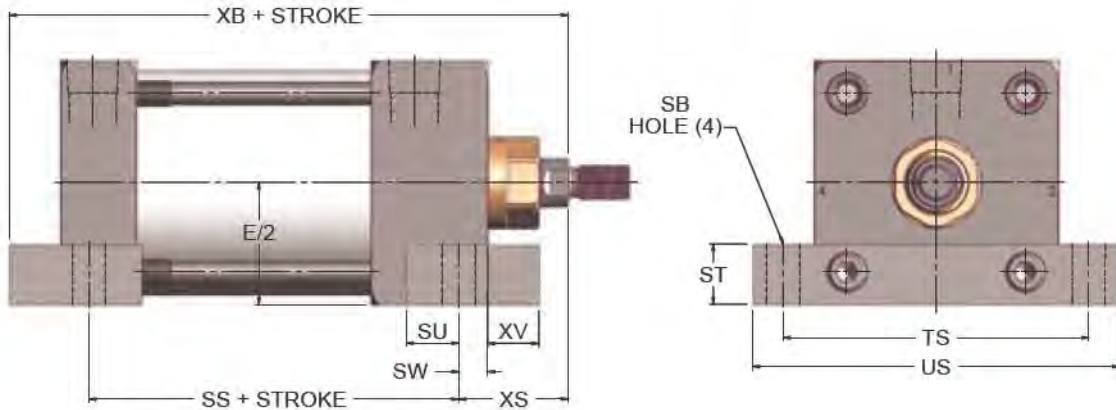

MODEL ST3S2

BORE	E	SB	SS	ST	SU	SW	TS	US	XB	XS	XV
1 1/2	2	13/32	2 7/8	9/16	5/8	3/8	2 3/4	3 1/2	5 1/8	1 3/8	1/2
2	2 1/2	13/32	2 7/8	5/8	5/8	3/8	3 1/4	4	5 1/4	1 3/8	5/8
2 1/2	3	13/32	3	3/4	5/8	3/8	3 3/4	4 1/2	5 3/8	1 3/8	5/8
3 1/4	3 3/4	17/32	3 1/4	1	3/4	1/2	4 3/4	5 3/4	6 3/8	1 7/8	3/4
4	4 1/2	17/32	3 1/4	1	3/4	1/2	5 1/2	6 1/2	6 3/8	1 7/8	3/4
5	5 1/2	25/32	3 1/8	1 1/4	9/16	11/16	6 7/8	8 1/4	6 13/16	2 1/16	15/16
6	6 1/2	25/32	3 5/8	1 1/2	7/8	11/16	7 7/8	9 1/4	7 9/16	2 5/16	15/16
7	7 1/2	25/32	3 3/4	1 3/4	7/8	11/16	9 7/8	11 1/4	7 13/16	2 5/16	15/16
8	8 1/2	25/32	3 3/4	1 3/4	7/8	11/16	9 7/8	11 1/4	7 13/16	2 5/16	15/16

FIXED SIDE LUG MOUNT (NFPA MS2E)

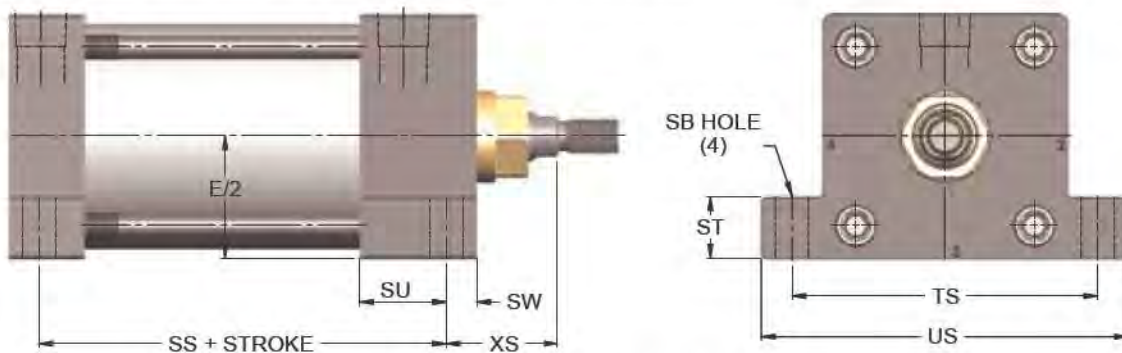

MODEL ST3S2E

BORE	SB	SS	ST	SU	SW	TS	US	XB	XS
1 1/2	13/32	2 7/8	9/16	5/8	3/8	2 3/4	3 1/2	5 1/8	1 3/8
2	13/32	2 7/8	5/8	5/8	3/8	3 1/4	4	5 1/4	1 3/8
2 1/2	13/32	3	3/4	5/8	3/8	3 3/4	4 1/2	5 3/8	1 3/8
3 1/4	17/32	3 1/4	1	3/4	1/2	4 3/4	5 3/4	6 3/8	1 7/8
4	17/32	3 1/4	1	3/4	1/2	5 1/2	6 1/2	6 3/8	1 7/8



SPECIAL MID SIDE LUG MOUNT
(ASK FACTORY)

STAR3 CYLINDERS



ANGLE MOUNT (NFPA MS1)

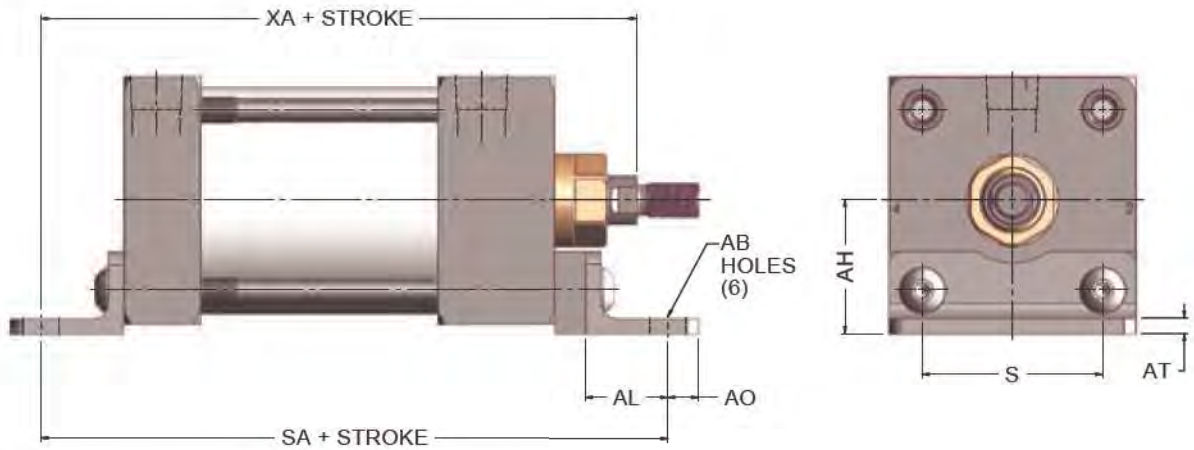

MODEL ST3S1

BORE	AB	AH	AL	AO	AT	S	SA	XA
1 1/2	7/16	1 3/16	1	3/8	1/8	1 1/4	6	5 5/8
2	7/16	1 7/16	1	3/8	1/8	1 3/4	6	5 5/8
2 1/2	7/16	1 5/8	1	3/8	1/8	2 1/4	6 1/8	5 3/4
3 1/4	9/16	1 15/16	1 1/4	1/2	3/16	2 3/4	7 3/8	6 7/8
4	9/16	2 1/4	1 1/4	1/2	3/16	3 1/2	7 3/8	6 7/8
5	11/16	2 3/4	1 3/8	1/2	3/16	4 1/4	7 7/8	7 1/4
6	11/16	3 1/4	1 3/8	5/8	1/4	5 1/4	8 1/2	8

AVAILABLE IN 7, 8, 10 & 12" BORE ASK FACTORY

END LUG MOUNT (NFPA MS7)

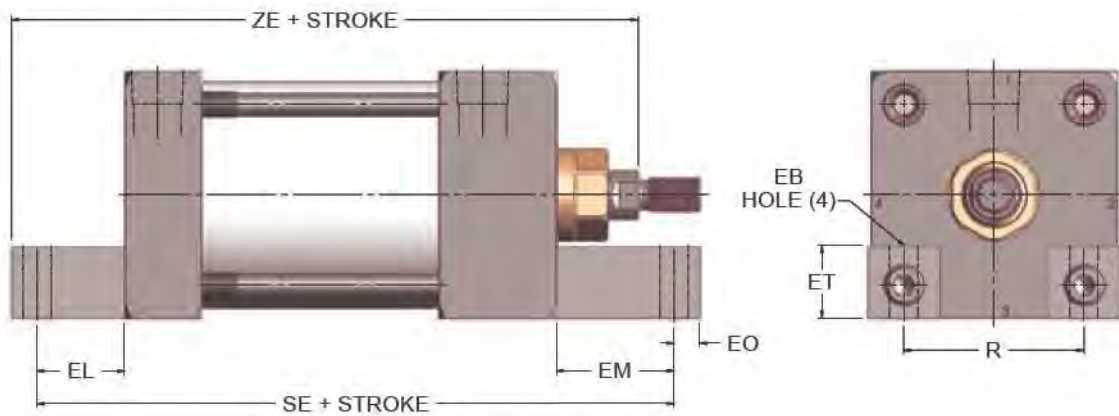

MODEL ST3S7

BORE	EB	EL	EM	EO	ET	SE	ZE	R
1 1/2	9/32	3/4	1 1/8	1/4	9/16	5 1/2	5 5/8	1.43
2	11/32	15/16	1 5/16	5/16	5/8	5 7/8	5 7/8	1.84
2 1/2	11/32	1 1/16	1 7/16	5/16	3/4	6 1/4	6 1/8	2.19
3 1/4	13/32	7/8	1 1/2	3/8	1	6 5/8	6 7/8	2.76
4	13/32	1	1 5/8	3/8	1 13/16	6 7/8	7	3.32
5	17/32	1 1/16	1 11/16	9/16	1 3/8	7 1/4	7 1/2	4.12
6	17/32	1	1 3/4	5/8	1 5/8	7 3/4	8 1/4	4.88
7	21/32	1 1/8	1 3/4	3/4	2	7 3/8	8 3/4	5.73
8	21/32	1 1/8	1 3/4	3/4	2	7 3/8	8 3/4	6.44

STAR3 CYLINDERS



SQUARE FLANGE HEAD MOUNT (NFPA ME3)

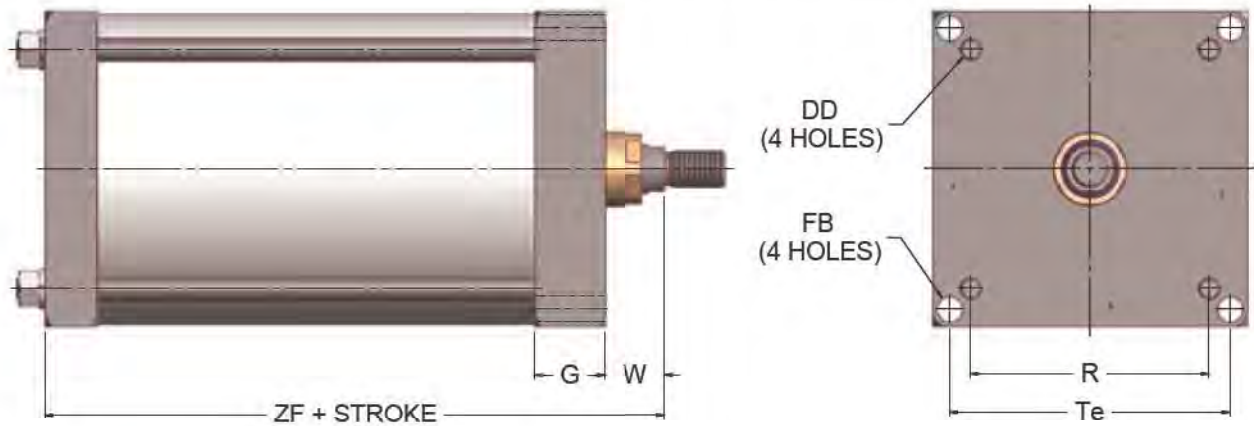

MODEL ST3E3

BORE	FB		G	R	DD	DD depth	Te	W	ZF
	(hole dia.)	For S.H.C.S.							
7	11/16	5/8	2	5.73	5/8-18	1	6.75	1 5/8	6 3/4
8	11/16	5/8	2	6.44	5/8-18	1	7.57	1 5/8	6 3/4
10	13/16	3/4	2 1/4	7.97	3/4-16	1 1/4	9.41	1 7/8	8 1/4
12	13/16	3/4	2 1/4	9.41	3/4-16	1 1/4	11.11	1 7/8	8 7/8

SQUARE FLANGE CAP MOUNT (NFPA ME4)

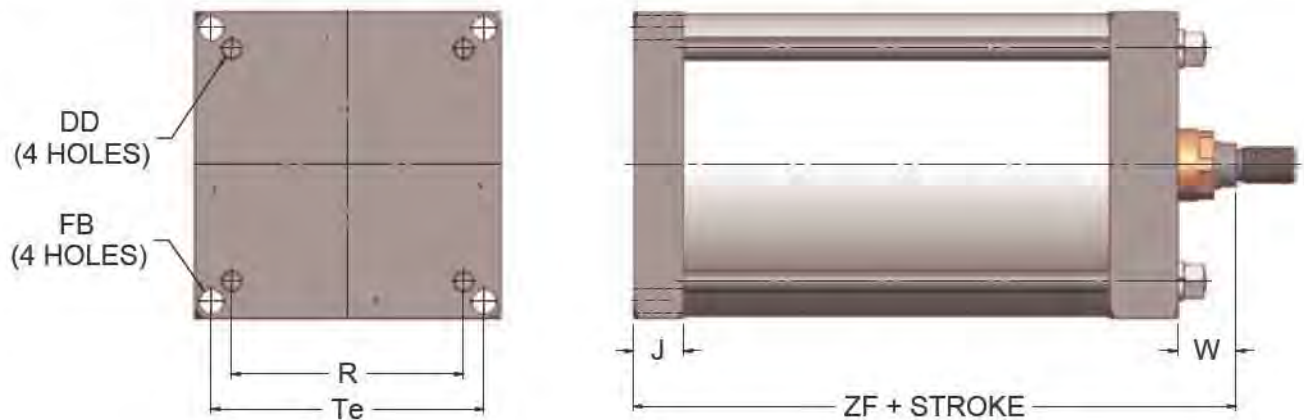

MODEL ST3E4

BORE	FB		J	R	DD	DD depth	Te	W	ZF
	(hole dia.)	For S.H.C.S.							
7	11/16	5/8	1 1/2	5.73	5/8-18	1	6.75	1 5/8	6 3/4
8	11/16	5/8	1 1/2	6.44	5/8-18	1	7.57	1 5/8	6 3/4
10	13/16	3/4	2	7.97	3/4-16	1 1/4	9.41	1 7/8	8 1/4
12	13/16	3/4	2	9.41	3/4-16	1 1/4	11.11	1 7/8	8 7/8

STAR30 CYLINDERS - Oversize Rod Diameters

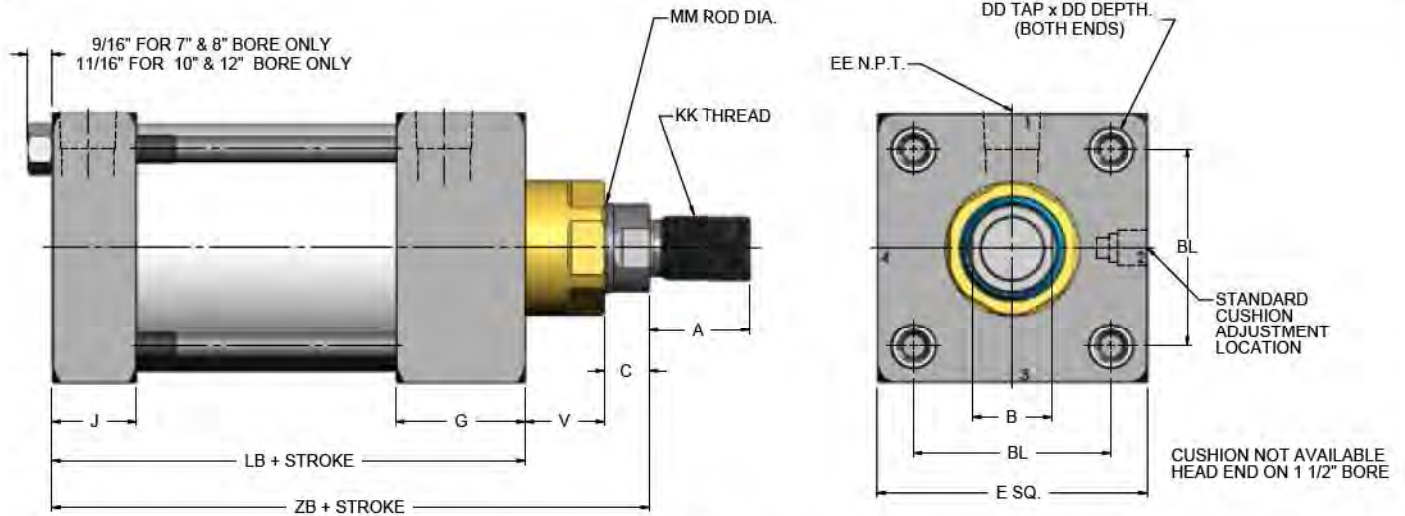

BORE	A	B	BL	C	DD	DDdepth*	E	EE	G	J	KK	LB	MM	V	ZB
1.5	1 1/8	1.498	1.43	1/2	1/4-28	0.50	2	3/8	1 1/2	1	3/4-16	3 5/8	1	7/8	5
2.0	1 1/8	1.498	1.84	1/2	5/16-24	0.50	2 1/2	3/8	1 1/2	1	3/4-16	3 5/8	1	7/8	5
2.5	1 1/8	1.498	2.19	1/2	5/16-24	0.50	3	3/8	1 1/2	1	3/4-16	3 3/4	1	7/8	5 1/8
3.25	1 5/8	1.998	2.76	5/8	3/8-24	0.63	3 3/4	1/2	1 3/4	1 1/4	1-14	4 1/4	1 3/8	1	5 7/8
4.0	1 5/8	1.998	3.32	5/8	3/8-24	0.63	4 1/2	1/2	1 3/4	1 1/4	1-14	4 1/4	1 3/8	1	5 7/8
5.0	1 5/8	1.998	4.12	5/8	1/2-20	0.75	5 1/2	1/2	1 3/4	1 1/4	1-14	4 1/2	1 3/8	1	6 1/8
6.0	2	2.373	4.88	3/4	1/2-20	0.75	6 1/2	3/4	2	1 1/2	1 1/4-12	5	1 3/4	1 1/8	6 7/8
7.0	2	2.373	5.73	3/4	5/8-18	0.75	7 1/2	3/4	2	1 1/2	1 1/4-12	5 1/8	1 3/4	1 1/8	7
8.0	2	2.373	6.44	3/4	5/8-18	0.75	8 1/2	3/4	2	1 1/2	1 1/4-12	5 1/8	1 3/4	1 1/8	7
10.00	2 1/4	2.623	7.92	7/8	3/4-18	1.00	10 5/8	1	2 1/4	2	1 1/2-12	6 3/8	2	1 1/8	8 3/8
12.00	3	3.123	9.41	1	3/4-16	1.00	12 3/4	1	2 1/4	2	1 7/8-12	6 7/8	2 1/2	1 1/4	9 1/8

*Can be use for front or rear Mount direct with the face of the cylinder

ROD END STYLE

FULL MALE #1F

MM ROD

FF THD

MM ROD

KK THD

WRENCH FLATS

SMALL MALE #2S STUDDED

MM ROD

KK THD

LARGE MALE #1

MM ROD

KK THD

FEMALE #4

MM ROD

KK THD A DEEP

SMALL MALE #2*

* FOR 1" ROD, THE ROD END WILL BE STUDDED #2S STANDARD

ROD DIA.	A	C	D	V	CC	FF	KK
1	1 1/8	1/2	7/8	7/8	7/8-14	1-14	3/4-16
1 3/8	1 5/8	5/8	1 3/16	1	1 1/4-12	1 3/8-12	1-14
1 3/4	2	3/4	1 1/2	1 1/8	1 1/2-12	1 3/4-12	1 1/4-12
2	2 3/8	7/8	1 3/4	1 1/8	1 3/4-12	2-12	1 1/2-12
2 1/2	3	1	2 1/16	1 1/4	2 1/4-12	2 1/2-12	1 7/8-12

STAR30 CYLINDERS - Ovesize Rod



DOUBLE ROD END (ST30D)

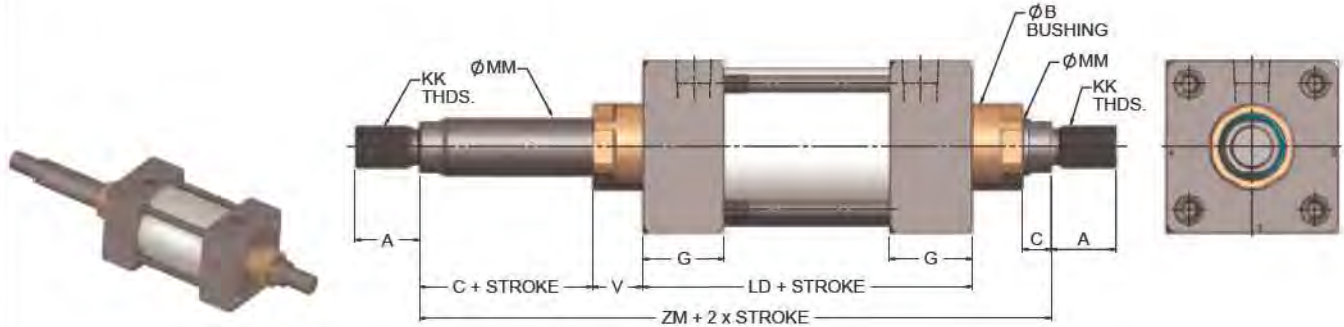

BORE	A	B	C	E	G	R	V	EE	LD	KK	MM	ZM
1 1/2	1 1/8	1.498	1/2	2	1 1/2	1.43	7/8	3/8	4 1/8	3/4-16	1	6 7/8
2	1 1/8	1.498	1/2	2 1/2	1 1/2	1.84	7/8	3/8	4 1/8	3/4-16	1	6 7/8
2 1/2	1 1/8	1.498	1/2	3	1 1/2	2.19	7/8	3/8	4 1/4	3/4-16	1	7
3 1/4	1 5/8	1.998	5/8	3 3/4	1 3/4	2.78	1	1/2	4 3/4	1-14	1 3/8	8
4	1 5/8	1.998	5/8	4 1/2	1 3/4	3.32	1	1/2	4 3/4	1-14	1 3/8	8
5	1 5/8	1.998	5/8	5 1/2	1 3/4	4.12	1	1/2	5	1-14	1 3/8	8
6	1 3/4	2.373	3/4	6 1/2	2	4.88	1 1/8	3/4	5 1/2	1 1/4-12	1 3/4	9 1/4
7	1 3/4	2.373	3/4	7 1/2	2	5.73	1 1/8	3/4	5 5/8	1 1/4-12	1 3/4	9 3/8
8	1 3/4	2.373	3/4	8 1/2	2	6.44	1 1/8	3/4	5 5/8	1 1/4-12	1 3/4	9 3/8
10	2	2.623	7/8	10 5/8	2 1/4	7.92	1 1/8	1	6 5/8	1 1/2-12	2	10 5/8
12	2 1/2	3.123	1	12 3/4	2 1/4	9.41	1 1/4	1	7 1/8	1 7/8-12	2 1/2	11 5/8

BOTTOM TAP MOUNT (NFPA MS4)

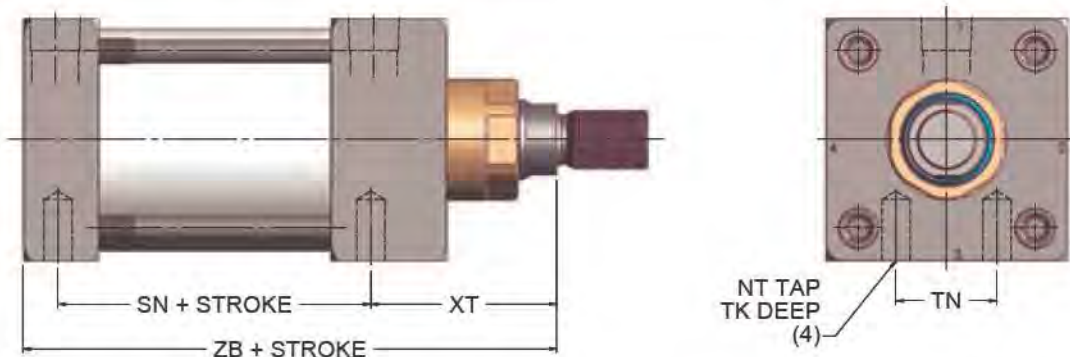

MODEL ST30S4



BORE	NT	TK	TN	SN	XT	ZB
1 1/2	1/4-20	3/8	5/8	2 1/4	1 15/16	5
2	5/16-18	1/2	7/8	2 1/4	1 15/16	5
2 1/2	3/8-16	5/8	1 1/4	2 3/8	1 15/16	5 1/8
3 1/4	1/2-13	3/4	1 1/2	2 5/8	2 7/16	5 7/8
4	1/2-13	3/4	2 1/16	2 5/8	2 7/16	5 7/8
5	5/8-11	1	2 11/16	2 7/8	2 7/16	6 1/8
6	3/4-10	1 1/8	3 1/4	3 1/8	2 13/16	6 7/8
7	3/4-10	1 1/8	3 1/2	3 1/4	2 13/16	7
8	3/4-10	1 1/8	4 1/2	3 1/4	2 13/16	7
10	1-8	1 1/2	5 1/2	4 1/8	3 1/8	8 7/8
12	1-8	1 1/2	7 1/4	4 5/8	3 1/4	9 1/8

STAR30 CYLINDERS - Ovesize Rod



FLANGE MOUNT (NFPA MF1 & MF2)

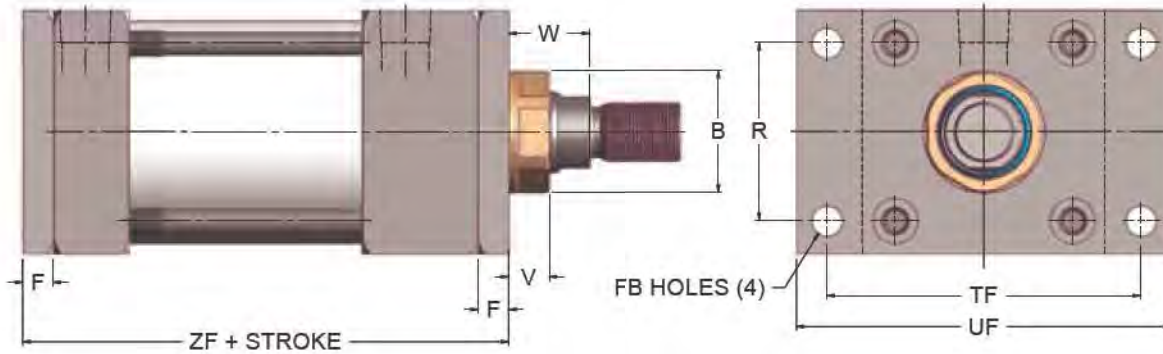

MODEL ST3OF1

MODEL ST3OF2



BORE	B	F	FB	R	TF	UF	V	W	ZF
1 1/2	1 1/2	3/8	5/16	1.43	2 3/4	3 3/8	1/2	1	5 3/8
2	1 1/2	3/8	3/8	1.84	3 3/8	4 1/8	1/2	1	5 3/8
2 1/2	1 1/2	3/8	3/8	2.19	3 7/8	4 1/8	1/2	1	5 1/2
3 1/4	2	5/8	7/16	2.76	4 11/16	5 1/2	3/8	1	6 1/2
4	2	5/8	7/16	3.32	5 7/16	6 1/4	3/8	1	6 1/2
5	2	5/8	9/16	4.10	6 5/8	7 5/8	3/8	1	6 3/4
6	2 3/8	3/4	9/16	4.88	7 5/8	8 5/8	3/8	1 1/8	7 5/8

TIE RODS EXTENDED MOUNT (NFPA MX1, MX2 & MX3)

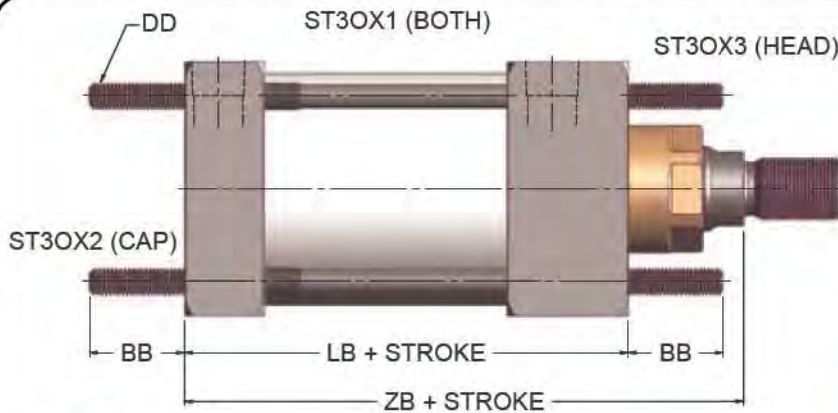

BORE	BB	DD	LB	R	ZB
1 1/2	1	1/4-28	3 5/8	1.43	5
2	1 1/8	5/16-24	3 5/8	1.84	5
2 1/2	1 1/8	5/16-24	3 3/4	2.19	5 1/8
3 1/4	1 3/8	3/8-24	4 1/4	2.76	5 7/8
4	1 3/8	3/8-24	4 1/4	3.32	5 7/8
5	1 13/16	1/2-20	4 1/2	4.12	6 1/8
6	1 13/16	1/2-20	5	4.88	6 7/8
7*	2 5/16	5/8-18	5 1/8	5.73	7
8*	2 5/16	5/8-18	5 1/8	6.44	7
10*	2 9/16	3/4-16	6 3/8	7.92	8 3/8
12*	2 9/16	3/4-16	6 7/8	9.41	9 1/8

*Only for 7,8,10,12" bore, Since they are not Flush Mount, Nuts will use on the opposite of the "Tie Rods extended Mount" Or cap end for the "ST3X1 Mount"

STAR30 CYLINDERS - Ovesize Rod



CLEVIS MOUNT (NFPA MP1, MP2 & MP4)



MODEL ST3OP1

Pin and Snap ring Included

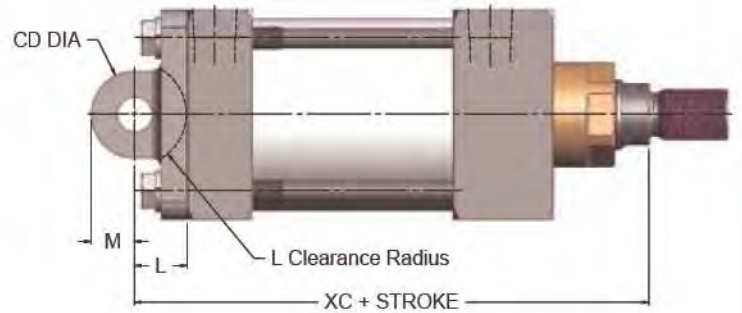
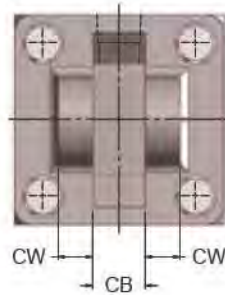

MODEL ST3OP2

Pin and Snap ring Included

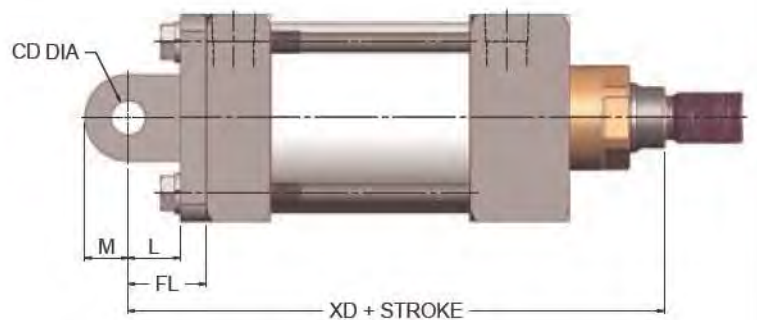
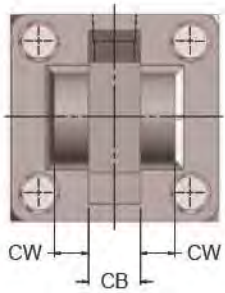

MODEL ST3OP4

Pin and Snap ring NOT Included

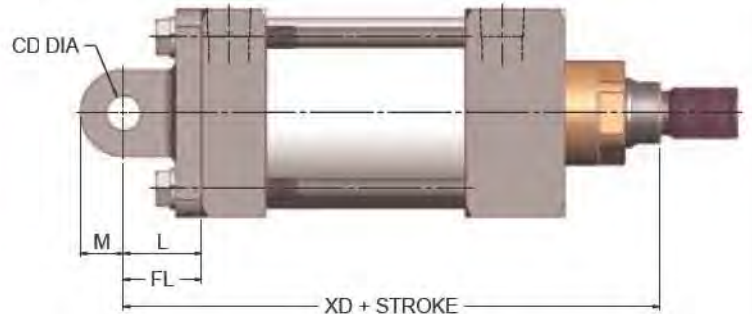
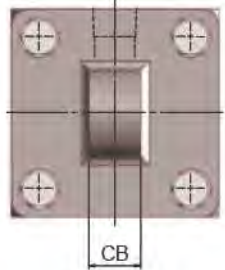

BORE	CB	CD	CW	FL	L	M	XC	XD
1 1/2	3/4	1/2	1/2	1 1/8	3/4	5/8	5 3/4	6 1/8
2	3/4	1/2	1/2	1 1/8	3/4	5/8	5 3/4	6 1/8
2 1/2	3/4	1/2	1/2	1 1/8	3/4	5/8	5 7/8	6 1/4
3 1/4	1 1/4	3/4	5/8	1 7/8	1 1/4	7/8	7 1/8	7 3/4
4	1 1/4	3/4	5/8	1 7/8	1 1/4	7/8	7 1/8	7 3/4
5	1 1/4	3/4	5/8	1 7/8	1 1/4	7/8	7 3/8	8
6	1 1/2	1	3/4	2 1/4	1 1/2	1 1/4	8 3/8	9 1/8
7	1 1/2	1	3/4	2 1/4	1 1/2	1	8 1/2	9 1/4
8	1 1/2	1	3/4	2 1/4	1 1/2	1	8 1/2	9 1/4
10	2	1 3/8	1	N/A	2 1/8	1 3/8	10 1/2	N/A
12	2 1/2	1 3/4	1 1/4	N/A	2 1/4	1 3/4	11 1/2	N/A

STAR30 CYLINDERS - Oversize Rod



TRUNNION MOUNT (NFPA MT1, MT2 & MT4)

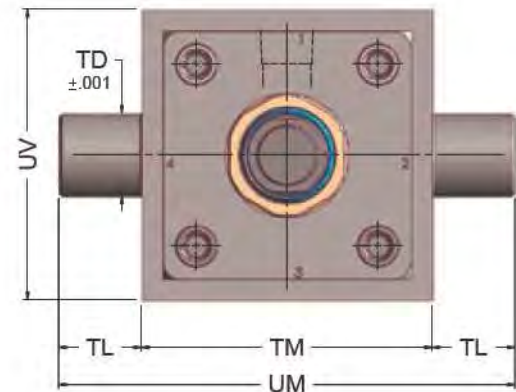
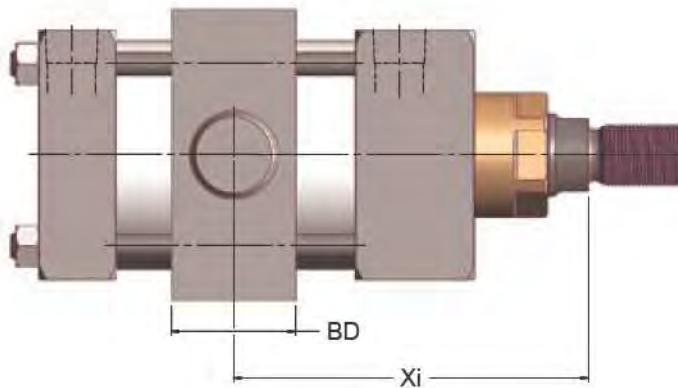
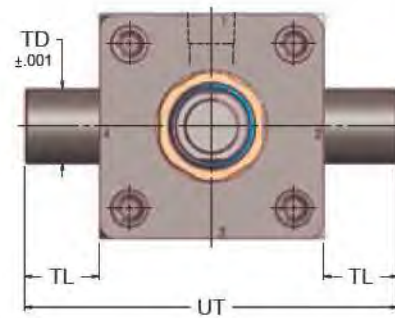
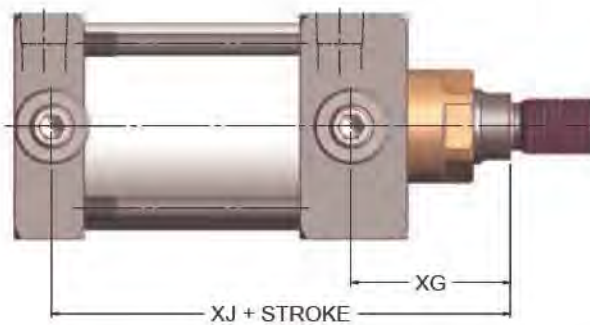

BORE	TD	TL	UT	ST3T1	ST3T2	ST3T4	UV	TM	UM	BD
				XG	XJ	Xi				
1 1/2	1	1	4	N/A*	4 1/2	CUSTOMER MUST SPECIFY Xi	2 1/2	2 1/2	4 1/2	1 1/4
2	1	1	4 1/2	2 1/8	4 1/2		3	3	5	1 1/2
2 1/2	1	1	5	2 1/8	4 5/8		3 1/2	3 1/2	5 1/2	1 1/2
3 1/4	1	1	5 3/4	2 1/2	5 1/4		4 1/4	4 1/2	6 1/2	2
4	1	1	6 1/2	2 1/2	5 1/4		5	5 1/4	7 1/4	2
5	1	1	7 1/2	2 1/2	5 1/2		6	6 1/4	8 1/4	2
6	1 3/8	1 3/8	9 1/4	2 7/8	6 1/8		7	7 5/8	10 3/8	2 1/2
7	1 3/8	1 3/8	11 1/4	2 7/8	6 1/4		8 1/2	8 3/4	11 1/2	2 1/2
8	1 3/8	1 3/8	11 1/4	2 7/8	6 1/4		9 1/2	9 3/4	12 1/2	2 1/2



MODEL ST3OT1



MODEL ST3OT2



MODEL ST3OT4

You can order the Trunnion in one piece steel for heavy duty applications. Use Suffix X
 Ex : ST3OT1X-2.5X3 (Option only available for ST3OT1 Or ST3OT2)

*Not available in Aluminum Construction, available in one piece steel. (see note above)

STAR30 CYLINDERS - Ovesize Rod



DETACHABLE SIDE LUG MOUNT (NFPA MS2)

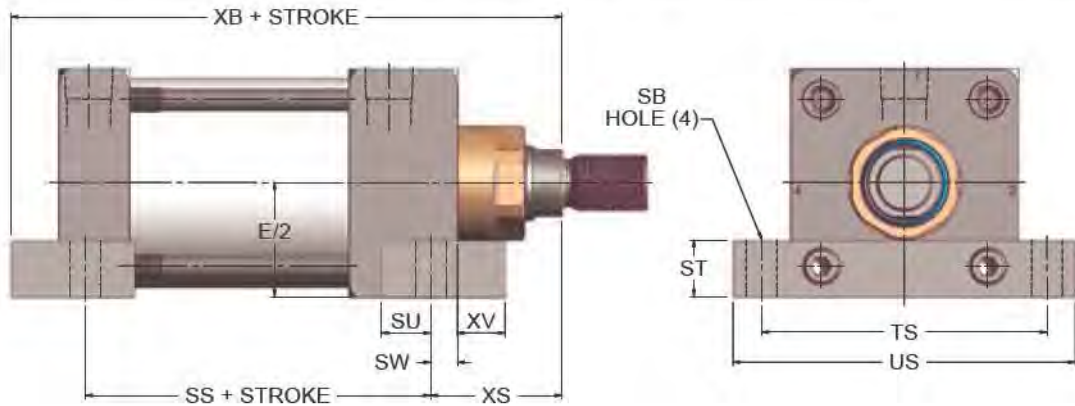

MODEL ST3OS2

BORE	E	SB	SS	ST	SU	SW	TS	US	XB	XS	XV
1 1/2	2	13/32	2 7/8	9/16	5/8	3/8	2 3/4	3 1/2	5 1/2	1 3/4	1/2
2	2 1/2	13/32	2 7/8	5/8	5/8	3/8	3 1/4	4	5 5/8	1 3/4	5/8
2 1/2	3	13/32	3	3/4	5/8	3/8	3 3/4	4 1/2	5 3/4	1 3/4	5/8
3 1/4	3 3/4	17/32	3 1/4	1	3/4	1/2	4 3/4	5 3/4	6 5/8	2 1/8	3/4
4	4 1/2	17/32	3 1/4	1	3/4	1/2	5 1/2	6 1/2	6 5/8	2 1/8	3/4
5	5 1/2	25/32	3 1/8	1 1/4	9/16	11/16	6 7/8	8 1/4	7 1/16	2 5/16	15/16
6	6 1/2	25/32	3 5/8	1 1/2	7/8	11/16	7 7/8	9 1/4	7 13/16	2 9/16	15/16
7	7 1/2	25/32	3 3/4	1 3/4	7/8	11/16	9 7/8	11 1/4	8 1/16	2 9/16	15/16
8	8 1/2	25/32	3 3/4	1 3/4	7/8	11/16	9 7/8	11 1/4	8 1/16	2 9/16	15/16

FIXED SIDE LUG MOUNT (NFPA MS2E)

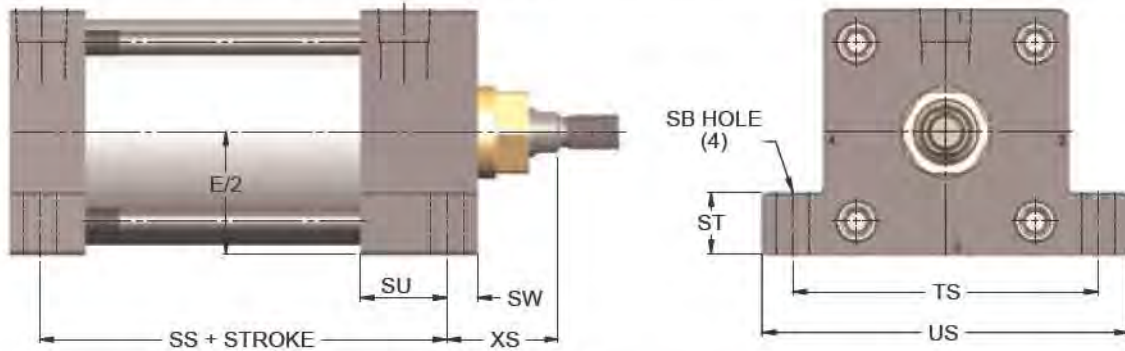

MODEL ST3OS2E

BORE	SB	SS	ST	SU	SW	TS	US	XB	XS
1 1/2	13/32	2 7/8	9/16	5/8	3/8	2 3/4	3 1/2	5 1/2	1 3/4
2	13/32	2 7/8	5/8	5/8	3/8	3 1/4	4	5 5/8	1 3/4
2 1/2	13/32	3	3/4	5/8	3/8	3 3/4	4 1/2	5 3/4	1 3/4
3 1/4	17/32	3 1/4	1	3/4	1/2	4 3/4	5 3/4	6 5/8	2 1/8
4	17/32	3 1/4	1	3/4	1/2	5 1/2	6 1/2	6 5/8	2 1/8



SPECIAL MID SIDE LUG MOUNT
(ASK FACTORY)

STAR30 CYLINDERS - Oversize Rod



ANGLE MOUNT (NFPA MS1)

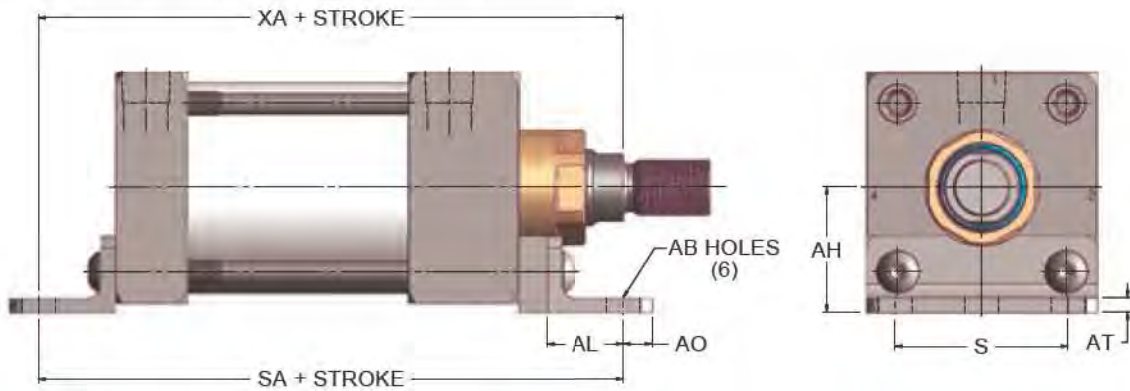

MODEL ST3OS1

BORE	AB	AH	AL	AO	AT	S	SA	XA
1 1/2	7/16	13/16	1	3/8	1/8	1 1/4	6	6
2	7/16	17/16	1	3/8	1/8	1 3/4	6	6
2 1/2	7/16	1 5/8	1	3/8	1/8	2 1/4	6 1/8	6 1/8
3 1/4	9/16	1 15/16	1 1/4	1/2	3/16	2 3/4	7 3/8	7 1/8
4	9/16	2 1/4	1 1/4	1/2	3/16	3 1/2	7 3/8	7 1/8
5	11/16	2 3/4	1 3/8	1/2	3/16	4 1/4	7 7/8	7 1/2
6	11/16	3 1/4	1 3/8	5/8	1/4	5 1/4	8 1/2	8 1/4

AVAILABLE IN 7, 8, 10 & 12" BORE ASK FACTORY

END LUG MOUNT (NFPA MS7)

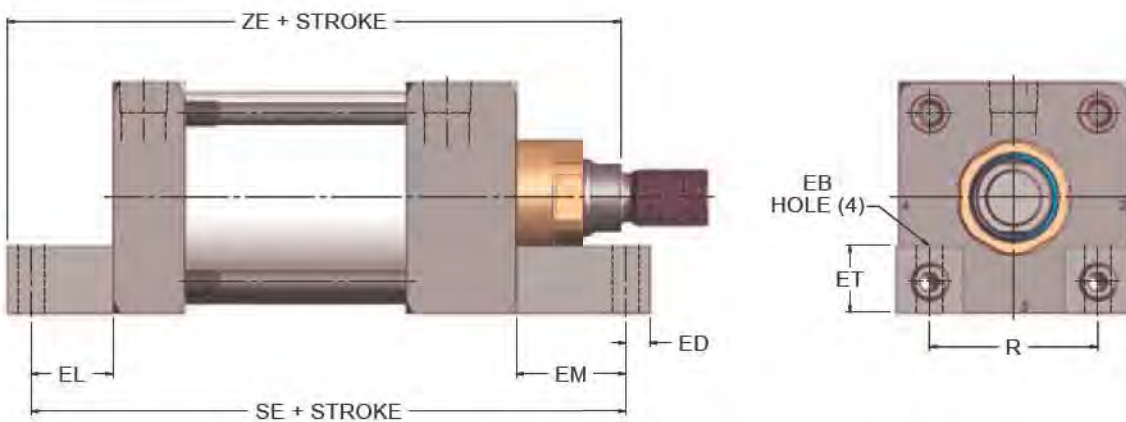

MODEL ST3OS7

BORE	EB	EL	EM	EO	ET	SE	ZE	R
1 1/2	NOT AVAILABLE IN OVERSIZE ROD							
2	11/32	15/16	1 5/16	5/16	5/8	5 7/8	6 1/4	1.84
2 1/2	11/32	1 1/16	1 7/16	5/16	3/4	6 1/4	6 1/2	2.19
3 1/4	13/32	7/8	1 1/2	3/8	1	6 5/8	7 1/8	2.76
4	13/32	1	1 5/8	3/8	1 13/16	6 7/8	7 1/4	3.32
5	17/32	1 1/16	1 11/16	9/16	1 3/8	7 1/4	7 1/2	4.12
6	17/32	1	1 3/4	5/8	1 5/8	7 3/4	8 1/4	4.88
7	21/32	1 1/8	1 3/4	3/4	2	7 3/8	8 3/4	5.73
8	21/32	1 1/8	1 3/4	3/4	2	7 3/8	8 3/4	6.44

STAR30 CYLINDERS - Oversize Rod



SQUARE FLANGE HEAD MOUNT (NFPA ME3)

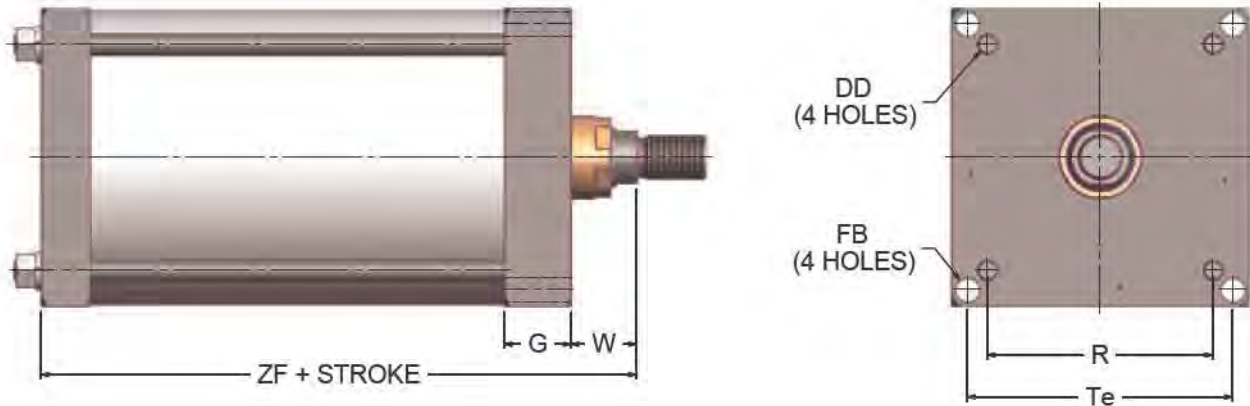

MODEL ST30E3

BORE	FB		G	R	DD	DD depth	Te	W	ZF
	(hole dia.)	For S.H.C.S.							
7	11/16	5/8	2	5.73	5/8-18	1	6.75	1 5/8	7
8	11/16	5/8	2	6.44	5/8-18	1	7.57	1 5/8	7
10	13/16	3/4	2 1/4	7.97	3/4-16	1 1/4	9.41	1 7/8	8 3/8
12	13/16	3/4	2 1/4	9.41	3/4-16	1 1/4	11.11	1 7/8	

SQUARE CAP FLANGE MOUNT (NFPA ME4)

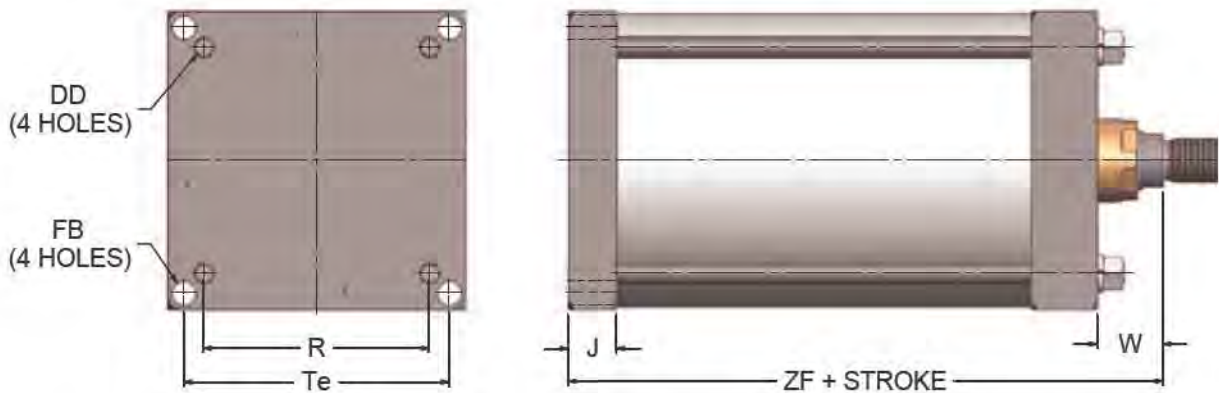

MODEL ST30E4

BORE	FB		J	R	DD	DD depth	Te	W	ZF
	(hole dia.)	For S.H.C.S.							
7	11/16	5/8	1 1/2	5.73	5/8-18	1	6.75	1 5/8	7
8	11/16	5/8	1 1/2	6.44	5/8-18	1	7.57	1 5/8	7
10	13/16	3/4	2	7.97	3/4-16	1 1/4	9.41	1 7/8	8 3/8
12	13/16	3/4	2	9.41	3/4-16	1 1/4	11.11	1 7/8	

STAR3 CYLINDERS

BACK-TO-BACK (ST3BB)

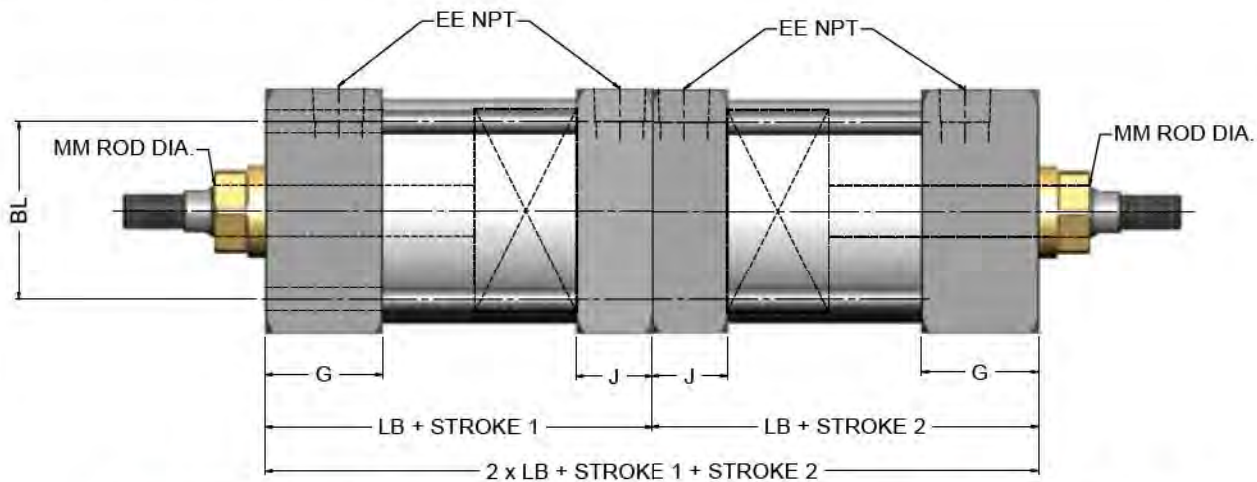

MODEL	BORE	MM	E	EE	G	J	LB	BL
ST3BB & ST3OBB	1 1/2	5/8 & 1"	2	3/8	1 1/2	1	3 5/8	1.430
	2	5/8 & 1"	2 1/2	3/8	1 1/2	1	3 5/8	1.840
	2 1/2	5/8 & 1"	3	3/8	1 1/2	1	3 3/4	2.190
	3 1/4	1 & 1 3/8"	3 3/4	1/2	1 3/4	1 1/4	4 1/4	2.760
	4	1 & 1 3/8"	4 1/2	1/2	1 3/4	1 1/4	4 1/4	3.320
	5	1 & 1 3/8"	5 1/2	1/2	1 3/4	1 1/4	4 1/2	4.120
	6	1 3/8 & 1 3/4"	6 1/2	3/4	2	1 1/2	5	4.880

Also available in 7", 8", 10 & 12" bore

This Model is two cylinders mounted back to back. Each cylinder can be operated independently. The cylinders can have the same stroke or different strokes. This configuration enables you to have four positions of rods extended or retracted. Unlike a three-position cylinder (Multi position page 23), a back-to-back cylinder provides "Hard" stop positioning.



MODEL ST3BB or
ST3OBB

STAR3 CYLINDERS

MULTI POSITION (ST3MP)

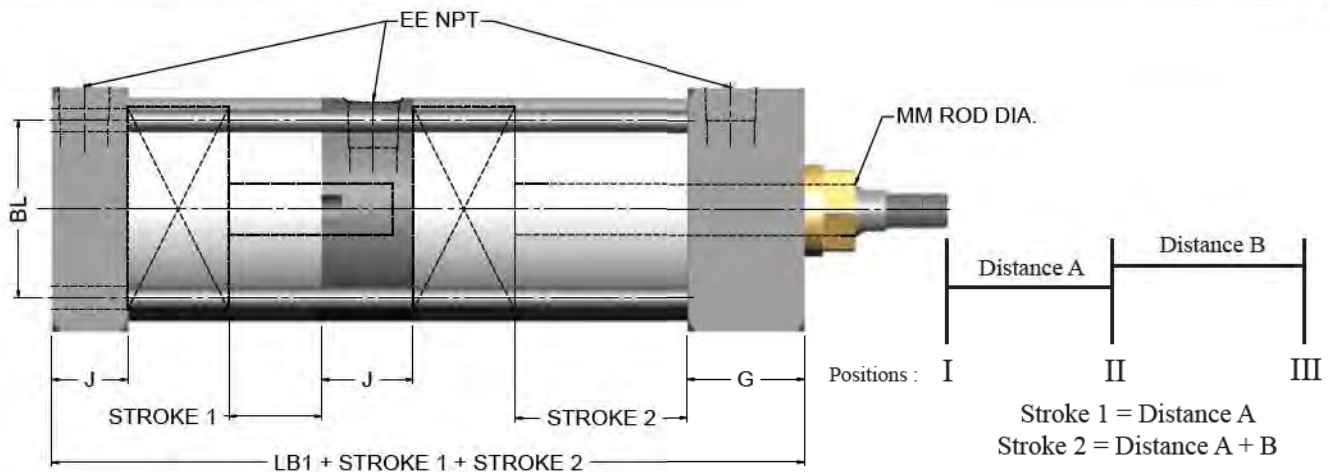

MODEL	BORE	MM	E	EE	G	J	LB1	BL
ST3MP & ST3OMP	1 1/2	5/8 & 1"	2	3/8	1 1/2	1	5 3/4	1.430
	2	5/8 & 1"	2 1/2	3/8	1 1/2	1	5 3/4	1.840
	2 1/2	5/8 & 1"	3	3/8	1 1/2	1	6	2.190
	3 1/4	1 & 1 3/8"	3 3/4	1/2	1 3/4	1 1/4	6 3/4	2.760
	4	1 & 1 3/8"	4 1/2	1/2	1 3/4	1 1/4	6 3/4	3.320
	5	1 & 1 3/8"	5 1/2	1/2	1 3/4	1 1/4	7 1/4	4.120
	6	1 3/8 & 1 3/4"	6 1/2	3/4	2	1 1/2	8	4.880

This model consists of multiple cylinders built as one unit having only one exposed working rod end, capable of delivering at least 3 positions. (Piston rod not attached) Three-Position cylinders rely on the back of the piston rod to push against the front piston rod to create the intermediate position, Care must be used to prevent the front piston rod from extending in the intermediate position.

Position I : Pressure to port "A" fully retracts cylinder

Position II : Pressure to port "D" advances cylinder to mid-stroke positions

Position III : Pressure to port "C" fully extends cylinder.

B : Breather/Vent

How to make the part number :

Application calls for a 1.5" bore with stroke position of 0", 2" and 4", with front flange mount.

The part number will be : ST3MPF1-1.5x2&4-#2

Also available in 7", 8", 10 & 12" bore

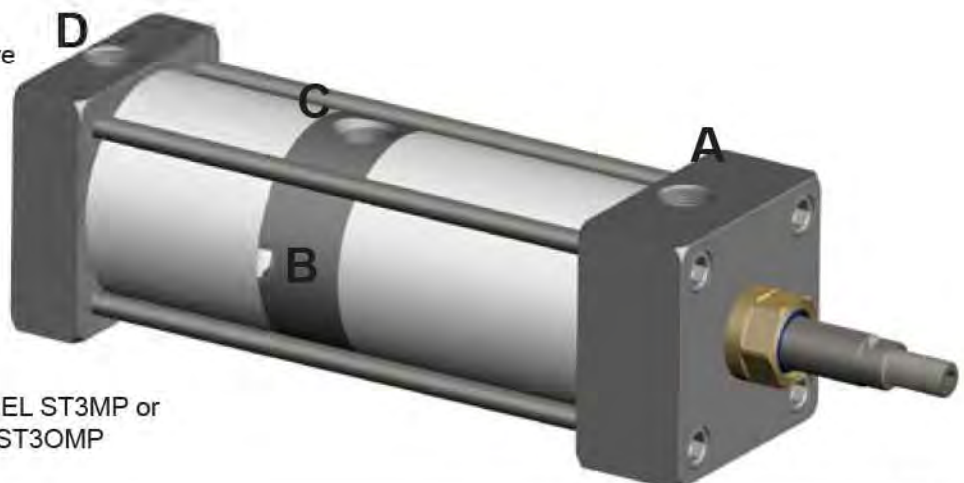

MODEL ST3MP or
ST3OMP

STAR3 CYLINDERS

TANDEM CYLINDER (ST3TD)

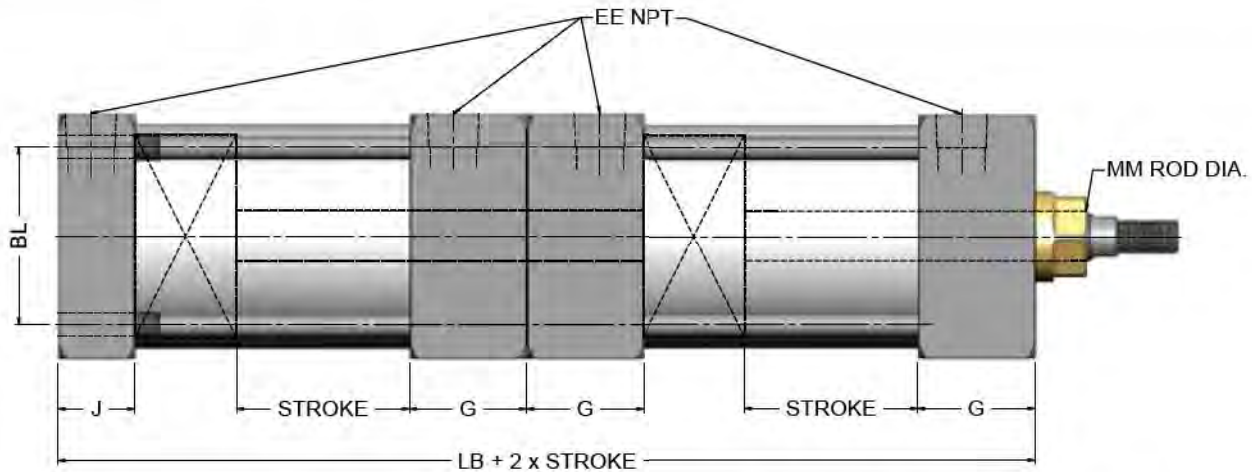

MODEL	BORE	MM	E	EE	G	J	LB	BL
ST3TD & ST3OTD	1 1/2	5/8 & 1"	2	3/8	1 1/2	1	3 5/8	1.430
	2	5/8 & 1"	2 1/2	3/8	1 1/2	1	3 5/8	1.840
	2 1/2	5/8 & 1"	3	3/8	1 1/2	1	3 3/4	2.190
	3 1/4	1 & 1 3/8"	3 3/4	1/2	1 3/4	1 1/4	4 1/4	2.760
	4	1 & 1 3/8"	4 1/2	1/2	1 3/4	1 1/4	4 1/4	3.320
	5	1 & 1 3/8"	5 1/2	1/2	1 3/4	1 1/4	4 1/2	4.120
	6	1 3/8 & 1 3/4"	6 1/2	3/4	2	1 1/2	5	4.880

Also available in 7", 8", 10 & 12" bore

The Air over Oil design is the most use of tandem cylinders today. You can use any combination of mounts available. Air provides the force to extend and retract the cylinder in the first part while the second part filled with oil provides the precise control of the stroke. By metering the flow of the hydraulic side of the cylinder, a constant velocity is achieved throughout the stroke, even at very slow speed that air cylinder typically chatter.



MODEL ST3TD or
ST3OTD

STAR3 CYLINDERS - Air/Oil Tank

AIR/OIL TANK (ST3TKS1)

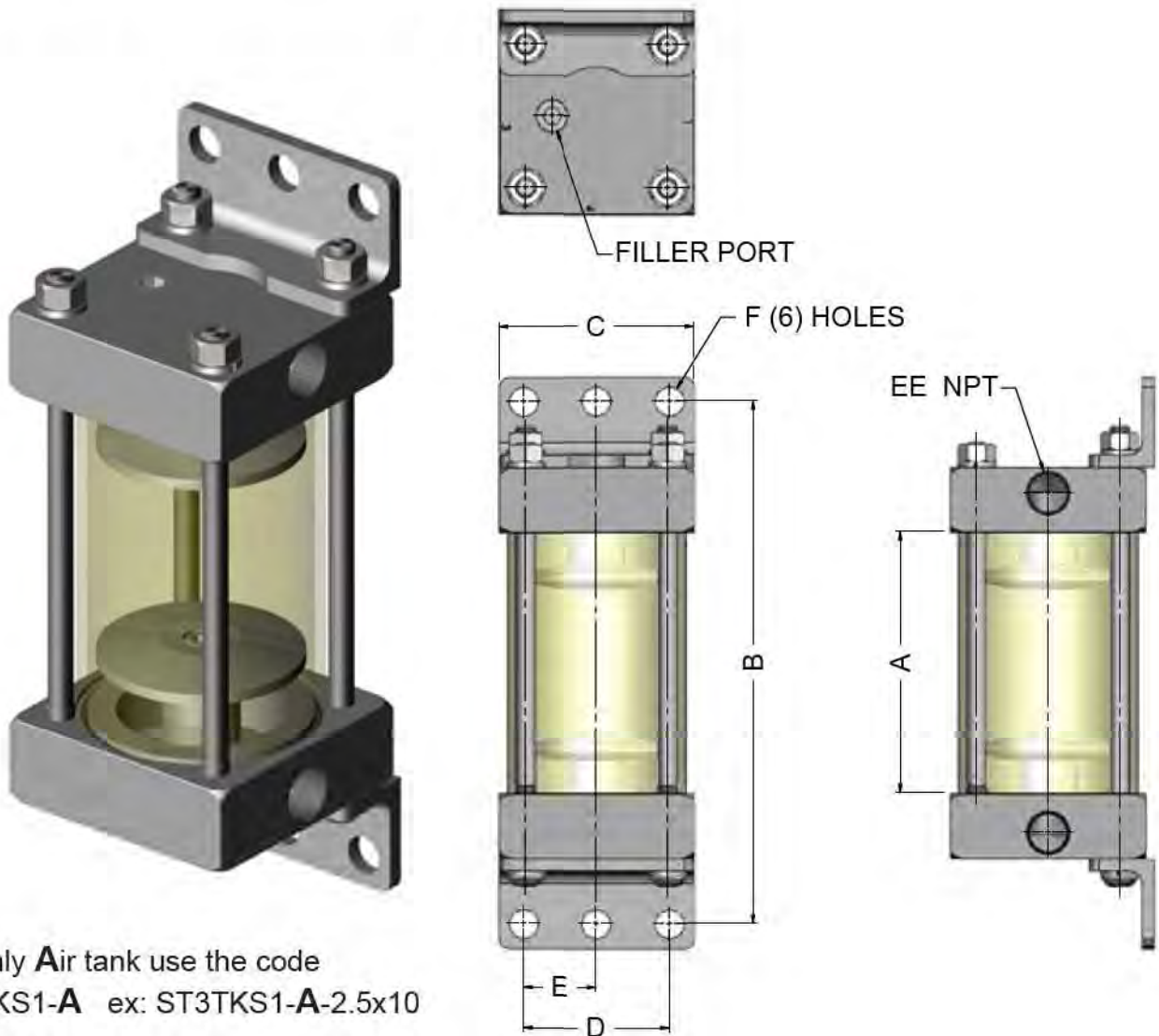

For only Air tank use the code
ST3TKS1-A ex: ST3TKS1-A-2.5x10

PART NUMBER & VOLUME				TANK DIMENSIONS						
PART NO.	BORE	AREA	GALS PER INCH OF TANK	+ INTERNAL LENGTH		C	D	E	F	EE
				A	B					
ST3TKS1-2.5	2.50	4.90	0.0213	0	4	3	2 1/4	1 1/8	7/16	3/8
ST3TKS1-3.25	3.25	8.29	0.0359	0	5	3 3/4	2 3/4	1 3/8	9/16	1/2
ST3TKS1-4	4.00	12.56	0.0544	0	5	4 1/2	3 1/2	1 3/4	9/16	1/2
ST3TKS1-5	5.00	19.64	0.0850	0	5 1/4	5 1/2	4 1/4	2 1/8	11/16	1/2
ST3TKS1-6	6.00	28.00	0.1224	0	5 3/4	6 1/2	5 1/4	2 5/8	13/16	3/4
ST3TKS1-8	8.00	50.26	0.2175	0	6 5/8	8 1/2	7 1/8	3 9/16	13/16	3/4

HOW TO ORDER : Just use the internal length as suffix to the part number
Ex: ST3TKS1-2.5X10. Min Internal length (A) with Baffles: 3"

STAR3 CYLINDERS - Air/Oil Tank

AIR/OIL TANK (ST3TKS4)

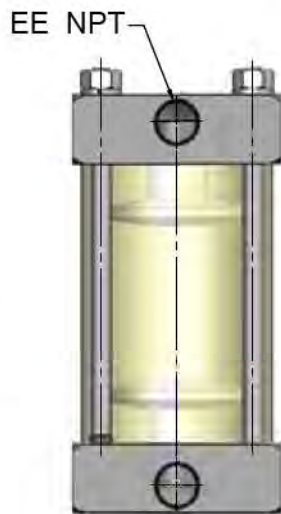
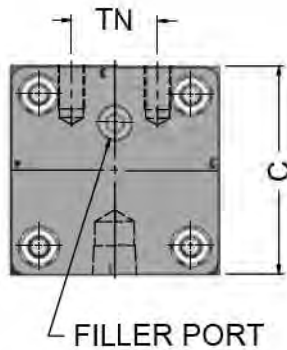

NT THREAD, TK DEEP
4 TAPPED HOLES

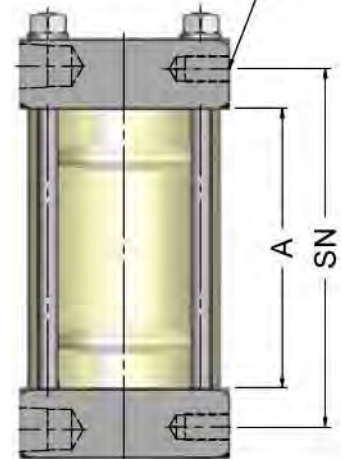

For only **A**ir tank use the code
ST3TKS4-**A** ex: ST3TKS4-**A**-2.5x10

PART NUMBER & VOLUME				TANK DIMENSIONS						
				+ INTERNAL LENGTH						
PART NO.	BORE	AREA	GALS PER INCH OF TANK	A	SN	C	TN	NT	TK	EE
ST3TKS4-2.5	2.50	4.90	0.0213	0	1 1/8	3	1 1/4	3/8-16	5/8	3/8
ST3TKS4-3.25	3.25	8.29	0.0359	0	1 3/8	3 3/4	1 1/2	1/2-13	3/4	1/2
ST3TKS4-4	4.00	12.56	0.0544	0	1 3/8	4 1/2	2 1/16	1/2-13	3/4	1/2
ST3TKS4-5	5.00	19.64	0.0850	0	1 3/8	5 1/2	2 11/16	5/8-11	1	1/2
ST3TKS4-6	6.00	28.00	0.1224	0	1 5/8	6 1/2	3 1/4	3/4-10	1 1/8	3/4
ST3TKS4-8	8.00	50.26	0.2175	0	1 5/8	8 1/2	4 1/2	3/4-10	1 1/8	3/4

HOW TO ORDER : Just use the internal length as suffix to the part number
Ex: ST3TKS4-2.5X10. Min Internal length (A) with Baffles : 3"

STAR3 CYLINDERS - NON ROTATING/SIDE

NON ROTATING EXTERNAL SINGLE (OPTION -NRE)

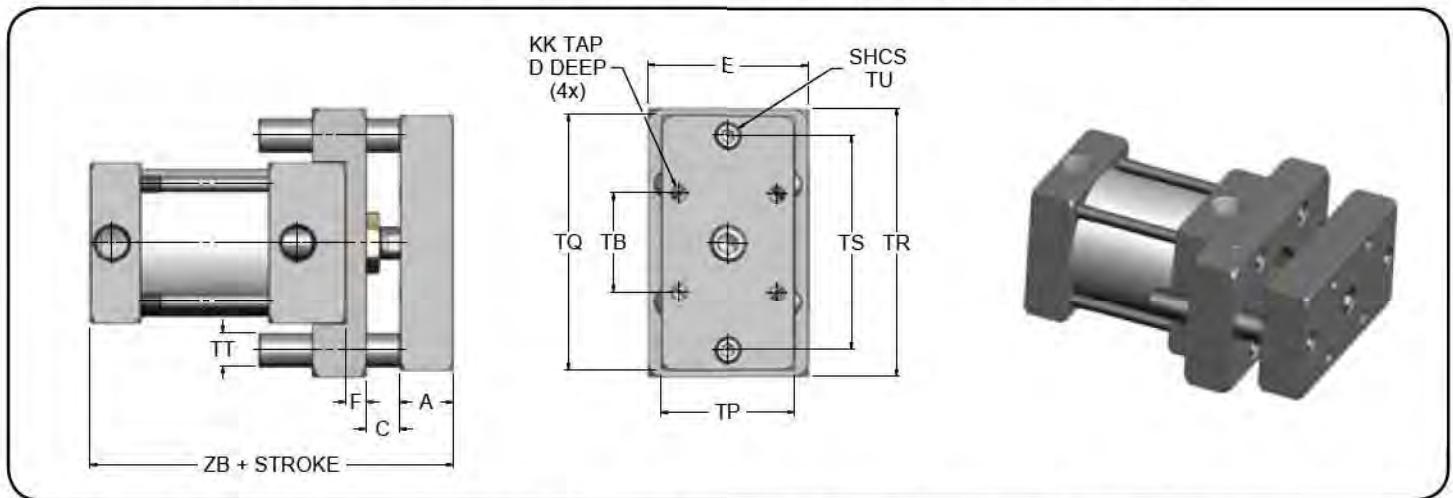

NON ROTATING EXTERNAL DOUBLE (OPTION -NRED)

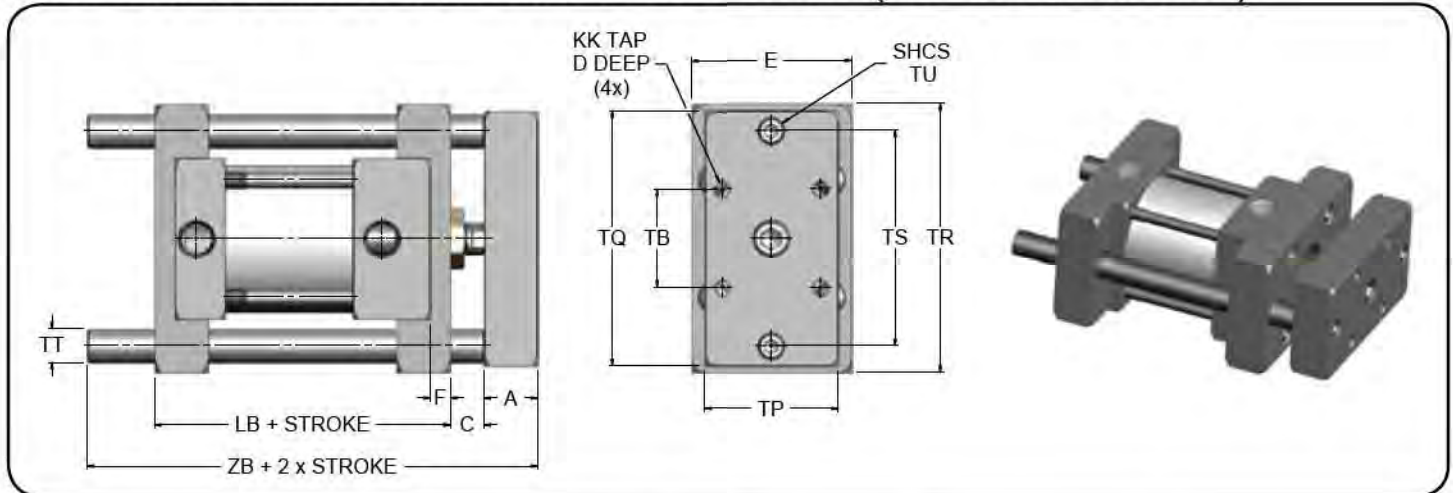

-NRE AND -NRED DIMENSIONS							
Bore	1.5	2	2.5	3.25	4	5	6
A	1	1	1	1 1/4	1 1/4	1 1/4	1 1/2
C	5/8	5/8	5/8	3/4	3/4	3/4	7/8
D	3/4	3/4	1	1	1	1 1/4	1 1/2
E	2	2 1/2	3	3 3/4	4 1/2	5 1/2	6 1/2
F	3/8	3/8	3/8	5/8	5/8	5/8	3/4
KK	10-32	1/4-28	5/16-24	3/8-24	3/8-24	1/2-20	1/2-20
TB	1.12	1.43	1.84	2.19	2.78	3.32	4.12
TP	1 1/2	2	2 1/2	3	3 3/4	4 1/2	5 1/2
TQ	3 3/4	4 1/4	4 3/4	6 1/2	7 1/4	8 1/4	10
TR	4	4 1/2	5	6 3/4	7 1/2	8 1/2	10 1/2
TS	3	3 1/2	4	5 1/4	6	7	8 1/2
TT	5/8	5/8	5/8	1	1	1	1 3/8
TU	5/16-24	5/16-24	5/16-24	1/2-20	1/2-20	1/2-20	5/8-18
ZB	5 5/8	5 5/8	5 3/4	6 7/8	6 7/8	7 1/8	8 1/8

STAR3 CYLINDERS - Accessories



NFPA CLEVIS BRACKET

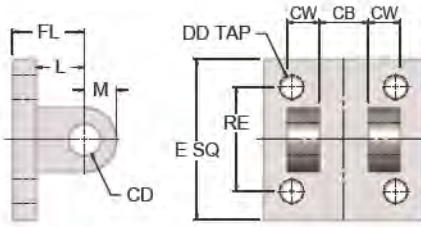

Part #	CB	CD PIN DIA.	CW	DD	E	FL	L	M	RE	USED WITH MP4
CB-05	.765	1/2	1/2	3/8-24	2 1/2	1 1/8	3/4	1/2	1 5/8	1.5, 2 & 2.5
CB-07	1.265	3/4	5/8	1/2-20	3 1/2	1 7/8	1 1/4	3/4	2 9/16	3.25, 4 & 5
CB-10	1.515	1	3/4	5/8-18	4 1/2	2 1/4	1 1/2	1	3 1/4	6, 7 & 8
CB-13	2.032	1 3/8	1	5/8-18	5	3	2 1/8	1 3/8	3 13/16	8, 10 & 12
CB-17	2.531	1 3/4	1 1/4	7/8-14	6 1/2	3 1/8	2 1/4	1 3/4	4 15/16	10 & 12

NFPA EYE BRACKET

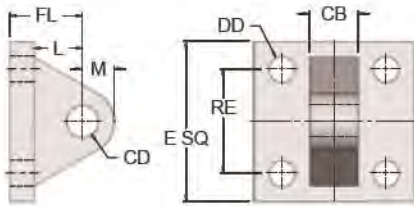

Part #	CB	CD PIN DIA.	DD	E	FL	L	M	RE	USED WITH MP1 & MP2
EB-05	.750	1/2	13/32	2 1/2	1 1/8	3/4	1/2	1 5/8	1.5, 2 & 2.5
EB-07	1.25	3/4	17/32	3 1/2	1 7/8	1 1/4	3/4	2 9/16	3.25, 4 & 5
EB-10	1.50	1	21/32	4 1/2	2 1/4	1 1/2	1	3 1/4	6, 7 & 8
EB-13	2.00	1 3/8	21/32	5	3	2 1/8	1 3/8	3 13/16	8, 10 & 12
EB-17	2.50	1 3/4	29/32	6 1/2	3 1/8	2 1/4	1 3/4	4 15/16	10 & 12

NFPA ROD CLEVIS

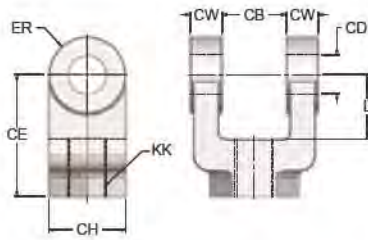

Part #	CB	CD PIN DIA.	CE	CH HEX.	CW	ER	KK	L
RC-05	.765	1/2	1 1/2	1	1/2	1/2	7/16-20	3/4
RC-07	1.265	3/4	2 3/8	1 1/4	5/8	3/4	3/4-16	1 1/4
RC-10	1.515	1	3 1/8	1 1/2	3/4	1	1-14	1 1/2
RC-13	2.032	1 3/8	4 1/8	2	1	1 3/8	1 1/4-12	2 1/8
RC-17	2.531	1 3/4	4 1/2	2 3/8	1 1/4	1 3/4	1 1/2-12	2 1/4
RC-20	2.531	2	5 1/2	15/16ch	1 1/4	2	1 7/8-12	2 1/2

NFPA ROD EYE

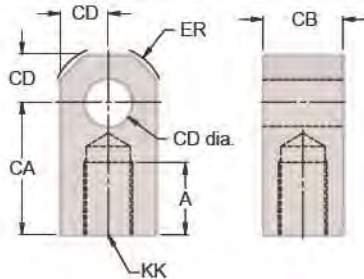

Part #	A	CA	CB	CD PIN DIA.	ER	KK
RE-05	3/4	1 1/2	3/4	1/2	5/8	7/16-20
RE-07	1 1/8	2 1/16	1 1/4	3/4	7/8	3/4-16
RE-10	1 5/8	2 13/16	1 1/2	1	1 3/16	1-14
RE-13	2	3 7/16	2	1 3/8	1 9/16	1 1/4-12
RE-17	2 1/4	4	2 1/2	1 3/4	2	1 1/2-12
RE-20	3	5	2 1/2	2	2 1/2	1 7/8-12

NFPA PIN

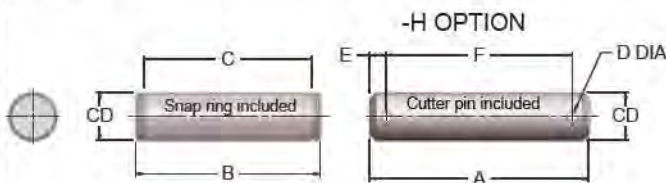

Part #	CD	A	B	C	D	E	F
P-05	1/2	2.281	2.094	1.875	0.106	0.172	1.938
P-07	3/4	3.094	2.875	2.625	0.140	0.188	2.719
P-10	1	3.594	3.375	3.125	0.140	0.188	3.219
P-13	1 3/8	4.656	4.485	4.187	0.173	0.203	4.25
P-17	1 3/4	5.656	5.547	5.188	0.173	0.219	5.250
P-20	2	5.719	5.547	5.188	0.204	0.234	5.281

STAR3 CYLINDERS - Rod and stop tube selection

ROD DIAMETER CHART

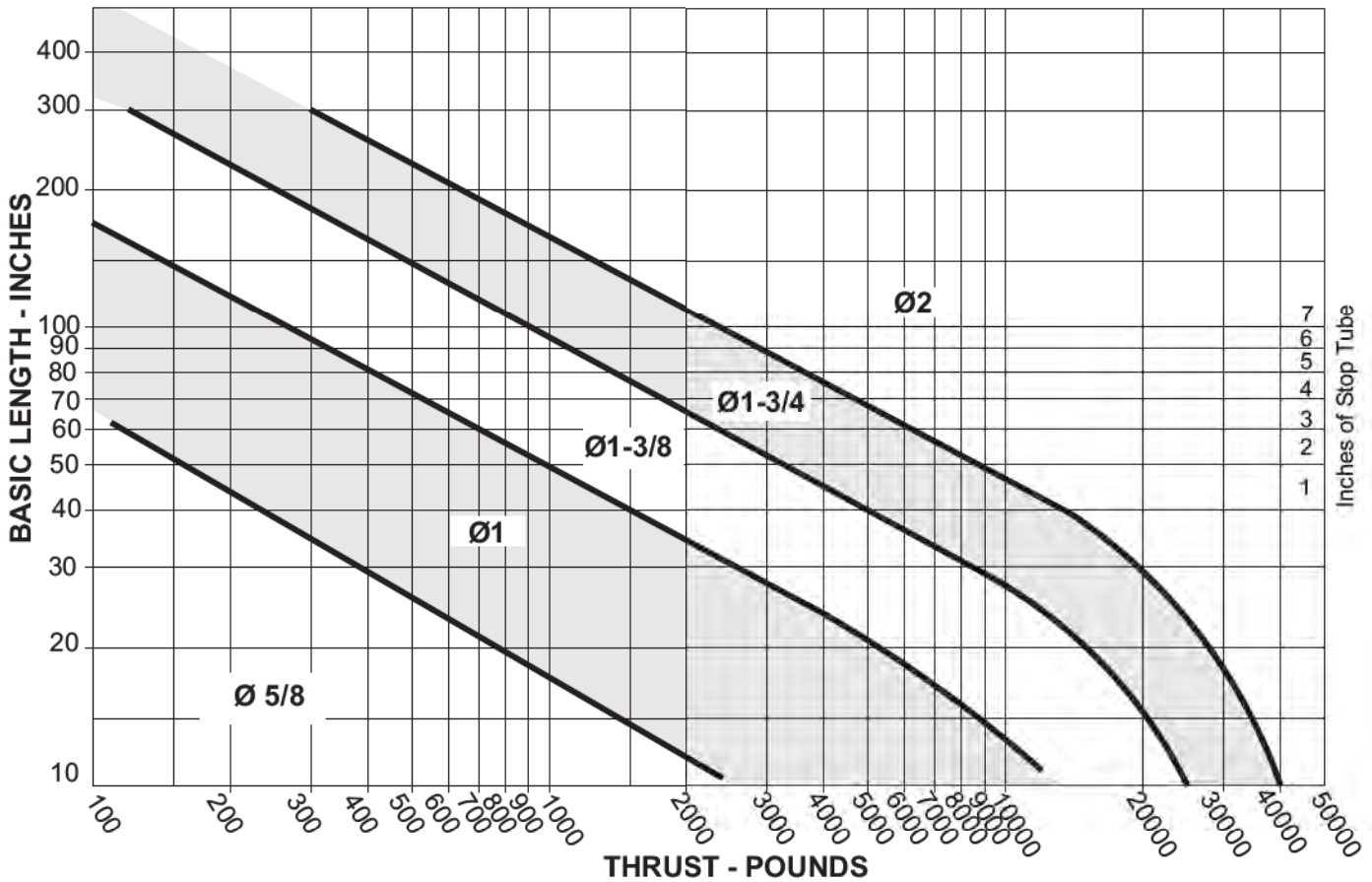

ROD SIZE SELECTION

To determine the minimum recommended piston rod dia for your application:

- 1) Determine the cylinder thrust using the force volume chart. (Page 4) (Thrust equals bore area multiplied by the operating pressure.)
- 2) Select from the diagram beside the type of mounting you will use.
- 3) Determine the basic length by multiplying the real stroke by the stroke factor.
- 4) Enter the graph along the values of "basic length" and "Thrust".

The stripe within which these lines intersect represents the minimum recommended piston rod diameter.

STOP TUBE SELECTION

Stop tubes are installed between the piston and the head on long stroke cylinders to reduce the load on the bearing. That, in turn, reduces bearing wear and tendency to buckle.

To determine if a stop tube is required and, if so, its length, first determine the "basic length" from the diagram. Step 1, 2 & 3 of The Rod Selection.

If the "basic length" is less than 40", no stop tube is needed. If its over than 40", a one-inch stop tube is recommended for every 10" (or fraction thereof) over 40"
See Page 30 on Stop Tube Option and how to Order

MOUNTING STYLE		ROD END CONNECTION	STROKE FACTOR
Center line Mounting Centerline mounting places the mounting bolts in simple shear or simple tension so that the mechanism is protected from compound forces. Centerline mounting is a rigid mounting style and this requires accurate cylinder alignment to prevent damage to the cylinder working parts. Mountings are : MX1, MX2, MX3, MF1, MF2, ME3, ME4.		<p>Fixed & Rigidly Guided</p>	0.50
		<p>Pivoted & Rigidly Guided</p>	0.70
Foot Mounting Foot mounting secures the cylinder along its side. Since the mounting surface plane is thus not centered directly on the line of force, the mounting bolts are subjected to a significant amount of shear stress. Because foot mounts are rigid, they require accurate cylinder alignment. Mountings are : MS1, MS2, MS4, MS7.		<p>Supported but not Rigidly Guided</p>	2.00
		<p>Unsupported</p>	4.00
Pivot Mounting Pivot mounting is used when the cylinder must pivot during piston motion. Clevis and Trunnion mounts are two methods used to allow this motion. The Clevis end design locates the pivot point at the cap end of the cylinder. Trunnion mounting uses the head or the cap of the cylinder to allow it to pivot at any of the two locations. The Mountings are: MP1, MP2, MP4, MT1, MT2, MT4.	MT1 TRUNNION ON HEAD END	<p>Pivoted & Rigidly Guided</p>	1.00
	MT4 INTERMEDIATE TRUNNION	<p>Pivoted & Rigidly Guided</p>	1.50
	MT2 TRUNNION ON CAP END	<p>Pivoted & Rigidly Guided</p>	2.00
	MP1, MP2, MP4 CLEVIS ON CAP	<p>Pivoted & Rigidly Guided</p>	2.00

STAR3 CYLINDERS - Options

Stop Tube Design

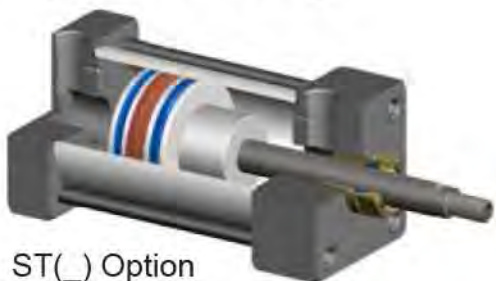

ST(_) Option

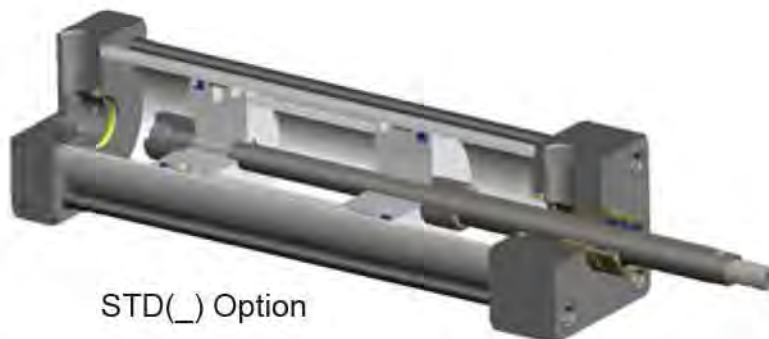
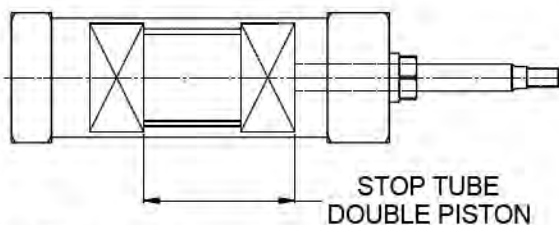
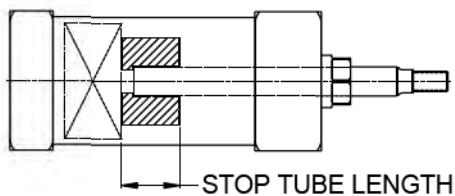

STD(_) Option

Stop Tube

Option Code **ST(_)** or **STD(_)**

Enhances the transverse load carrying capability of a long stroke cylinder by increasing the distance between the piston and the rod bearing at full extension when placed on head end. Ideal for applications requiring longer strokes or where additional rod stability is desired. Specify stop tube length when ordering.

Starcyl supplies two types of stop tubes for air cylinders. A cylinder with over two inches of stop tube, cushioned or not, utilizes dual piston construction **STD(_)** option for added bearing surface as well increasing distance between bearings. A cylinder requiring a stop tube under two inches uses a spacer only and only non cushion **ST(_)** Option.

How To Order Stop Tube option

ex: ST3-3.25x60-STD4 is a 3.25" bore with 60" Net stroke and a dual piston stop tube of 4" long, for a total gross stroke of 64" (must be used to calculate overall length "LB").

Linear Alignment Couplers

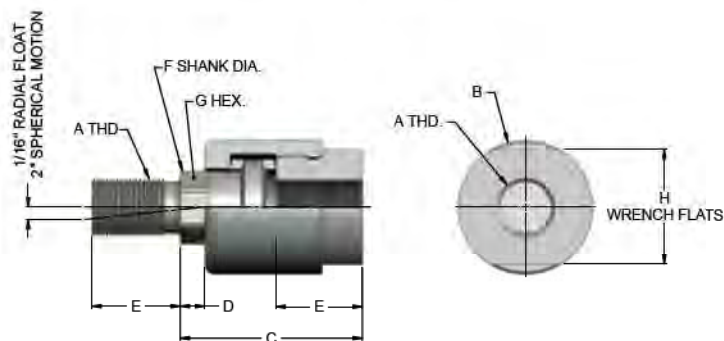

Starcyl's linear alignment couplers extend the bearing and seal life of your cylinders. Our couplers prevent binding and erratic movement that misalignment causes, which eventually wears down your cylinders. Not only do Starcyl couplers work equally well in "push" and "pull" applications, but they allow a greater tolerance between the cylinder center line and the mating member.

* Use jam nut to lock coupler to rod when used with full diameter threads.

Part #	A	B	C	D	E	F	G	H	MAX PULL AT YIELD
AC-250F	1/4-28	7/8	1 1/4	1/4	5/8	0.245	3/16	13/16	8000
AC-312F	5/16-24	7/8	1 1/4	1/4	5/8	0.308	1/4	13/16	8300
AC-375C	3/8-16	7/8	1 1/4	1/4	5/8	0.389	5/16	13/16	5000
AC-375F	3/8-24	4/8	1 1/4	1/4	5/8	0.370	5/16	13/16	8300
AC-437F	7/16-20	7/8	2	1/2	3/4	5/8	9/16	1 1/8	10000
AC-500C	1/2-13	1 1/4	2	1/2	3/4	5/8	9/16	1 1/8	14000
AC-500F	1/2-20	1 1/4	2	1/2	3/4	5/8	9/16	1 1/8	14000
AC-625F	5/8-18	1 1/4	2	1/2	3/4	5/8	1/2	1 1/8	14000
AC-750C	3/4-10	1 3/4	2 5/16	5/16	1 1/8	31/32	7/8	1 1/2	34000
AC-750F	3/4-16	1 3/4	2 5/16	5/16	1 1/8	31/32	7/8	1 1/2	34000
AC-875F	7/8-14	1 3/4	2 5/16	5/16	1 1/8	31/32	7/8	1 1/2	34000
AC-1000C	1-8	2 1/2	2 15/16	1/2	1 5/8	1 3/8	1 1/4	2 1/4	84000
AC-1000F	1-14	2 1/2	2 15/16	1/2	1 5/8	1 3/8	1 1/4	2 1/4	84000
AC-1250F	1 1/4-12	2 1/2	2 15/16	1/2	1 5/8	1 3/8	1 1/4	2 1/4	84000
AC-1375F	1 3/8-12	2 1/2	2 15/16	1/2	1 5/8	1 3/8	1 1/4	2 1/4	84000
AC-1500F	1 1/2-12	3 1/4	4 3/8	13/16	2 1/4	1 3/4	1 1/2	3	134000
AC-1750F	1 3/4-12	3 1/4	4 3/8	13/16	2 1/4	1 3/4	1 1/2	3	134000
AC-1875F	1 7/8-12	3 3/4	5 7/16	11/16	3	2 1/4	1 7/8	3 1/2	240000
AC-200F	2-12	3 3/4	5 7/16	11/16	3	2 1/4	1 7/8	3 1/2	240000

STAR3 CYLINDERS - Hall Effect & Reed switches

Reed switches are constructed of two overlapping ferromagnetic reeds which are sealed in a glass tube with the ends aligned and a small gap between them. When an external magnetic force is applied, the reed assumes opposite polarity, the ends of the reeds attract each other and make contact, completing the circuit. Reed switches are not recommended in sensitive areas since they can introduce electrical noise into the circuit due to bounce and vibration from mechanical closing of the reeds.

Hall Effect switches are solid state switches with no moving parts. The solid state switches is activated when the silicon chip (Hall) senses a magnetic field. Since there are no moving parts, Hall effect switches can operate in sensitive areas without sending interference or noise into the circuit.

Switch specifications

Switch part Number	862-100-004	862-100-031	862-100-032
Spec	Reed switch, MOV, LED	Electronic Sensor, LED, Sourcing	Electronic Sensor, LED, Sinking
Cable Length	9 ft PVC Cable		
Switching Voltage	5-120 VDC/VAC 50/60 Hz	6-24 VDC	6-24 VDC
Switching Current	0.5 Amp Max .005 Amp Min	0.5 Amp Max	0.5 Amp Max
Switching Power	10 Watts Max.	12 Watts Max.	12 Watts Max.
Switching Speed	0.5 μ s operate 0.1 μ s release	1.5 μ s operate 0.5 μ s release	0.5 μ s operate 0.1 μ s release
Voltage Drop	3.5 Volts	1.0 Volts	1.0 Volts
Temperature Range	-20° to 80°C -4° to 176°F		
Switch Function	SPST Normally Open	Normally Open PNP output	Normally Open NPN output
Shock	Up to 30G (11 msec.)	-	-
Vibration	Up to 20G (10-55 Hz)	-	-

Wiring Diagrams

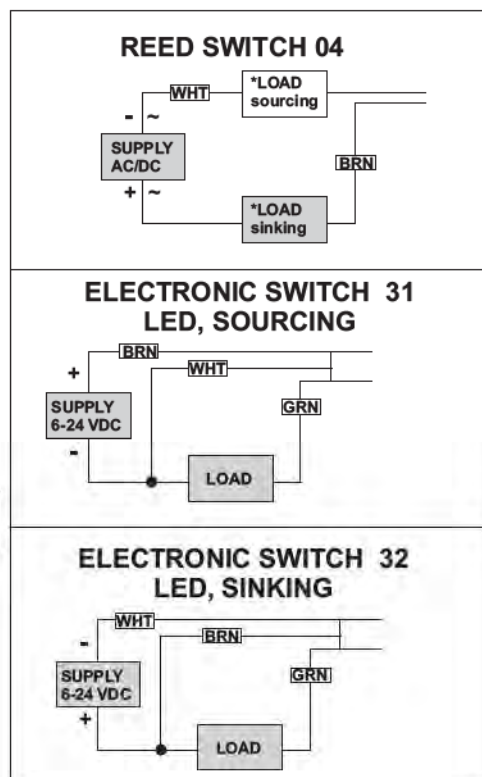

How To Order

862 - 100 - X XX

Series	Connections	Type Code
862	0 - 9ft PCV wire	02 - Reed switches
762	1 - 8 mm Quick Connect with Pigtail (std)	04 - Reed switches
	3 - 8 mm Quick Connect	31 - Hall Effect PNP
		32 - Hall Effect NPN

To Order Switch Clamp Use: (no charge when ordered with switches)

A clamp = 800-A00-000

B clamp = 800-B00-000

C clamp = 800-C00-000

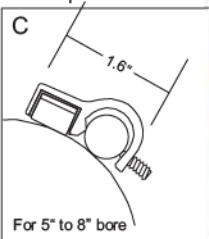
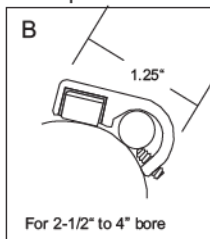
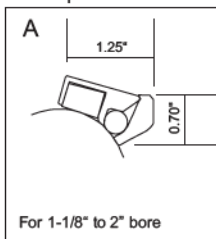

Clamp dimensions



STAR3 CYLINDERS - Basic Options

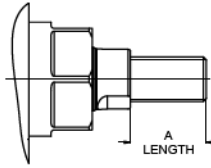

Thread Extension

Option code TE

Piston Rod Thread Extension can be ordered over standard. To order add option code **TE()** and specify "A" length.

Ex: ST3-3.25X4-TE2 will have an additional 7/8" to the standard 1-1/8" thread length.

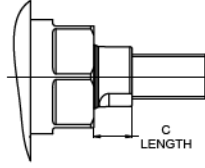

Rod Extension

Option code RE

Piston Rod Extension can be order over standard. To order add option code **RE()** and specify "C" length
Ex: ST3-3.25X4-RE1.5 will have an additional 1" to the standard C=1/2".

Port & Adjustable Cushion Location

Option code P()C()

Specify optional location, P11C22 default

For standard head and cap relocation use: Ex

P13C24 , is Port head in 1, Cap port in 3, Cushion Head in 2, Cushion cap in 4. ex: P1C3 can be use when head & cap are similar. **CUSHION STANDARD FROM 1.5 TO 5" BORE (C22)**

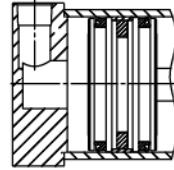
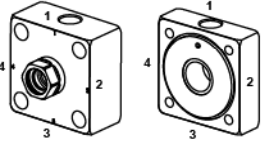

Magnetic Piston

Option Code M

When position sensing of the cylinder is required, a Magnetic Ring Must be added. The Magnetic ring is placed at the center of the piston under the wear band. The magnetic band will create a magnetic field which will actuate the sensor. Option code **M**

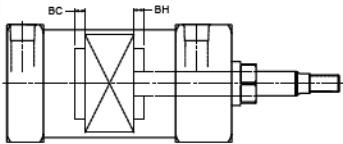

Bumper

Option code HB, CB & B

Urethane impact dampening bumpers, used when speeds do not allow for standard cushions. CB=Cap Bumper, HB=Head Bumper, B=Bumper Both ends (note: each bumper reduces 1/8" to cylinder length)

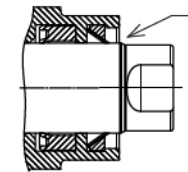

Metallic Rod Scraper

Option RS

Aggressively Scrapes the exposed portion of the piston rod free of weld splatter, paint spray, abrasive powders or many other foreign materials that could damage the rod seal.

Electroless Nickel

Option Code EN

The properties of Electroless nickel contribute to the multitude of uses. The coating provides an attractive finish, while exhibiting high abrasion and corrosion resistance. Its ability to uniform coat blind holes, threads, internal surfaces and sharp edges contributes to its effectiveness. It has a very high bonding strength to the base metal. Coating can be done on aluminum, steel, cast iron, etc

Non Adjustable Cushion

Option Code NAC

Mostly use with the IR option, this option consists of removing the two needle valves and a bigger orifice for air escaping by the port when piston spud is sealing the cushion seal. (also cost effective)

Use this option also to avoid people to desajust the needle valve of a cushion that can change the cycle of the machine.

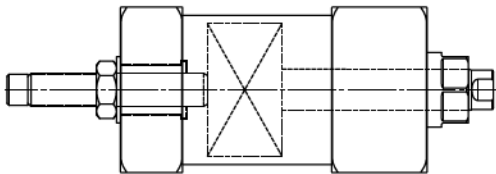

Adjustable Stroke

Option Code ASU()

Provides variable reduction of the retract stroke and serves as a positive stop for the cylinder piston. Consist of a threaded stud located in the cap end of the cylinder. Socket head cap screw loctite at the end of the adjustment stud allow simple yet precise positioning to accommodate varying retract stroke requirements. Must specify adjustment stroke length. Ex: -ASU1.5

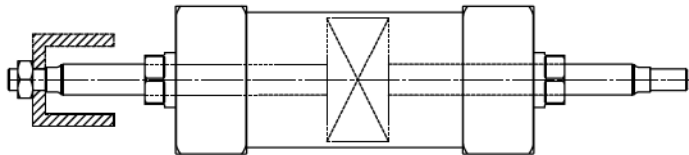

Double rod Adjustable Stroke (Extend)

Option Code ASE()

Consist of a double rod cylinder and a adjustable stop collar. Used to adjust the extend cylinder stroke. Stroke up to 120" available. (Adjustments to 12" available)

To order, Specify ASE and length adjustment.

Ex: ASE4 = 4" of adjustment

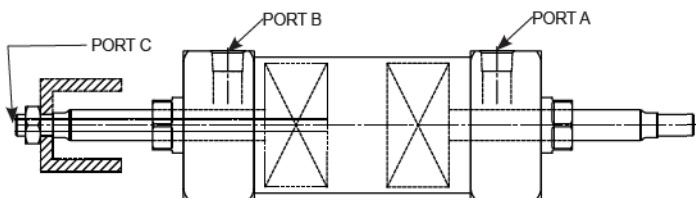

Adjustable Mid Stroke

Option Code ASM()

Design similar to the option ASE, this option consist of a 3 position cylinder with a double piston design that allow adjustment of the mid stroke position. Cylinder with three port and an adjustable collar.

To order, Specify ASM and length adjustment.

Ex: ASM4 = 4" of adjustment

STAR3 CYLINDERS - Basic Options

Low Friction

Option code LF

Low friction option incorporates the use of round lip, Extremely low friction carboxylated nitrile seals. Round lip seals "hydroplane" on opposed sealing surfaces, and have a lower Running and break away friction 2-3 Psi. (Standard seal will have min operating pressure at 5 Psi)

Viton Seals

Option code V

Fluorocarbon will be chosen for higher temperature range from 200°F to 400°F (200°C)
For Chemical resistance our standard Blue Seals will Outstand Viton by far in most chemical Application and wear resistance. Resists most wash down application.

Steel Tubing

Option code STU

For applications requiring a cylinder that can withstand higher side loading, resistance to denting. Starcyl has offered Steel Tubing for years in the Lumber, Mine and other industries that typically used 100% all steel Cylinders. (Hydraulic grade steel tubing honed with **StarNite** ID and OD Corrosion Resistant with a hard layer on the ID and OD for wear resistance.

Stainless Steel Tie rods and Rod

Option Code SST & SSR

SST : Stainless Tie rods, Available in stainless 303/304
SSR: Stainless Piston Rod, Available in Stainless 304 or Hard Chrome 303
(Please note that our **StarNite** process can be used to replace Stainless in most application that require Corrosion resistance with a better cost, resistant to Caustic WashDown)

Under Size Port

Option code N1, N2, N3, N4, N6

N1 = 1/8 Npt, N2 = 1/4 Npt, N3= 3/8 Npt, N4 = 1/2 Npt, N6= 3/4 Npt
You can order cylinder with undersize port, require longer lead time if not in stock.

Chrome Rod Or Nitrotec Rod

Option Code CR or NI

We still can supply old technologie, for that matter you can request Chrome Rod Or Nitrotec Rod.

Non Rotating Internal

Option code NRI

Available from 2" through 12" bore.

Design with one or two Guide Rods internally, keeps all external dimensions the same. Application like Pick and place, Clamping, Marking, Pressing.
(IR option not available with this option)

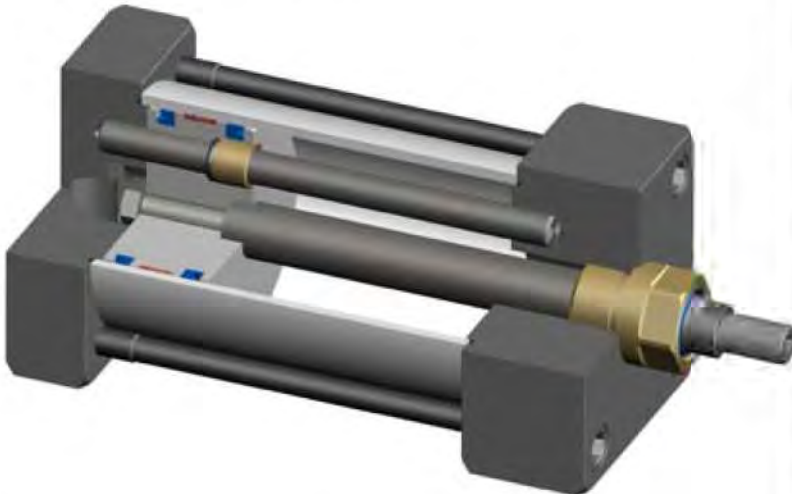

NRI GUIDE ROD SIZES AND MAX STROKE

BORE	ROD DIA.	CUSHIONS	GUIDE ROD DIA	MAX STROKE
2	5/8 standard	N/A	.250	10"
2.5	5/8 standard	N/A	.312	12"
	1" oversize	N/A	.312	12"
3.25	1" Standard	Available	.375	18"
	1 3/8" Oversize	Cap Only	.375	18"
4	1" Standard	Available	.625	30"
	1 3/8" Oversize	Available	.625	30"
5	1" Standard	Available	.625	30"
	1 3/8" Oversize	Available	.625	30"
6	1 3/8" Standard	Available	.625	30"
	1 3/4" Oversize	Available	.625	30"
8	1 3/8" Standard	Available	1.000	40"
	1 3/4" Oversize	Available	1.000	40"
10	1 3/4" Standard	Available	1.000	40"
	2" Oversize	Available	1.000	40"
12	2" Standard	Available	1.000	40"
	2 1/2" Oversize	Available	1.000	40"



Combination of Mounting

Combination mount part numbers can be constructed by adding a Slash (/) between the desired mounts in the part number.

Example: 5" Bore with 12" Stroke, Head and Cap Cushions, Magnetic Piston and having an MS2E and MP2 Mount: Part Number: **ST3S2E/P2-5 X 12-M**

STAR3 CYLINDERS - Basic Options

Hydraulic 400 PSI Non shock

Model Code ST3H

By changing some of the seals the Aluminum Construction cylinder will be able to operate in hydraulic low pressure. (Non Cushion Only)

Your Special Option

Starcyl is well known for their fast response to custom application, so let us quote your special requirements in cylinders. Model Code **SPxxxx**

END OF STROKE SENSOR

Option Code G() & GS()

GO Switches are simple and built to last. With only one moving part and no metal-to-metal contact forcing it to move, there is nothing to wear out!

Must Indicate Position. Ex : G3 switch will be in position 3



Option Code **G**



Option Code **GS**

Options Available

- Explosion Proof
- SPDT or DPDT
- HiTemp™ to 400°F
- SubSea™ Submersible
- Hermetically Sealed
- High Pressure to 10,000 psi

How it Works

When the ferrous cushion of a cylinder enters the sensing area of the switch, it attracts the primary magnet, which pulls the connecting rod forward. As a result, the common contact snaps to its operated position, closing the other contact circuit. When the target is removed the common contact automatically returns to its original unoperated position.

OVER OVERSIZE ROD OPTION



4" bore, 2" rod diameter, triple oversize Rod, with a one pcs steel head trunnion with cushion.
ST3O3T1X-4X8-#2

ROD SIZE AVAILABLE PER BORE

BORE	5/8	1	1 3/8	1 3/4	2	2 1/2	3	3 1/2	4	4 1/2	5
1.5	✓	✓									
2	✓	✓	✓								
2.5	✓	✓	✓	✓							
3.25		✓	✓	✓	✓						
4		✓	✓	✓	✓	✓					
5		✓	✓	✓	✓	✓	✓	✓			
6			✓	✓	✓	✓	✓	✓	✓		
7			✓	✓	✓	✓	✓	✓	✓	✓	
8			✓	✓	✓	✓	✓	✓	✓	✓	✓
10				✓	✓	✓	✓	✓	✓	✓	✓
12					✓	✓	✓	✓	✓	✓	✓

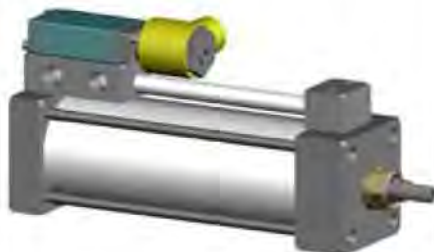

Cylinder with Manifold Cap Mount for the valve and including pipe to the head end with a small manifold. (Explosion Proof Valve Shown)



High Speed Cycling Cylinder with a single Manifold porting the cap as well as the head. (Narrow Namur Valve Shown)



Lifter 4 Post. Ex: 5" bore, 4" stroke, main rod 1.75" dia and the 4 post at 1" dia. The post are garded by thin wall tubing.

STAR3 CYLINDERS - How to Order

ST3 S2 - 4 X 10 - #4 - P2C4* - M

MODEL

MOUNTING

BORE

STROKE

ROD END

OPTIONS

ST3	BASIC MODEL	BASIC MOUNT	1.5	1	#1	MALE, large	B	BUMPER BOTH
ST3O	OVERSIZE ROD	E3 SQUARE HEAD (4 HOLES)	2	2	#1F	MALE, full	CB	BUMPER CAP
		E4 SQUARE CAP (4 HOLES)	2.5	3	#2	MALE, small	HB	BUMPER HEAD
ST3IR	IMPACT REDUCTION	F1 HEAD RECT. FLANGE	3.25	4	#2S	MALE, studded	BC*	BOTH ENDS CUSHION
		F2 CAP RECT. FLANGE	4	5	#4	FEMALE	CC	CAP CUSHION ONLY
ST3D	DOUBLE ROD	P1 SHORT DETACH. CLEVIS	5	6	#5	FLANGE COUPLING	HC	HEAD CUSHION ONLY
ST3H	HYDRAULICS 250 PSI	P2 DETACH CLEVIS	6	7	#6	FLUSH/CHAMFER	NC	NON CUSHION
		P4 DETACH. EYE PIVOT	7	8	#X	SPECIAL ROD END	NAC	NON ADJUSTABLE CUSHION
ST3BB	BACK TO BACK		8	10			P()	PORT POSITION (P1* standard)
ST3TD	TANDEM	S1 ANGLE MOUNT	10	12			C()	CUSHION POSITION (C2* Standard)
ST3MP	MULTI POSITION	S2E SIDE LUG MOUNT	12	ETC			RE()	ROD EXTENSION (specify C dim)
		S2 DETACH SIDE LUG					TE()	THREAD EXTENSION (specify A dim)
ST3T	TRUCK APPLICATION	S4 BOTTOM TAP					RS	ROD SCAPER
		S7 END LUG MOUNT					M	MAGNET
							V	VITON**
		T1 FRONT TRUNNION					AS()	ADJUSTABLE STROKE UP
		T2 REAR TRUNNION					NRE	NON ROTATING EXTERNAL
		T4 INTERMEDIATE TRUNNION					NRED	NON ROTATING EXT .DOUBLE
		X1 BOTH ENDS TIE RODS EXTEND					NRI	NON ROTATING INTERNAL
		X2 CAP END TIE ROD EXTEND					ST()	STOP TUBE
		X3 HEAD END TIE RODS EXTEND					ST/D()	STOP TUBE DOUBLE PISTON

* Leave it blank if it's a standard option

Example : is a STAR3 series, 4" Bore, 10" Stroke, Side Lug Mount, Female rod End, Port Position 2, Cushion Position 4 and with a magnet on the piston.

To order seal kits add the prefix ST3SK to the bore and the rod size ex: ST3SK-4000-1000 (for viton seals add suffix -V).
For Gland Bushing kit add the prefix ST3BK to the rod dia. ex: ST3BK-1000

