



Prices effective March 8, 2010

F-Series Air Cylinders

*Your Exact Interchange
for Stainless Steel Body,
Non-repairable Cylinders*



F Series Direct Interchange Air Cylinders

All the Models Bore-for-Bore!

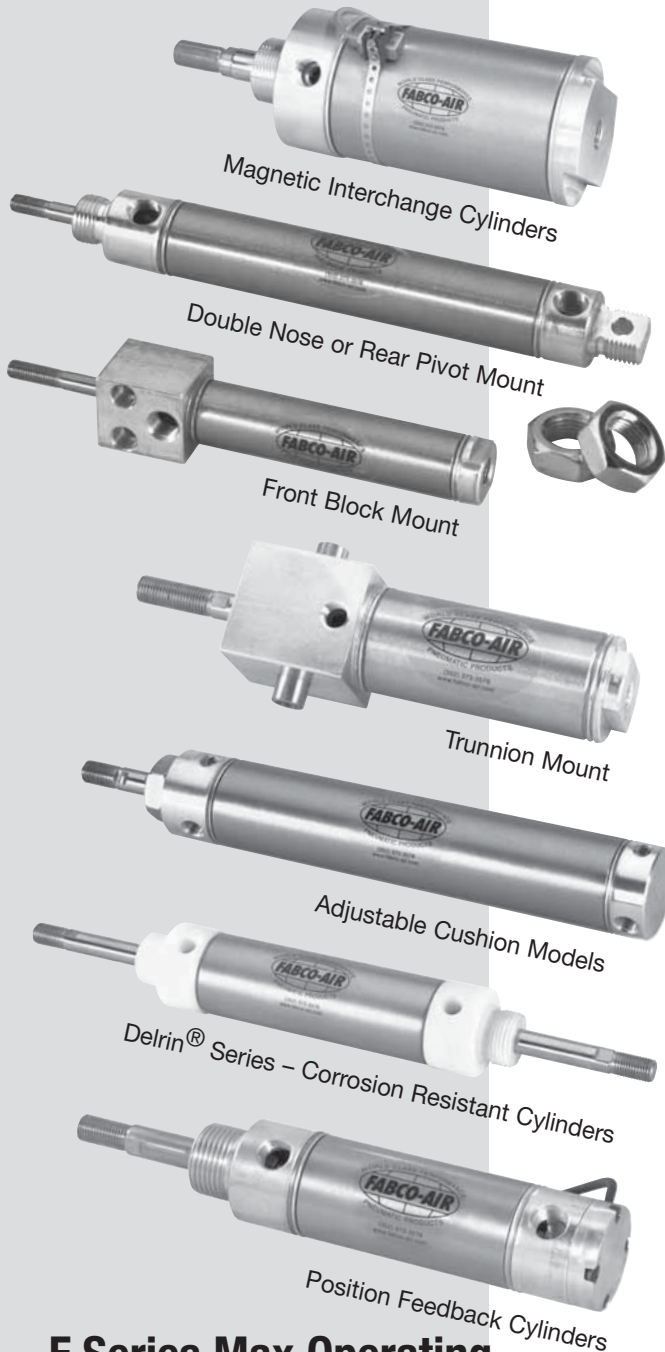

F Series Max Operating Pressure Ratings

F Series Basic Cylinders	250 psi
Adjustable Cushion Cylinders	250 psi
Custom Cylinders 1" Diameter Rod, 2" Bore	250 psi
Volume Chambers	250 psi
Delrin® Series	100 psi
Magnetic Interchange Cylinders	250 psi
Hole Punch Cylinders	250 psi
3-Position Cylinders	250 psi
Position Feedback Cylinders	150 psi

Contents

F Series Ordering Information	2-5
F Series Cylinders and Mounting Accessories	
5/16" Bore	6, 7
7/16" Bore	8-10
9/16" Bore	11-13
3/4" Bore	14-17
7/8" Bore	18-20
1-1/16" Bore	21-24
1-1/4" Bore	25-27
1-1/2" Bore	28-31
1-3/4" Bore	32, 33
2" Bore	34-37
2-1/2" Bore	38
3" Bore	39
Adjustable Cushion Cylinders	
3/4" Bore	16
1-1/16" Bore	24
1-1/2" Bore	30, 31
2" Bore	36
Custom Cylinders	
1" Diameter Rod, 2" Bore	36
Volume Chambers	
Volume chambers, ordering information	40
Delrin® Series – Corrosion Resistant Cylinders	
3/4" Bore	41
1-1/16" Bore	42
1-1/2" Bore	42, 43
Magnetic Interchange Cylinders	
9/16" Bore	44
3/4" Bore	45
1-1/16" Bore	46
1-1/4" Bore	47
1-1/2" Bore	48
1-3/4" Bore	49
2" Bore	50
2-1/2" Bore	51
Hole Punch Cylinders	
3/4" Bore cylinders	54
Punches and assemblies	55
3-Position Cylinders	
Specifications and ordering information	52
3-Position cylinders	53
PFA Series Position Feedback Cylinders	
Cylinder specifications	56, 57
Digital displays specifications	58, 59
Port Mounted Flow Controls	
Molded body	60
Brass body	61
Magnetic Position Sensing	
Sensors	62
Mounting Accessories – Summary	
Dimensions and prices	63

Pre-Lubrication

Factory lube is a special petroleum based oil formulated for long maintenance-free performance.

Rod Bushing

Oil impregnated sintered bronze for excellent wear and long life.

Piston Rod

303 stainless steel, ground, polished, and roller burnished for corrosion-free long life.

Rod Thread

Roll-formed rod threads at both ends provide strength for customer connections as well as the internal piston connection.

Rod Seal

Low friction Buna N "U"-cup seal is inherently wear compensating for long, trouble-free cycle life. Optional low and high temperature seals are available.

Piston

High strength aluminum in all units. Double acting units include air passage to the entire piston and seal area for quick response and full force performance.

Magnet

Piston position indication with reed or electronic sensors. See individual cylinder drawings for length adjustments. See page 62 for sensors.

Ports

Full-flow ports and cross-slots on the end caps allow air passage to the entire piston and seal area for quick response and full force performance.

Crimp

Cylinder body tube and end caps are attached with double rolled-in crimp.

End Caps

Anodized high strength aluminum.

Piston Seals

Low friction Buna N "U"-cups are inherently wear compensating for long, trouble-free cycle life.

Tube

Thin wall 304 stainless steel, drawn and polished for low friction and long life.

Temperature Ranges

Standard Seals -10° to +165°F (-23° to +74°C)
 Low Temperature Seals . . . -40° to +225°F (-40° to +107°C)
 Viton® Seals -15° to +350°F (-26° to +177°C)

Stroke Tolerance = +/- .032

Overall Length Calculations for F Series Cylinders

Single acting F-Series cylinders have stop tubes added for every 1/2" or 1" depending on the bore size. Strokes with no fractional inch simplify the calculation of having a base length plus adder per inch of stroke. However, strokes with fractional inch require more in-depth calculation. The following equations help to calculate the OAL for fractional inch strokes.

Variables:

- OAL** = Overall Length of Cylinder
- S** = Actual Stroke
- B** = Base Length
- STA** = Stop Tube Adder per increment of stroke
- S1** = Stroke rounded up to the next increment (5/16" and 7/16" bores have 1/2" increments)

Note: for 2" bores – use lengths shown on page 34 for whole inch strokes and subtract the difference between desired stroke and next longer standard increment. (Subtract twice for spring extend models.)

Single Acting Spring Return Cylinders

Calculate the length of next whole standard increment of stroke. Then subtract the difference between desired stroke and next longer standard increment of stroke.

OAL = B + (STA x S1) - (S1 - S)

Example: F-1062S01-02M (2-3/4" stroke)

F-1062S01 base length =	1.938
Plus 1.562 per inch of stroke =	<u>+4.686</u>
1.562 x 3.0 (next longer stroke increment)	
F-1062S01-03A length =	6.624
Standard stroke increment =	3.000"
minus desired stroke =	-2.750
Stroke difference =	.250 <u>-2.50</u>
F-1062S01-02M length =	6.374

Double Acting Cylinders

Add desired stroke length to base length of cylinder. **OAL = B + S**

Example: F-0750D01-01E (1-1/4" stroke)

F-0750D01 base length =	2.969
Plus 1.250 stroke =	<u>+1.250</u>
F-0750D01-01E =	4.219

Single Acting Spring Extend Cylinders

Calculate the length of next whole standard increment of stroke. Then subtract twice the difference between desired stroke and next longer standard increment of stroke.

OAL = B + (STA x S1) - 2(S1 - S)

Example: F-0438R02-01K (1-5/8" stroke)

F-0438R02 base length =	2.375
Plus 1.438 per each 0.5" stroke =	<u>+5.752</u>
1.438 x 4.0 (number of standard increments required for the next longer increment)	
F-0438R02-02A length =	8.127
Standard stroke increment =	2.000"
minus desired stroke =	-1.625
Stroke difference =	.375
Twice stroke difference =	.750 <u>-7.50</u>

F-0438R02-01K length = 7.377

F Series

How to Order



Options (2 or 3 digits)
See opposite page

Bore Mounting Stroke Options Rod/Thread Options
F-1500 D01 - 02 A - 01 - 1A00M

Bore Size (4 digits)

0313	=	5/16"
0438	=	7/16"
0563	=	9/16"
0750	=	3/4"
0875	=	7/8"
1062	=	1-1/16"
1250	=	1-1/4"
1500	=	1-1/2"
1750	=	1-3/4"
2000	=	2"
2500	=	2-1/2"
3000	=	3"

Mounting Style (3 digits)

- S01 = Single Acting Spring Return Nose Mount
- S02 = Single Acting Spring Return Rear Pivot
- R01 = Single Acting Spring Extend Nose Mount
- R02 = Single Acting Spring Extend Rear Pivot
- N01 = Single Acting Spring Return Non-Rotating Nose Mount
- N02 = Single Acting Spring Return Non-Rotating Rear Pivot
- D01 = Double Acting Nose Mount
- D02 = Double Acting Rear Pivot
- D03 = Double Acting Double Rod
- D04 = Double Acting Double nose
- D05 = Double Acting Front Block
- D13 = Interchange Option for 1-1/16" Bore
- DH3 = Double Acting Double Rod Hollow Rod
- D06 = Double Acting Trunnion Mount
- DG1 = Double Acting Adjustable Cushion Nose Mount
- DG2 = Double Acting Adjustable Cushion Rear Pivot
- DG4 = Double Acting Adjustable Cushion Double Nose
- DL1 = Double Acting Nose Mount 2" Bore 1" Rod
- DL2 = Double Acting Rear Pivot 2" Bore 1" Rod
- DC1 = Double Acting Delrin® Nose Mount
- DC2 = Double Acting Delrin® Rear Pivot
- DC3 = Double Acting Delrin® Double Rod
- DM1 = Magnetic Interchange, Nose Mount
- DM2 = Mag. Interchange, Nose/Rear Pivot Mt.
- DM3 = Magnetic Interchange, Double Rod

Fractional Inch Stroke

(1 digit)		
A	=	0"
B	=	1/16"
C	=	1/8"
D	=	3/16"
E	=	1/4"
F	=	5/16"
G	=	3/8"
H	=	7/16"
I	=	1/2"
J	=	9/16"
K	=	5/8"
L	=	11/16"
M	=	3/4"
N	=	13/16"
O	=	7/8"
P	=	15/16"

Note: See page 3 for information regarding cylinder length calculations.

Full Inch Stroke (2 digits)

00	=	0"
01	=	1"
02	=	2"
03	=	3"
.		
.		
32	=	32"

See specific cylinder drawings for maximum strokes.

Rod and/or Thread Extension

- 1A _____ = **Rod Extension** (Additional length)
(Code is 1A plus 3 digits)
Example: 1A01A = 1" and no fractional inch extension.
- 2A _____ = **Thread Extension** (Additional length)
(Code is 2A plus 3 digits)
Example: 2A01E = 1-1/4" extension.
- RT _____ = **Rod and Thread Extension** (Additional length)
(Code is RT plus 6 digits; specify rod extension first)
Example: RT02A01M = 2" rod extension and 1-3/4" thread extension

Viton® and Delrin® are registered trademarks of DuPont.
Call DuPont for general information (800) 441-0575 for information regarding properties of these materials.

Standard F Series Options

- 01 = Bumpers
- 02 = Viton Seals
- 03 = Magnet
- 04 = Bumpers, and Magnet
- 05 = Pivot bushing
- 06 = Bumpers, and Pivot Bushing
- 07 = Viton Seals, and Pivot Bushing
- 08 = Magnet, and Pivot Bushing
- 09 = Bumpers, Magnet, and Pivot Bushing
- 20 = Port Rotated w/ No Options
- 30 = Rod Wiper w/ No Options
- 31 = Rod Wiper w/ Bumpers
- 32 = Rod Wiper w/ Viton Seals
- 33 = Rod Wiper w/ Magnet
- 34 = Rod Wiper w/ Bumpers, and Magnet
- 35 = Rod Wiper w/ Pivot bushing
- 36 = Rod Wiper w/ Bumpers, and Pivot Bushing
- 37 = Rod Wiper w/ Viton Seals, and Pivot Bushing
- 38 = Rod Wiper w/ Magnet, and Pivot Bushing
- 39 = Rod Wiper w/ Bumpers, Magnet, and Pivot Bushing
- 50 = Side Port w/No Options
- 100 = Low Temp Seals
- 101 = Low Temp Seals and Bumpers
- 103 = Low Temp Seals and Magnet
- 104 = Low Temp Seals, Bumpers and Magnet
- 105 = Low Temp Seals and Pivot Bushing
- 106 = Low Temp Seals, Bumpers and Pivot Bushing
- 108 = Low Temp Seals, Magnet and Pivot Bushing
- 109 = Low Temp Seals, Bumpers, Magnet and Pivot Bushing
- 200 = Polypak rod seal
- 300 = Polypak piston seal
- 400 = Both Polypak rod and piston seal



Cylinder Pricing Notes

Standard Strokes

- Standard Strokes are those shown for each bore and mounting style.
- Cylinder prices shown are for standard listed strokes.
- Models that include a 1/2" stroke increment, add 50% of the per inch price (round up to the next \$0.01) for the 1/2" of stroke.

Non-Standard Strokes

- Consult factory for price and delivery based on net stroke and quantity.

Rod and/or Thread Extension Pricing Notes

- Consult factory for rod or thread extension on Double Rod styles (D03, D13, DH3, DC3, DM3).
- For rod and/or thread extension increments of 1/2" or less, add 50% of the per inch price (round up to the next \$0.01) for the increment of extension.
- For rod and/or thread extension increments of more than 1/2", use next full inch pricing.

HOW TO ORDER – EXAMPLES

F-0438S01-01A

0438 = 7/16" Bore
 S01 = Single Acting, Spring Return, Nose Mount
 01 = 1" Stroke
 A = .00" Fractional Stroke

F-1062D02-03E-04

1062 = 1-1/16" Bore
 D02 = Double Acting, Rear Pivot Mount
 03 = 3" Stroke
 E = .25" Fractional Stroke
 04 = Bumpers and Magnet

F-1500D04-10I-01-1A02A

1500 = 1-1/2" Bore
 D04 = Double Acting, Double Nose
 10 = 10" Stroke
 I = .50" Fractional Stroke
 01 = Bumpers
 1A02A = 2" Rod Extension

F-2000DG2-20H-03-RT02A01I

2000 = 2" Bore
 DG2 = Double Acting, Adjustable Cushion, Rear Pivot Mount
 20 = 20" Stroke
 H = .4375 Fractional Stroke
 03 = Magnet
 RT02A01I = 2" Rod Extension and 1-1/2" Thread Extension

F Series

5/16" Bore Cylinders



Single Acting Spring Return

Front Nose Mount

Standard Stroke Lengths:

1/2", 1", 1-1/2", 2", 2-1/2", 3", 4"

Maximum Stroke: 4"

Optional Accessories:

- F-M117001 Mounting Bracket
- F-M127001 Rod Clevis

Base Weight: .03 lbs.

Plus .02 lbs. per inch of stroke

F-0313S01-00A

MOUNTING NUT INCLUDED

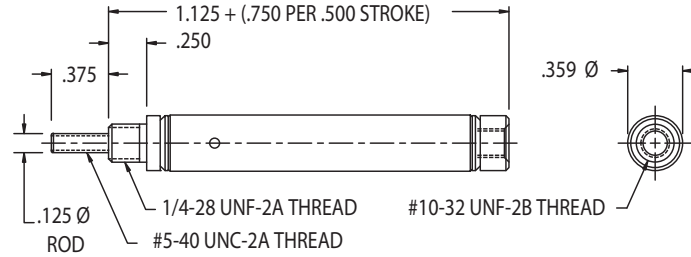

\$11.41 Base Price

Add \$1.97 per inch of stroke

Single Acting Spring Return

Double Nose or Rear Pivot Mount

Standard Stroke Lengths:

1/2", 1", 1-1/2", 2", 2-1/2", 3", 4"

Maximum Stroke: 4"

Optional Accessories:

- F-M117001 Mounting Bracket (with front nose mount)
- F-M117002 Mounting Bracket (with rear nose mount)
- F-M129001 Pivot Bracket
- F-M127001 Rod Clevis

Base Weight: .04 lbs.

Plus .02 lbs. per inch of stroke

F-0313S02-00A

MOUNTING NUT NOT INCLUDED

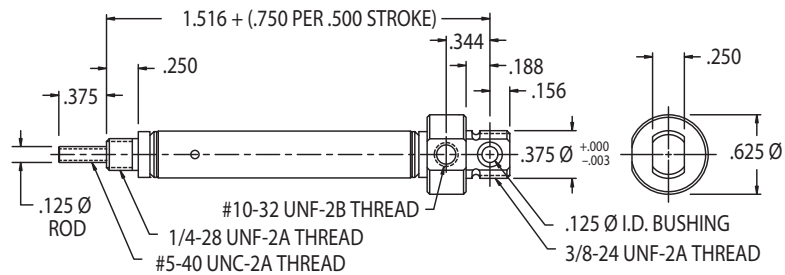

\$14.91 Base Price

Add \$1.97 per inch of stroke

Single Acting Spring Extend

Front Nose Mount

Standard Stroke Lengths:

1/2", 1", 1-1/2", 2", 2-1/2", 3", 4"

Maximum Stroke: 4"

Optional Accessories:

- F-M117002 Mounting Bracket
- F-M127001 Rod Clevis

Base Weight: .05 lbs.

Plus .03 lbs. per inch of stroke

F-0313R01-00A

MOUNTING NUT INCLUDED

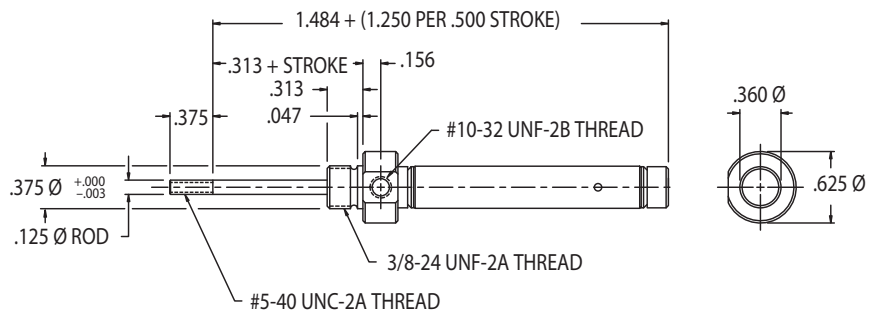

\$17.39 Base Price

Add \$1.97 per inch of stroke

Single Acting Spring Extend

Double Nose or Rear Pivot Mount

Standard Stroke Lengths:

1/2", 1", 1-1/2", 2", 2-1/2", 3", 4"

Maximum Stroke: 4"

Optional Accessories:

- F-M117002 Mounting Bracket
- F-M129001 Pivot Bracket
- F-M127001 Rod Clevis

Base Weight: .05 lbs.

Plus .03 lbs. per inch of stroke

F-0313R02-00A

MOUNTING NUT NOT INCLUDED

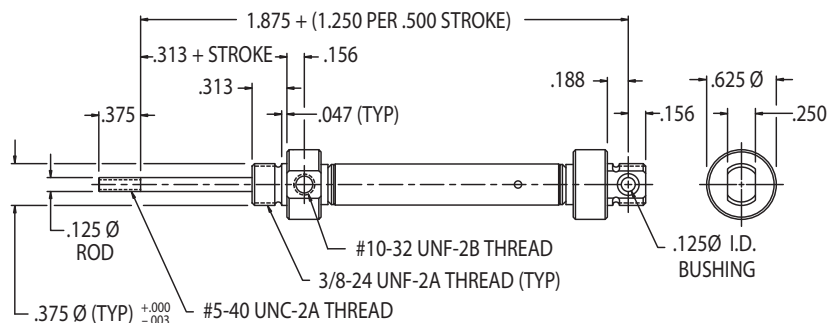

\$22.05 Base Price

Add \$1.97 per inch of stroke

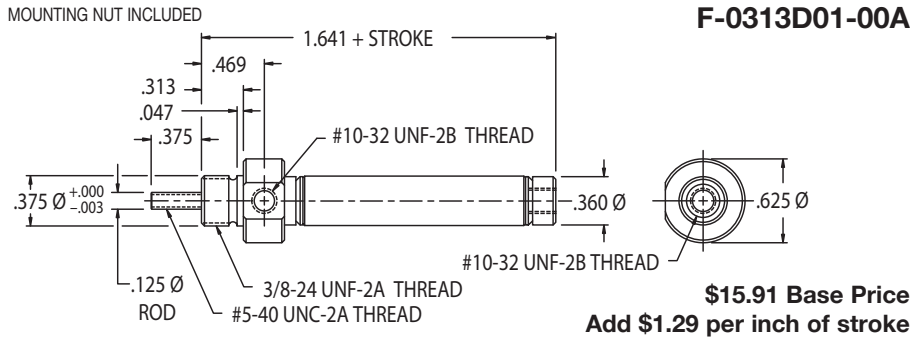

Double Acting
 Front Nose Mount
 Standard Stroke Lengths:
 1/2", 1", 1-1/2" 2", 2-1/2", 3", 4"
 Maximum Stroke: 4"
 Optional Accessories:
 • F-M117002 Mounting Bracket
 • F-M127001 Rod Clevis
 Base Weight: .05 lbs.
 Plus .01 lbs. per inch of stroke

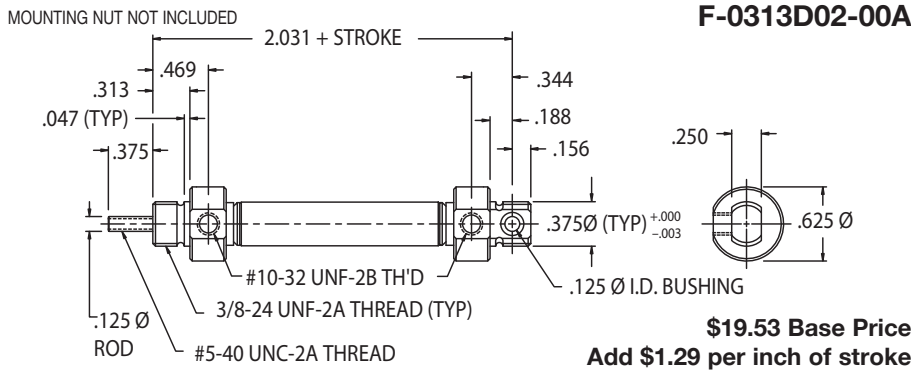

Double Acting
 Double Nose or Rear Pivot Mount
 Standard Stroke Lengths:
 1/2", 1", 1-1/2" 2", 2-1/2", 3", 4"
 Maximum Stroke: 4"
 Optional Accessories:
 • F-M117002 Mounting Bracket
 • F-M129001 Pivot Bracket
 • F-M127001 Rod Clevis
 Base Weight: .06 lbs.
 Plus .01 lbs. per inch of stroke

5/16" Bore Cylinder Features – Options & Accessories

- -10° to +165°F
- Piston Rod: Ground and Polished 303 Stainless Steel
- Mounting nuts are standard on all nose mount cylinders
- Approximate Force Exerted: (0.07) x (Air Line Pressure)
- Spring Force: 0.5 lb. Relaxed – 1 lb. Compressed

OPTION PRICE ADDER

- Viton® Seals –
 - Spring Return (-15° F to 300° F) \$4.01
 - Double Acting (-15° F to 350° F) \$10.74
 - Spring Extend (-15° F to 300° F) \$7.53
- Ports Rotated – 90° on S02, R02, or D02 (both) No charge
- Rod Wipers \$7.10
- Side Port No charge
- Low Temperature Seals – Not available NA
- Rod Extension \$0.63/inch
- Rod Thread Extension \$1.69

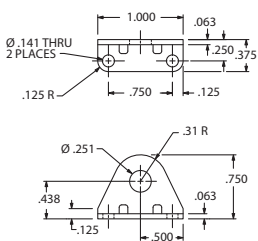

Mounting Bracket
 F-M117001
 Price: \$1.79

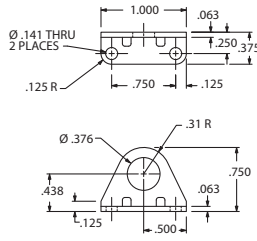

Mounting Bracket
 F-M117002
 Price: \$1.79

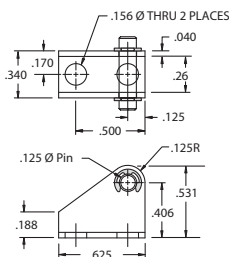

Pivot Bracket
 F-M129001
 Price: \$3.00

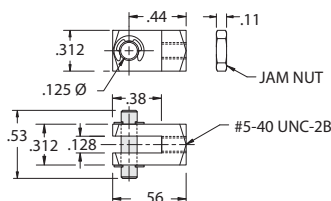

Rod Clevis
 F-M127001
 Price: \$3.00

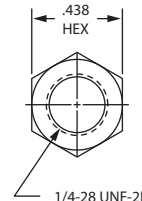

Mounting Nut
 F-M190001
 Price: \$0.26

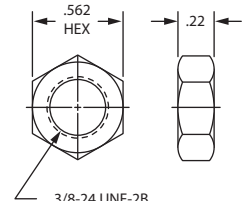

Mounting Nut
 F-M190002
 Price: \$0.26

F Series

7/16" Bore Cylinders



Single Acting Spring Return
Front Nose Mount
 Standard Stroke Lengths:
1/2", 1", 1-1/2", 2", 2-1/2", 3", 4"
 Maximum Stroke: 6"

Optional Accessories:
 • F-M117004 Mounting Bracket
 • F-M127002 Rod Clevis
 Base Weight: .04 lbs.
 Plus .04 lbs. per inch of stroke

F-0438S01-00A

MOUNTING NUT INCLUDED

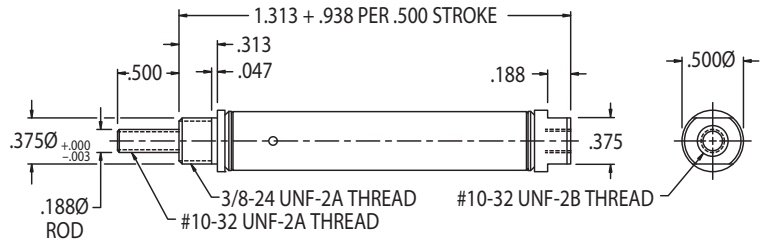

\$11.90 Base Price
Add \$2.23 per inch of stroke

Single Acting Spring Return
Rear Pivot Mount
 Standard Stroke Lengths:
1/2", 1", 1-1/2", 2", 2-1/2", 3", 4"
 Maximum Stroke: 6"

Optional Accessories:
 • F-M117004 Front Mounting Bracket
 • F-M117003 Rear Mounting Bracket
 • F-M029002 Pivot Bracket
 • F-M127002 Rod Clevis
 Base Weight: .04 lbs.
 Plus .04 lbs. per inch of stroke

F-0438S02-00A

MOUNTING NUT NOT INCLUDED

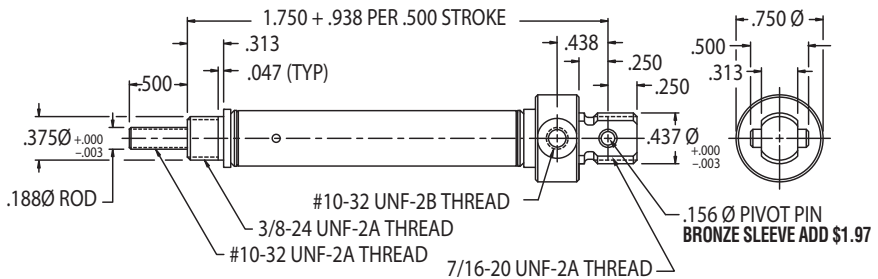

\$15.77 Base Price
Add \$2.23 per inch of stroke

Single Acting Spring Extend
Front Nose Mount
 Standard Stroke Lengths:
1/2", 1", 1-1/2", 2", 2-1/2", 3"
 Maximum Stroke: 6"

Optional Accessories:
 • F-M117003 Mounting Bracket
 • F-M127002 Rod Clevis
 Base Weight: .08 lbs.
 Plus .03 lbs. per inch of stroke

F-0438R01-00A

MOUNTING NUT INCLUDED

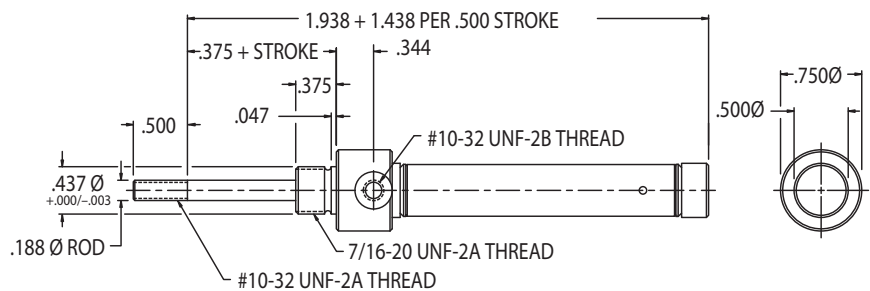

\$18.18 Base Price
Add \$2.23 per inch of stroke

Single Acting Spring Extend
Rear Pivot Mount
 Standard Stroke Lengths:
1/2", 1", 1-1/2", 2", 2-1/2", 3"
 Maximum Stroke: 6"

Optional Accessories:
 • F-M117003 Mounting Bracket
 • F-M029002 Pivot Bracket
 • F-M127002 Rod Clevis
 Base Weight: .08 lbs.
 Plus .03 lbs. per inch of stroke

F-0438R02-00A

MOUNTING NUT NOT INCLUDED

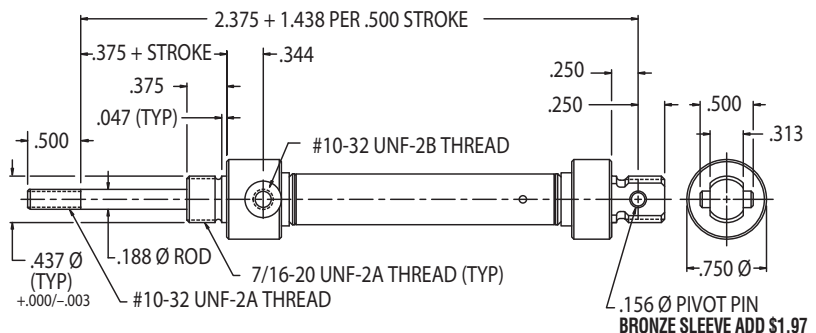

\$22.74 Base Price
Add \$2.23 per inch of stroke

F Series 7/16" Bore Cylinders

MOUNTING NUT INCLUDED

F-0438N01-00A

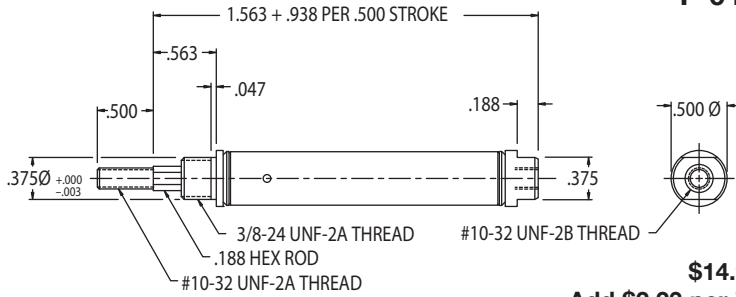

\$14.98 Base Price
 Add \$2.23 per inch of stroke

Single Acting Spring Return
Front Nose Mount

Non-Rotating

Standard Stroke Lengths:

1/2", 1", 1-1/2", 2", 2-1/2", 3", 4"

Maximum Stroke: 6"

Optional Accessories:

- F-M117004 Mounting Bracket
- F-M127002 Rod Clevis

Base Weight: .04 lbs.

Plus .04 lbs. per inch of stroke

MOUNTING NUT NOT INCLUDED

F-0438N02-00A

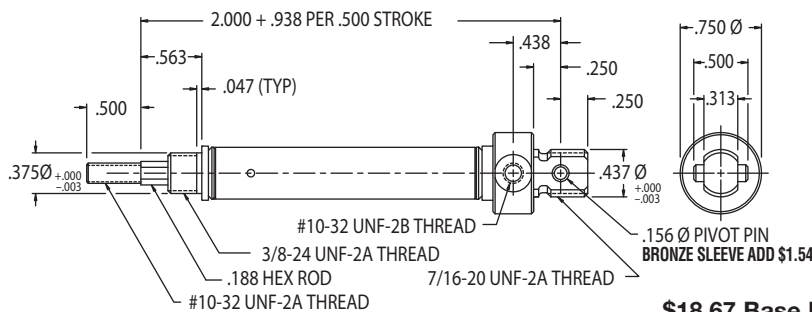

\$18.67 Base Price
 Add \$2.23 per inch of stroke

Single Acting Spring Return
Rear Pivot Mount

Non-Rotating

Standard Stroke Lengths:

1/2", 1", 1-1/2", 2", 2-1/2", 3", 4"

Maximum Stroke: 6"

Optional Accessories:

- F-M117004 Front Mounting Bracket
- F-M117003 Rear Mounting Bracket
- F-M029002 Pivot Bracket
- F-M127002 Rod Clevis

Base Weight: .04 lbs.

Plus .04 lbs. per inch of stroke

MOUNTING NUT INCLUDED

F-0438D01-00A

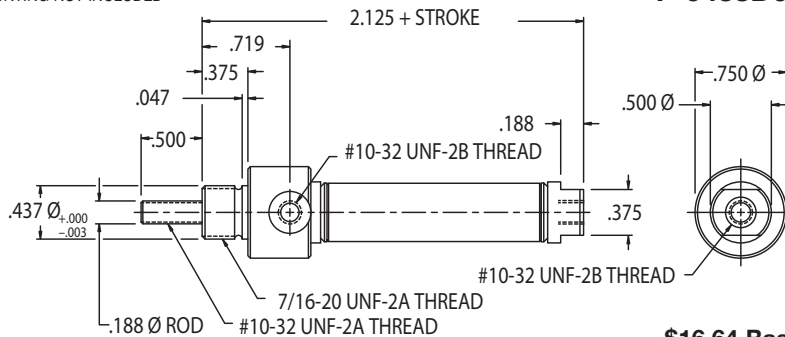

\$16.64 Base Price
 Add \$1.60 per inch of stroke

Double Acting

Front Nose Mount

Standard Stroke Lengths:

1/2", 1", 1-1/2", 2", 2-1/2", 3", 4"

Maximum Stroke: 12"

Optional Accessories:

- F-M117003 Mounting Bracket
- F-M127002 Rod Clevis

Base Weight: .07 lbs.

Plus .02 lbs. per inch of stroke

MOUNTING NUT NOT INCLUDED

F-0438D02-00A

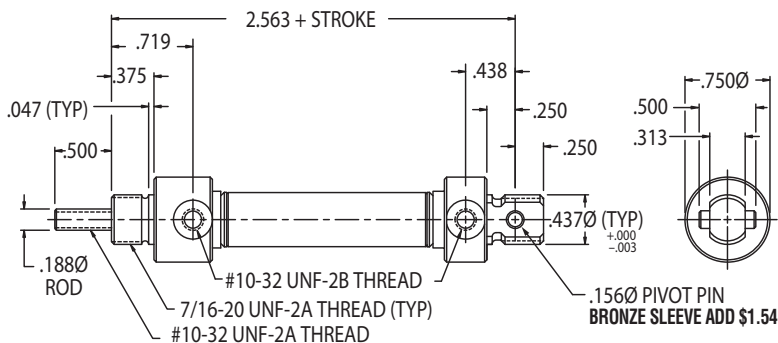

\$20.22 Base Price
 Add \$1.60 per inch of stroke

Double Acting

Rear Pivot Mount

Standard Stroke Lengths:

1/2", 1", 1-1/2", 2", 2-1/2", 3", 4", 5"

Maximum Stroke: 12"

Optional Accessories:

- F-M117003 Mounting Bracket
- F-M029002 Pivot Bracket
- F-M127002 Rod Clevis

Base Weight: .08 lbs.

Plus .02 lbs. per inch of stroke

F Series

7/16" Bore Cylinders



Cylinder Features – Options & Accessories

- -10° to +165°F
- Piston Rod:
Round – Ground and Polished 303 Stainless Steel
Hex – Ground 303 Stainless Steel
- Mounting nuts standard on all nose mount cylinders
- Approximate Force Exerted:
(0.15) x (Air Line PSI)
- Spring Force:
1 lb. Relaxed – 2 lb. Compressed

OPTION	PRICE ADDER
• Viton® Seals –	
Spring Return (-15° F to 300° F)	\$4.20
D01 – Double Acting (-15° F to 350° F)	\$10.96
D02 – Double Acting (-15° F to 350° F)	\$10.84
D03 – Double Acting (-15° F to 350° F)	\$10.36
Spring Extend (-15° F to 300° F)	\$7.71
• Ports Rotated – 90° on S02, R02, N02, or D02 (both).....	No charge
• Rod Wiper	\$7.10
• Side Port.....	No charge
• Low Temperature Seals – Applications to -40° F	\$7.18
• Rod Extension	\$0.74/inch
• Rod Thread Extension.....	\$1.79/inch

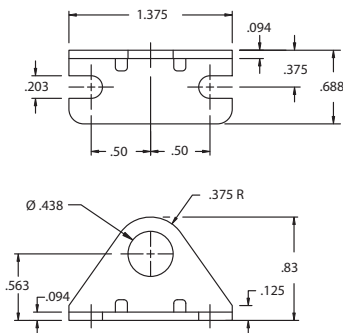

Mounting Bracket
F-M117003
Price: \$1.92

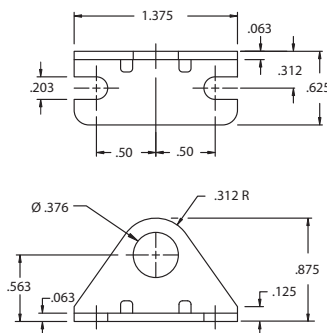

Mounting Bracket
F-M117004
Price: \$1.92

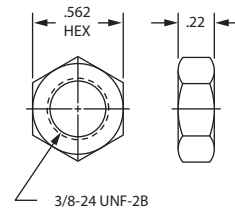

Mounting Nut
F-M190002
Price: \$0.26

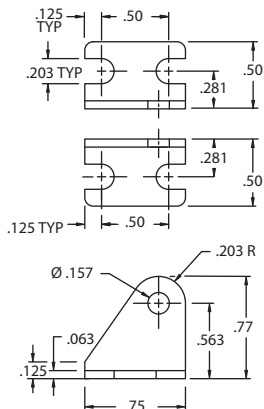

Pivot Bracket
F-M029002
Price: \$3.05

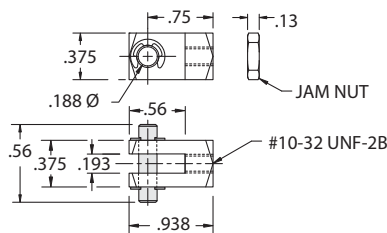

Rod Clevis
F-M127002
Price: \$3.05

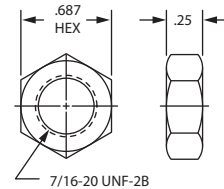

Mounting Nut
F-M190003
Price: \$0.26

9/16" Bore Cylinders

MOUNTING NUT INCLUDED

F-0563S01-00A

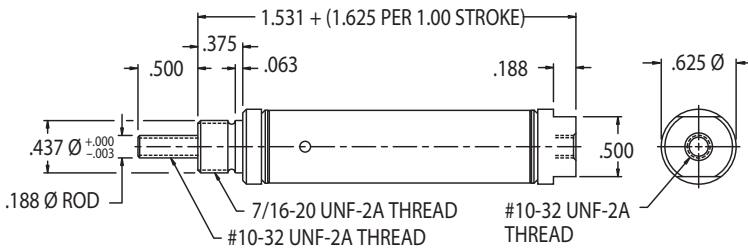

BUMPER OPTION (AVAILABLE AT CAP END ONLY) - ADD .062 TO OAL.. **\$2.84**
 MAGNETIC PISTON - ADD .531 TO OAL..... **\$23.36**
 BOTH BUMPER & MAGNETIC PISTON - ADD .713 TO OAL

\$12.75 Base Price
Add \$2.23 per inch of stroke

Single Acting Spring Return

Front Nose Mount

Standard Stroke Lengths:

1/2", 1", 1-1/2", 2", 2-1/2", 3", 4"

Maximum Stroke: 6"

Optional Accessories:

- F-M117003 Mounting Bracket
- F-M127002 Rod Clevis

Base Weight: .06 lbs.

Plus .05 lbs. per inch of stroke

MOUNTING NUT NOT INCLUDED

F-0563S02-00A

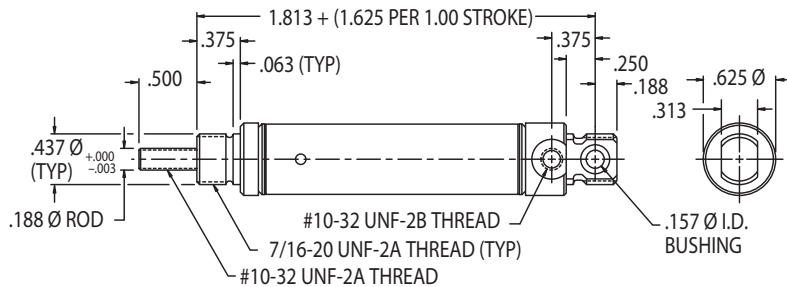

BUMPER OPTION (AVAILABLE AT CAP END ONLY) - ADD .062 TO OAL.. **\$2.84**
 MAGNETIC PISTON - ADD .531 TO OAL..... **\$23.73**
 BOTH BUMPER & MAGNETIC PISTON - ADD .713 TO OAL

\$16.64 Base Price
Add \$2.23 per inch of stroke

Single Acting Spring Return

Double Nose or Rear Pivot Mount

Standard Stroke Lengths:

1/2", 1", 1-1/2", 2", 2-1/2", 3", 4"

Maximum Stroke: 6"

Optional Accessories:

- F-M117003 Mounting Bracket
- F-M129002 Pivot Bracket
- F-M127002 Rod Clevis

Base Weight: .06 lbs.

Plus .05 lbs. per inch of stroke

MOUNTING NUT INCLUDED

F-0563R01-00A

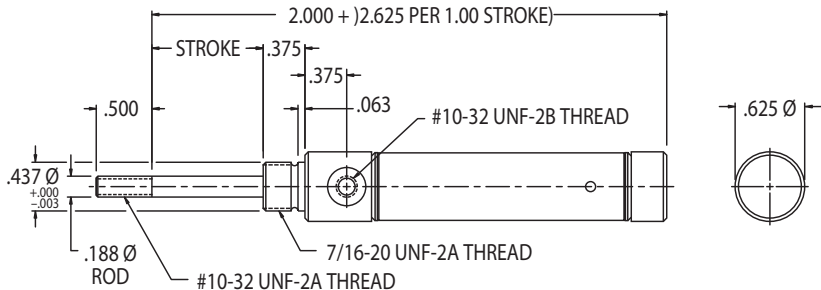

BUMPER OPTION (AVAILABLE AT ROD END ONLY) - ADD .062 TO OAL.. **\$2.84**
 MAGNETIC PISTON - ADD .531 TO OAL..... **\$23.90**
 BOTH BUMPER & MAGNETIC PISTON - ADD .713 TO OAL

\$19.16 Base Price
Add \$2.23 per inch of stroke

Single Acting Spring Extend

Front Nose Mount

Standard Stroke Lengths:

1/2", 1", 1-1/2", 2", 2-1/2", 3"

Maximum Stroke: 6"

Optional Accessories:

- F-M117003 Mounting Bracket
- F-M127002 Rod Clevis

Base Weight: .08 lbs.

Plus .04 lbs. per inch of stroke

MOUNTING NUT NOT INCLUDED

F-0563R02-00A

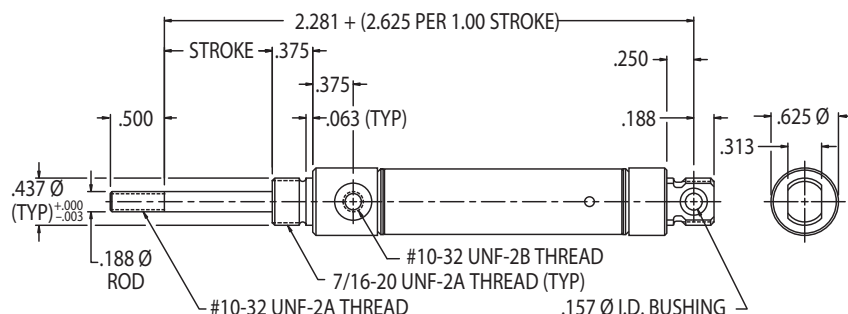

BUMPER OPTION (AVAILABLE AT ROD END ONLY) - ADD .062 TO OAL.. **\$2.84**
 MAGNETIC PISTON - ADD .531 TO OAL..... **\$24.34**
 BOTH BUMPER & MAGNETIC PISTON - ADD .713 TO OAL

\$23.28 Base Price
Add \$2.23 per inch of stroke

Single Acting Spring Extend

Double Nose or Rear Pivot Mount

Standard Stroke Lengths:

1/2", 1", 1-1/2", 2", 2-1/2", 3"

Maximum Stroke: 6"

Optional Accessories:

- F-M117003 Mounting Bracket
- F-M129002 Pivot Bracket
- F-M127002 Rod Clevis

Base Weight: .08 lbs.

Plus .04 lbs. per inch of stroke

F Series

9/16" Bore Cylinders

Single Acting Spring Return
Front Nose Mount

Non-Rotating

Standard Stroke Lengths:

1/2", 1", 1-1/2", 2", 2-1/2", 3", 4"

Maximum Stroke: 6"

Optional Accessories:

- F-M117003 Mounting Bracket
- F-M127002 Rod Clevis

Base Weight: .06 lbs.

Plus .05 lbs. per inch of stroke



F-0563N01-00A

MOUNTING NUT INCLUDED

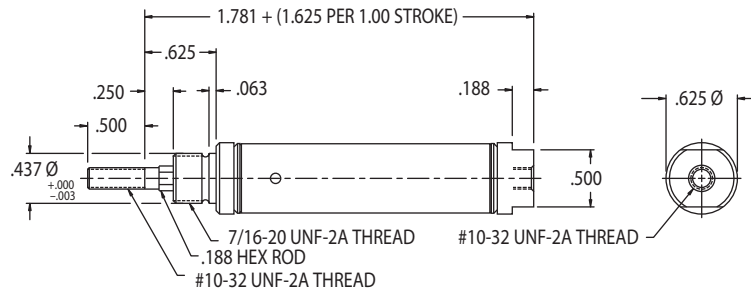

\$15.77 Base Price

Add \$2.23 per inch of stroke

BUMPER OPTION (AVAILABLE CAP END ONLY) - ADD .062 TO OAL..... **\$2.84**
MAGNETIC PISTON - ADD .531 TO OAL..... **\$23.66**
BOTH BUMPER & MAGNETIC PISTON - ADD .713 TO OAL

Single Acting Spring Return
Rear Pivot Mount

Non-Rotating

Standard Stroke Lengths:

1/2", 1", 1-1/2", 2", 2-1/2", 3", 4"

Maximum Stroke: 6"

Optional Accessories:

- F-M117003 Mounting Bracket
- F-M129002 Pivot Bracket
- F-M127002 Rod Clevis

Base Weight: .06 lbs.

Plus .05 lbs. per inch of stroke

F-0563N02-00A

MOUNTING NUT NOT INCLUDED

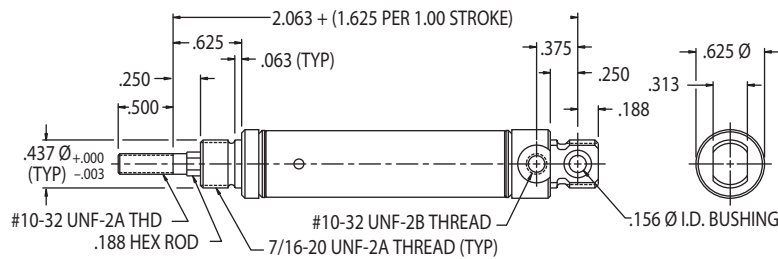

\$19.79 Base Price

Add \$2.23 per inch of stroke

BUMPER OPTION (AVAILABLE CAP END ONLY) - ADD .062 TO OAL..... **\$2.84**
MAGNETIC PISTON - ADD .531 TO OAL..... **\$24.04**
BOTH BUMPER & MAGNETIC PISTON - ADD .713 TO OAL

Double Acting

Front Nose Mount

Standard Stroke Lengths:

1/2", 1", 1-1/2", 2", 2-1/2", 3", 4"

Maximum Stroke: 12"

Optional Accessories:

- F-M117003 Mounting Bracket
- F-M127002 Rod Clevis

Base Weight: .09 lbs.

Plus .02 lbs. per inch of stroke

F-0563D01-00A

MOUNTING NUT INCLUDED

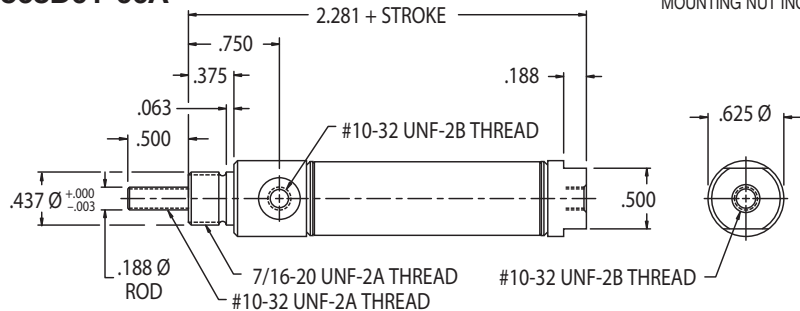

\$17.02 Base Price

Add \$1.60 per inch of stroke

BUMPER OPTION - ADD .125 TO OAL **\$4.20**
MAGNETIC PISTON - ADD .250 TO OAL..... **\$5.92**
BOTH BUMPER & MAGNETIC PISTON - ADD .375 TO OAL

Double Acting

Double Nose or Rear Pivot Mount

Standard Stroke Lengths:

1/2", 1", 1-1/2", 2", 2-1/2", 3", 4"

Maximum Stroke: 12"

Optional Accessories:

- F-M117003 Mounting Bracket
- F-M129002 Pivot Bracket
- F-M127002 Rod Clevis

Base Weight: .09 lbs.

Plus .02 lbs. per inch of stroke

F-0563D02-00A or F-0563D04-00A

MOUNTING NUT NOT INCLUDED - D02
MOUNTING NUTS INCLUDED - D04

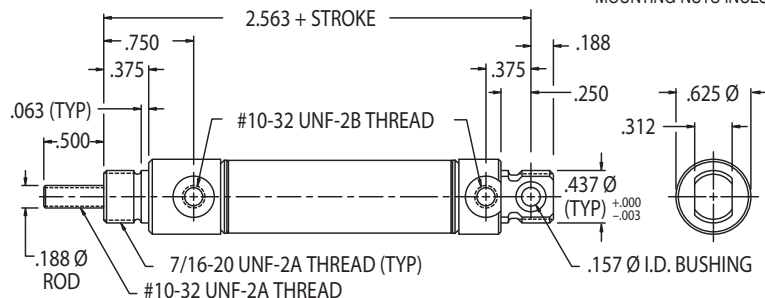

\$20.77 Base Price - D02

\$20.45 Base Price - D04

Includes mounting nuts

Add \$1.60 per inch of stroke

BUMPER OPTION - ADD .125 TO OAL **\$4.20**
MAGNETIC PISTON - ADD .250 TO OAL..... **\$5.86**
BOTH BUMPER & MAGNETIC PISTON - ADD .375 TO OAL

Specifications and prices subject to change without notice or incurring obligation

See pricing notes on Page 5

2-23-10

MOUNTING NUT INCLUDED

F-0563D03-00A

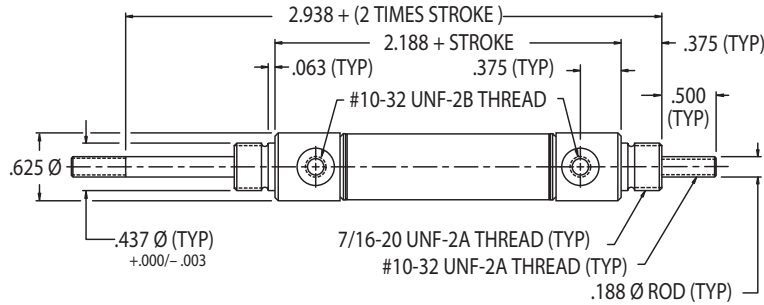

Double Acting

Double Rod

Standard Stroke Lengths:

1/2", 1", 1-1/2", 2", 2-1/2", 3", 4", 5", 6"

Maximum Stroke: 12"

Optional Accessories:

• F-M117003 Mounting Bracket

• F-M127002 Rod Clevis

Base Weight: .16 lbs.

Plus .03 lbs. per inch of stroke

BUMPER OPTION - ADD .125 TO OAL \$2.23

MAGNETIC PISTON - ADD .250 TO OAL..... \$6.23

BOTH BUMPER & MAGNETIC PISTON - ADD .375 TO OAL

\$29.34 Base Price

Add \$2.11 per inch of stroke

9/16" Bore Cylinder Specifications – Options & Accessories

- -10° to +165°F
- Piston Rod: Hex - Ground 303 Stainless Steel
 Round - Ground and Polished 303 Stainless Steel
- Mounting nuts are standard on all nose mount cylinders
- Bumpers are OPTIONAL on all 9/16" bore cylinders
 (except in combination with Viton® option)
- Approximate Force Exerted: (0.25) x (Air Line Pressure)
- Spring Force: 2 lb. Relaxed – 4 lb. Compressed
- Magnetic piston optional on all 9/16" bore cylinders
 (except in combination with Viton® option).

OPTION	PRICE ADDER
• Viton® Seals – Not available with bumpers or magnetic piston	
Spring Return (-15° F to 300° F).....	\$4.20
N01 & N02 Spring Return (-15° F to 300° F).....	\$10.96
Double Acting (-15° F to 350° F).....	\$10.96
Spring Extend (-15° F to 300° F).....	\$7.71
Double Rod (-15° F to 350° F).....	\$15.47
• Ports Rotated – 90° on S02, R02, N02, or D02 (both).....	No charge
• Rod Wiper	\$7.10
• Side Port – Cap end port on S01, N01, or D01.....	No charge
Add .03 to OAL	
• Low Temperature Seals – Applications to -40° F	\$10.88
• Rod Extension	\$0.74/inch
• Rod Thread Extension.....	\$1.79/inch

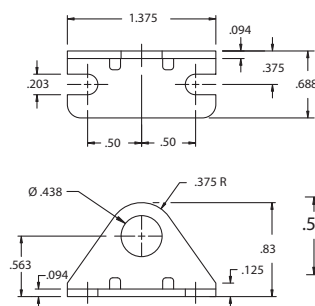

Mounting Bracket

F-M117003

Price: \$1.92

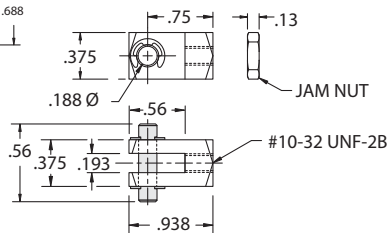

Rod Clevis

F-M127002

Price: \$3.05

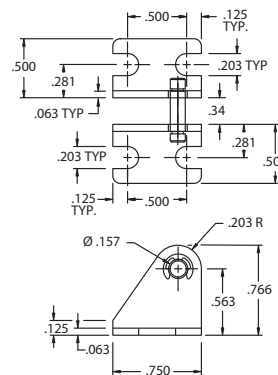

Pivot Bracket

F-M129002

Price: \$5.85

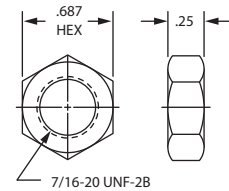

Mounting Nut

F-M190003

Price: \$0.26

F Series

3/4" Bore Cylinders



Single Acting Spring Return Front Nose Mount

Standard Stroke Lengths:
1/2", 1", 1-1/2", 2", 2-1/2", 3", 4"
Maximum Stroke: 6"

- Optional Accessories:
- F-M117006 Mounting Bracket
 - F-M127003 Rod Clevis
- Base Weight: .10 lbs.
Plus .08 lbs. per inch of stroke

F-0750S01-00A

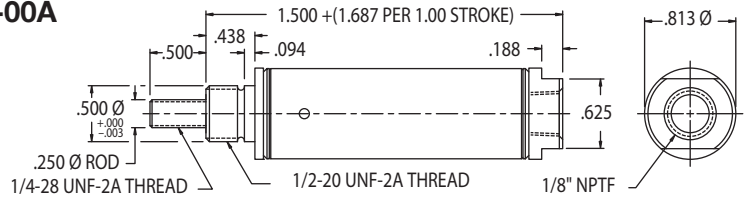

\$13.26 Base Price
Add \$2.23 per inch of stroke

BUMPER OPTION (AVAILABLE CAP END ONLY) - ADD .125 TO OAL **\$2.84**
MAGNETIC PISTON OPTION - ADD .688 TO OAL **\$23.42**
BOTH BUMPER & MAGNETIC PISTON OPTIONS - ADD .890 TO OAL

MOUNTING NUT INCLUDED

Single Acting Spring Return Rear Pivot Mount

Standard Stroke Lengths:
1/2", 1", 1-1/2", 2", 2-1/2", 3", 4"
Maximum Stroke: 6"

- Optional Accessories:
- F-M117006 Mounting Bracket
 - F-M029003 Pivot Bracket
 - F-M127003 Rod Clevis
- Base Weight: .13 lbs.
Plus .08 lbs. per inch of stroke

F-0750S02-00A

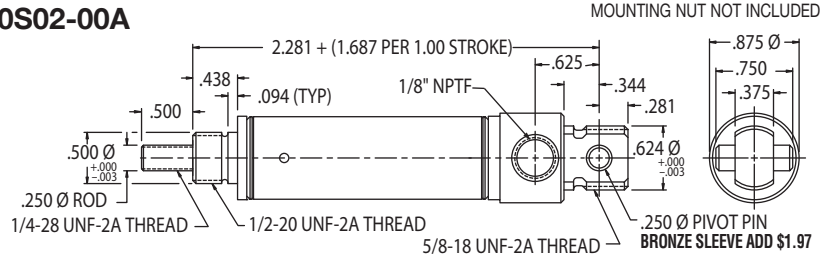

\$17.02 Base Price
Add \$2.23 per inch of stroke

BUMPER OPTION (AVAILABLE CAP END ONLY) - ADD .125 TO OAL **\$2.84**
MAGNETIC PISTON OPTION - ADD .688 TO OAL **\$23.79**
BOTH BUMPER & MAGNETIC PISTON OPTIONS - ADD .890 TO OAL

MOUNTING NUT NOT INCLUDED

Single Acting Spring Extend Front Nose Mount

Standard Stroke Lengths:
1/2", 1", 1-1/2", 2", 2-1/2", 3", 4"
Maximum Stroke: 6"

- Optional Accessories:
- F-M117005 Mounting Bracket
 - F-M127003 Rod Clevis
- Base Weight: .18 lbs.
Plus .07 lbs. per inch of stroke

F-0750R01-00A

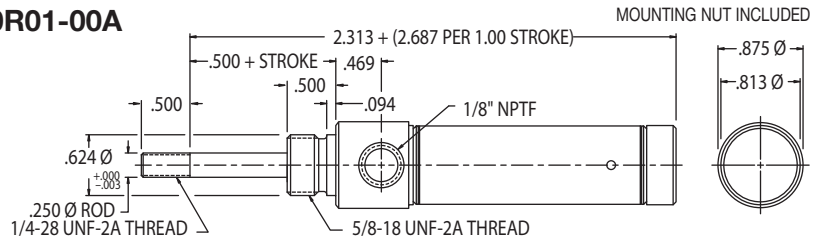

\$19.42 Base Price
Add \$2.23 per inch of stroke

BUMPER OPTION (AVAILABLE ROD END ONLY) - ADD .125 TO OAL **\$2.84**
MAGNETIC PISTON OPTION - ADD .688 TO OAL **\$23.97**
BOTH BUMPER & MAGNETIC PISTON OPTIONS - ADD .890 TO OAL

MOUNTING NUT INCLUDED

Single Acting Spring Extend Rear Pivot Mount

Standard Stroke Lengths:
1/2", 1", 1-1/2", 2", 2-1/2", 3", 4"
Maximum Stroke: 6"

- Optional Accessories:
- F-M117005 Mounting Bracket
 - F-M029003 Pivot Bracket
 - F-M127003 Rod Clevis
- Base Weight: .18 lbs.
Plus .07 lbs. per inch of stroke

F-0750R02-00A

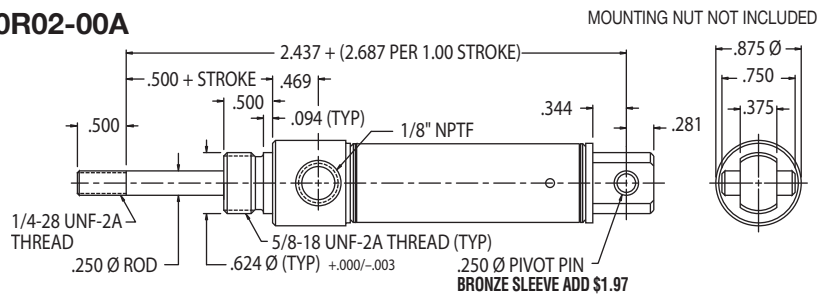

\$23.53 Base Price
Add \$2.23 per inch of stroke

BUMPER OPTION (AVAILABLE ROD END ONLY) - ADD .125 TO OAL **\$2.84**
MAGNETIC PISTON OPTION - ADD .688 TO OAL **\$24.34**
BOTH BUMPER & MAGNETIC PISTON OPTIONS - ADD .890 TO OAL

MOUNTING NUT NOT INCLUDED

Single Acting Spring Return Front Nose Mount

Non-Rotating
Standard Stroke Lengths:
1/2", 1", 1-1/2", 2", 2-1/2", 3", 4"
Maximum Stroke: 6"

- Optional Accessories:
- F-M117006 Mounting Bracket
 - F-M127003 Rod Clevis
- Base Weight: .10 lbs.
Plus .08 lbs. per inch of stroke

F-0750N01-00A

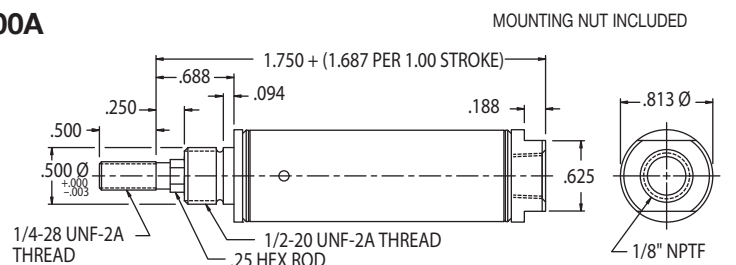

\$16.32 Base Price
Add \$2.23 per inch of stroke

BUMPER OPTION (AVAILABLE CAP END ONLY) - ADD .125 TO OAL **\$2.84**
MAGNETIC PISTON OPTION - ADD .688 TO OAL **\$23.58**
BOTH BUMPER & MAGNETIC PISTON OPTIONS - ADD .890 TO OAL

MOUNTING NUT INCLUDED

F Series 3/4" Bore Cylinders

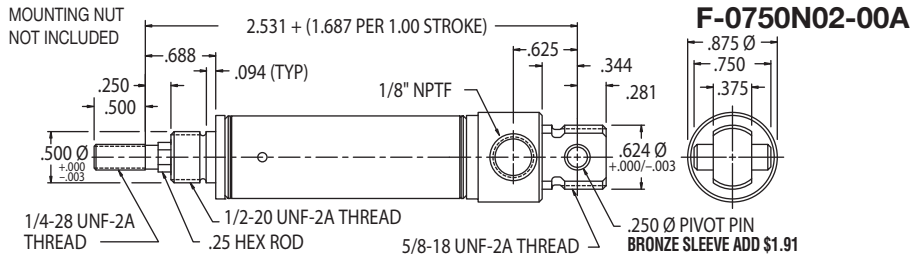

F-0750N02-00A
 BUMPER OPTION (AVAILABLE CAP END ONLY) - ADD .125 TO OAL.....\$2.84
 MAGNETIC PISTON OPTION - ADD .688 TO OAL.....\$24.09
 BOTH BUMPER & MAGNETIC PISTON OPTIONS - ADD .890 TO OAL

\$20.39 Base Price
Add \$2.23 per inch of stroke

Single Acting Spring Return
 Rear Pivot Mount Non-Rotating
 Standard Stroke Lengths:
1/2", 1", 1-1/2", 2", 2-1/2", 3", 4"
 Maximum Stroke: 6"
 Optional Accessories:
 • F-M117006 Mounting Bracket
 • F-M029003 Pivot Bracket
 • F-M127003 Rod Clevis
 Base Weight: .12 lbs.
 Plus .08 lbs. per inch of stroke

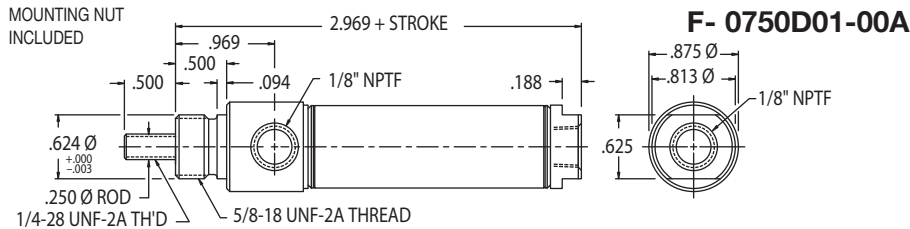

F-0750D01-00A
 BUMPER OPTION - NO CHANGE IN OAL.....\$4.20
 MAGNETIC PISTON OPTION - NO CHANGE IN OAL.....\$6.09
 BOTH BUMPER & MAGNETIC PISTON OPTIONS - ADD .125 TO OAL

\$17.13 Base Price
Add \$1.60 per inch of stroke

Double Acting
 Front Nose Mount
 Standard Stroke Lengths:
1/2", 1", 1-1/2", 2", 2-1/2", 3", 4", 5", 6"
 Maximum Stroke: 12"
 Optional Accessories:
 • F-M117005 Mounting Bracket
 • F-M127003 Rod Clevis
 Base Weight: .21 lbs.
 Plus .03 lbs. per inch of stroke

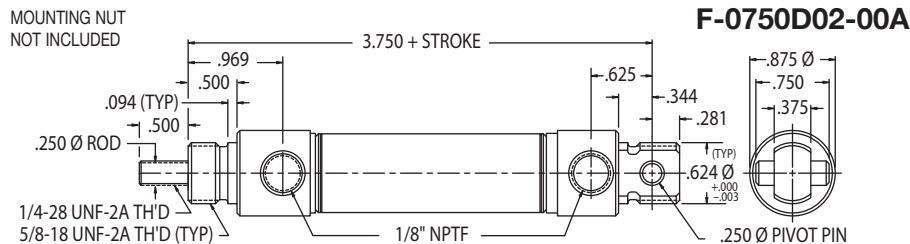

F-0750D02-00A
 BUMPER OPTION - NO CHANGE IN OAL.....\$4.20
 MAGNETIC PISTON OPTION - NO CHANGE IN OAL.....\$6.04
 BOTH BUMPER & MAGNETIC PISTON OPTIONS - ADD .125 TO OAL

\$20.65 Base Price
Add \$1.60 per inch of stroke

Double Acting
 Rear Pivot Mount
 Standard Stroke Lengths:
1/2", 1", 1-1/2", 2", 2-1/2", 3", 4", 5", 6", 7", 8", 9", 10", 11", 12"
 Maximum Stroke: 32"
 Optional Accessories:
 • F-M117005 Mounting Bracket
 • F-M029003 Pivot Bracket
 • F-M127003 Rod Clevis
 Base Weight: .21 lbs.
 Plus .03 lbs. per inch of stroke

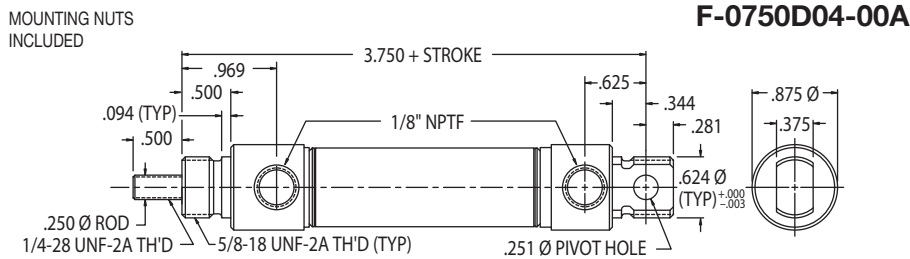

F-0750D04-00A
 BUMPER OPTION - NO CHANGE IN OAL.....\$4.20
 MAGNETIC PISTON OPTION - NO CHANGE IN OAL.....\$6.04
 BOTH BUMPER & MAGNETIC PISTON OPTIONS - ADD .125 TO OAL

\$22.74 Base Price
Add \$1.60 per inch of stroke

Double Acting
 Double Nose or Rear Pivot Mount
 Standard Stroke Lengths
1/2", 1", 1-1/2", 2", 2-1/2", 3", 4", 5", 6", 7", 8", 9", 10", 11", 12"
 Maximum Stroke: 32"
 Optional Accessories:
 • F-M117005 Mounting Bracket
 • F-M129003 Pivot Bracket
 • F-M127003 Rod Clevis
 Base Weight: .29 lbs.
 Plus .03 lbs. per inch of stroke

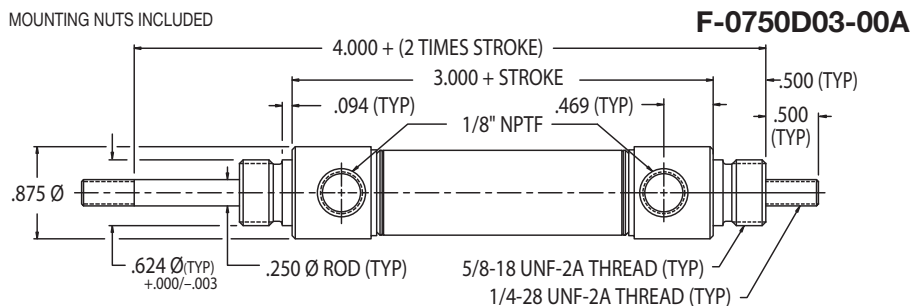

F-0750D03-00A
 BUMPER OPTION - ADD .250 TO OAL.....\$1.85
 MAGNETIC PISTON OPTION - NO CHANGE IN OAL.....\$6.41
 BOTH BUMPER & MAGNETIC PISTON OPTIONS - ADD .250 TO OAL

\$32.47 Base Price
Add \$2.11 per inch of stroke

Double Acting
 Double Rod
 Standard Stroke Lengths:
1/2", 1", 1-1/2", 2", 2-1/2", 3", 4", 5", 6"
 Maximum Stroke: 12"
 Optional Accessories:
 • F-M117005 Mounting Bracket
 • F-M127003 Rod Clevis
 Base Weight: .37 lbs.
 Plus .04 lbs. per inch of stroke

F Series

3/4" Bore Cylinders



Double Acting

Front Block Mount

Standard Stroke Lengths:

1/2", 1", 1-1/2", 2", 2-1/2", 3", 4", 5", 6"

Maximum Stroke: 12"

Optional Accessories:

- F-M127003 Rod Clevis

Base Weight: .22 lbs.

Plus .03 lbs. per inch of stroke

F-0750D05-00A

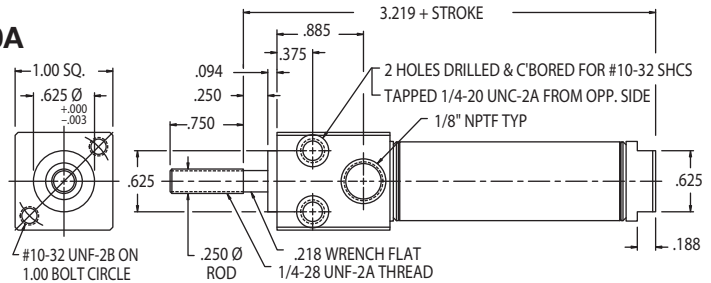

\$27.55 Base Price
Add \$1.60 per inch of stroke

BUMPER OPTION - NO CHANGE IN OAL.....\$4.43
 MAGNETIC PISTON OPTION - NO CHANGE IN OAL.....\$6.46
 BOTH BUMPER & MAGNETIC PISTON OPTIONS - ADD .125 TO OAL

Double Acting

Trunnion Mount

Standard Stroke Lengths:

1/2", 1", 1-1/2", 2", 2-1/2", 3", 4", 5", 6"

Maximum Stroke: 12"

Optional Accessories:

- F-M029006 Trunnion Bracket
- F-M127003 Rod Clevis

Base Weight: .29 lbs.

Plus .03 lbs. per inch of stroke

F-0750D06-00A

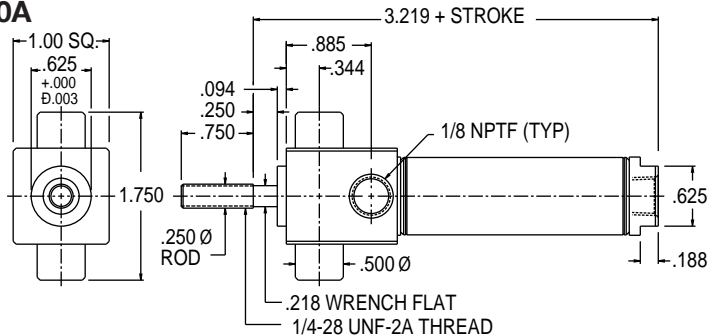

\$35.74 Base Price
Add \$1.60 per inch of stroke

BUMPER OPTION - NO CHANGE IN OAL.....\$4.20
 MAGNETIC PISTON OPTION - NO CHANGE IN OAL.....\$6.09
 BOTH BUMPER & MAGNETIC PISTON OPTIONS - ADD .125 TO OAL

Double Acting

Front Nose Mount

with Adjustable Cushions

Standard Stroke Lengths:

1/2", 1", 1-1/2", 2", 2-1/2", 3", 4", 5", 6"

Maximum Stroke: 12"

Optional Accessories:

- F-M117005 Mounting Bracket
- F-M127003 Rod Clevis

Base Weight: .24 lbs.

Plus .03 lbs. per inch of stroke

F-0750DG1-00A

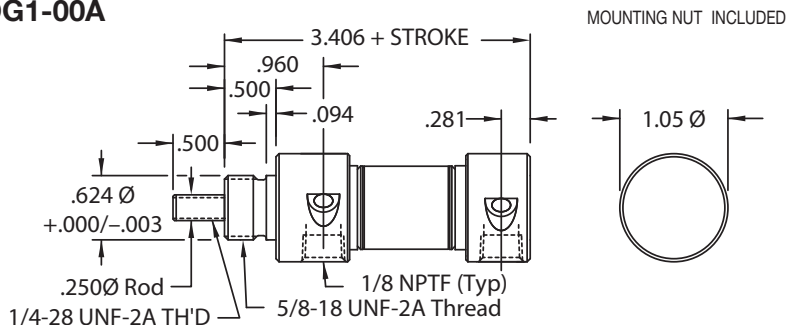

\$35.07 Base Price
Add \$1.60 per inch of stroke
Viton® seals - Consult Factory

MAGNETIC PISTON OPTION - NO CHANGE IN OAL.....\$7.03

Double Acting

Rear Pivot Mount

with Adjustable Cushions

Standard Stroke Lengths:

1/2", 1", 1-1/2", 2", 2-1/2", 3", 4", 5", 6"

Maximum Stroke: 12"

Optional Accessories:

- F-M117005 Mounting Bracket
- F-M029003 Pivot Bracket
- F-M127003 Rod Clevis

Base Weight: .29 lbs.

Plus .03 lbs. per inch of stroke

F-0750DG2-00A or F-0750DG4-00A

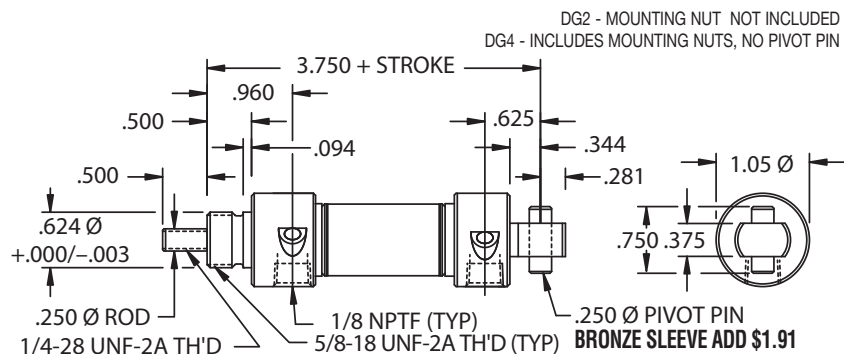

\$41.97 Base Price - DG2
\$41.97 Base Price - DG4 includes mounting nuts, no pin

Add \$1.69 per inch of stroke MAGNETIC PISTON OPTION - NO CHANGE IN OAL.....\$6.46

Viton® seals - Consult Factory

Cylinder Specifications – Options & Accessories

- -10° to +165°F
- Piston Rod:
 Round - Ground, Polished, 303 Stainless Steel
 Hex - Ground 303 Stainless Steel
- Mounting nuts are standard on all nose mount cylinders
- Bronze Rod Guide Bushing is Standard
- Approximate Force Exerted: (0.4) x (Air Line Pressure)
- Spring Force: 3 lb. Relaxed – 6 lb. Compressed
- Magnetic piston optional on all 3/4" bore cylinders (except in combination with Viton® option).

OPTION	PRICE ADDER
• Viton® Seals – Not available with bumpers or magnetic piston	
Spring Return (-15° F to 300° F)	\$4.20
Double Acting (-15° F to 350° F)	\$10.96
Spring Extend (-15° F to 300° F)	\$7.71
Double Rod (-15° F to 350° F)	\$15.41
• Ports Rotated – 90°	
on S02, R02, N02, D02 (both), or D04 (both)	No charge
• Rod Wiper – Not available in spring return models	\$7.10
• Side Port – Cap end port on S01, N01, D01, D05, or D06 (Add .44 to OAL)	No Charge
• Low Temperature Seals – Applications to -40° F	\$4.83
• Rod Extension	\$0.74/inch
• Rod Thread Extension	\$1.79/inch

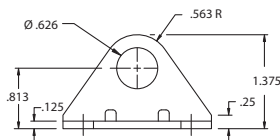
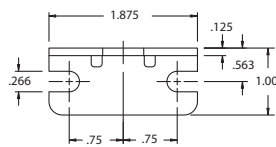

Mounting Bracket
 F-M117005
 Price: \$2.55

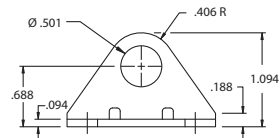
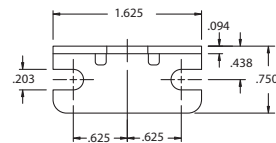

Mounting Bracket
 F-M117006
 Price: \$2.12

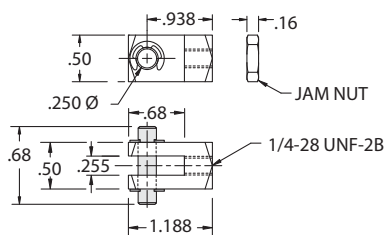

Rod Clevis
 F-M127003
 Price: \$3.51

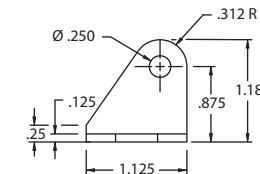
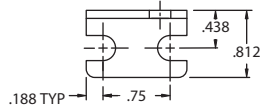
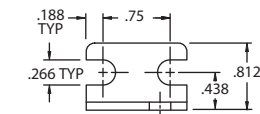

Pivot Bracket
 F-M029003
 \$3.05

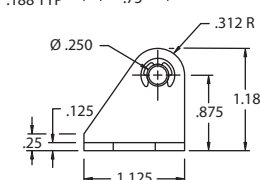
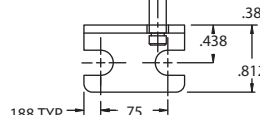
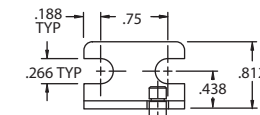

Pivot Bracket
 F-M129003
 Price: \$5.55

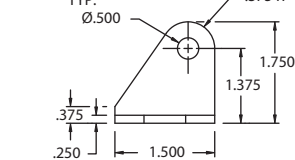
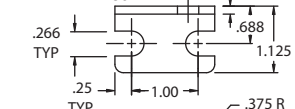
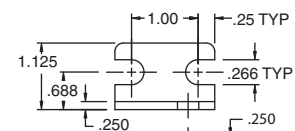

Trunnion Bracket
 F-M029006
 Price: \$13.37

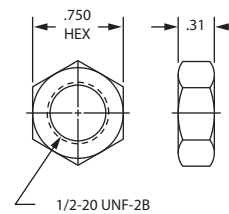

Mounting Nut
 F-M190004
 Price: \$0.39

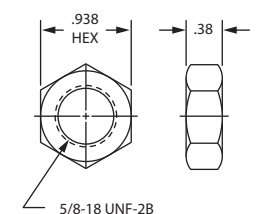

Mounting Nut
 F-M190005
 Price: \$0.39

F Series

7/8" Bore Cylinders



Single Acting Spring Return Front Nose Mount

Standard Stroke Lengths:
1/2", 1", 1-1/2", 2", 2-1/2", 3", 4"
Maximum Stroke: 6"

- Optional Accessories:
- F-M117005 Mounting Bracket
 - F-M127003 Rod Clevis
- Base Weight: .17 lbs.
Plus .09 lbs. per inch of stroke

F-0875S01-00A

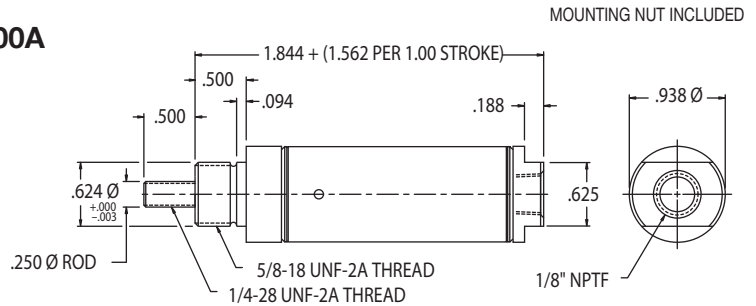

\$13.74 Base Price
Add \$2.46 per inch of stroke

BUMPER OPTION (AVAILABLE CAP END ONLY) - NO CHANGE IN OAL ... \$2.72
MAGNETIC PISTON OPTION - ADD .531 TO OAL \$23.48
BOTH BUMPER & MAGNETIC PISTON OPTIONS - ADD .733 TO OAL

Single Acting Spring Return Rear Pivot Mount

Standard Stroke Lengths:
1/2", 1", 1-1/2", 2", 2-1/2", 3", 4"
Maximum Stroke: 6"

- Optional Accessories:
- F-M117005 Mounting Bracket
 - F-M029003 Pivot Bracket
 - F-M127003 Rod Clevis
- Base Weight: .17 lbs.
Plus .09 lbs. per inch of stroke

F-0875S02-00A

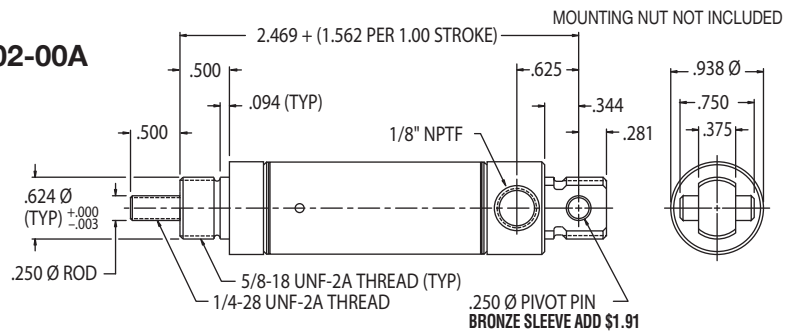

\$17.49 Base Price
Add \$2.46 per inch of stroke

BUMPER OPTION (AVAILABLE CAP END ONLY) - NO CHANGE IN OAL ... \$2.72
MAGNETIC PISTON OPTION - ADD .531 TO OAL \$23.85
BOTH BUMPER & MAGNETIC PISTON OPTIONS - ADD .733 TO OAL

Single Acting Spring Extend Front Nose Mount

Standard Stroke Lengths:
1/2", 1", 1-1/2", 2", 2-1/2", 3", 4"
Maximum Stroke: 6"

- Optional Accessories:
- F-M117005 Mounting Bracket
 - F-M127003 Rod Clevis
- Base Weight: .20 lbs.
Plus .09 lbs. per inch of stroke

F-0875R01-00A

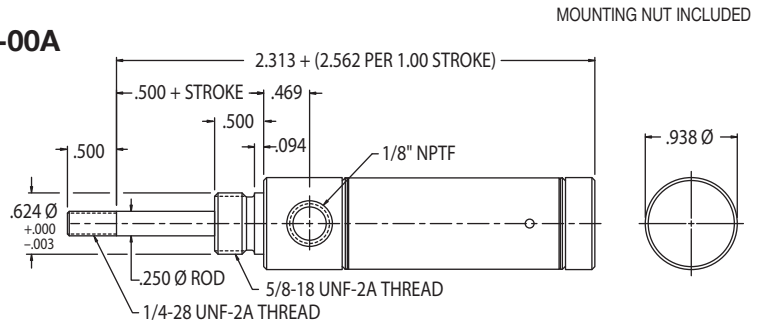

\$20.22 Base Price
Add \$2.46 per inch of stroke

BUMPER OPTION (AVAILABLE ROD END ONLY) - NO CHANGE IN OAL ... \$2.72
MAGNETIC PISTON OPTION - ADD .531 TO OAL \$24.09
BOTH BUMPER & MAGNETIC PISTON OPTIONS - ADD .733 TO OAL

Single Acting Spring Extend Rear Pivot Mount

Standard Stroke Lengths:
1/2", 1", 1-1/2", 2", 2-1/2", 3", 4"
Maximum Stroke: 6"

- Optional Accessories:
- F-M117005 Mounting Bracket
 - F-M029003 Pivot Bracket
 - F-M127003 Rod Clevis
- Base Weight: .20 lbs.
Plus .09 lbs. per inch of stroke

F-0875R02-00A

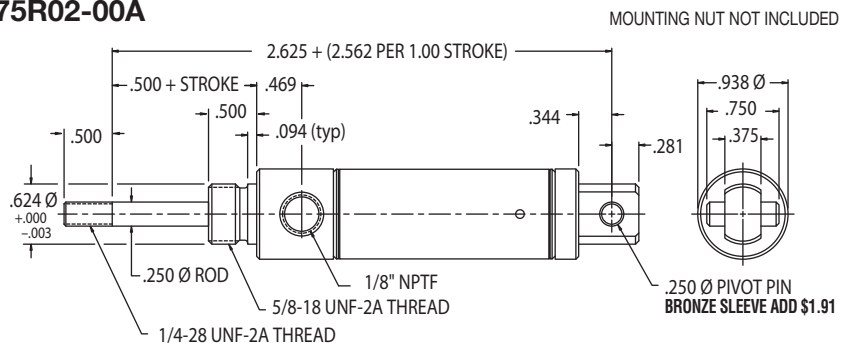

\$23.97 Base Price
Add \$2.46 per inch of stroke

BUMPER OPTION (AVAILABLE ROD END ONLY) - NO CHANGE IN OAL ... \$2.72
MAGNETIC PISTON OPTION - ADD .531 TO OAL \$24.46
BOTH BUMPER & MAGNETIC PISTON OPTIONS - ADD .733 TO OAL

MOUNTING NUT INCLUDED

F-0875N01-00A

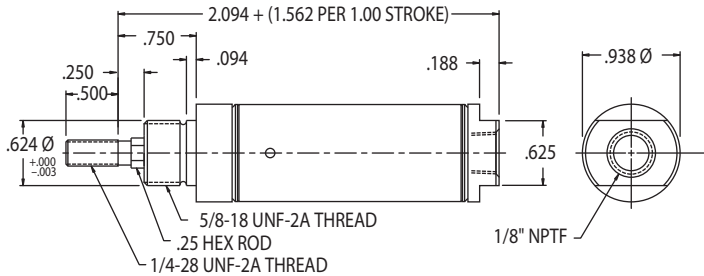

Single Acting Spring Return
Front Nose Mount Non-Rotating
 Standard Stroke Lengths:
1/2", 1", 1-1/2", 2", 2-1/2", 3", 4"
 Maximum Stroke: 6"
 Optional Accessories:
 • F-M117005 Mounting Bracket
 • F-M127003 Rod Clevis
 Base Weight: .17 lbs.
 Plus .09 lbs. per inch of stroke

BUMPER OPTION (AVAILABLE CAP END ONLY) - NO CHANGE IN OAL ... \$3.02
 MAGNETIC PISTON OPTION - ADD .531 TO OAL \$23.73
 BOTH BUMPER & MAGNETIC PISTON OPTIONS - ADD .733 TO OAL

\$16.37 Base Price
Add \$2.46 per inch of stroke

MOUNTING NUT NOT INCLUDED

F-0875N02-00A

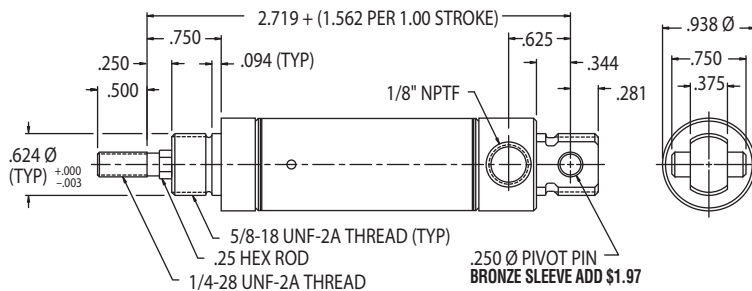

Single Acting Spring Return
Rear Pivot Mount Non-Rotating
 Standard Stroke Lengths:
1/2", 1", 1-1/2", 2", 2-1/2", 3", 4"
 Maximum Stroke: 6"
 Optional Accessories:
 • F-M117005 Mounting Bracket
 • F-M029003 Pivot Bracket
 • F-M127003 Rod Clevis
 Base Weight: .17 lbs.
 Plus .09 lbs. per inch of stroke

BUMPER OPTION (AVAILABLE CAP END ONLY)- NO CHANGE IN OAL..... \$4.01
 MAGNETIC PISTON OPTION - ADD .531 TO OAL \$25.01
 BOTH BUMPER & MAGNETIC PISTON OPTIONS - ADD .733 TO OAL

\$19.53 Base Price
Add \$2.46 per inch of stroke

MOUNTING NUT INCLUDED

F-0875D01-00A

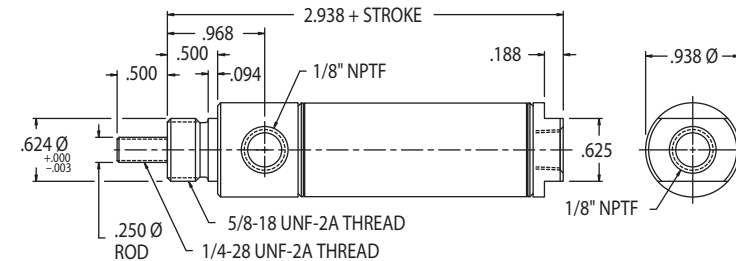

Double Acting
Front Nose Mount
 Standard Stroke Lengths
1/2", 1", 1-1/2", 2", 2-1/2", 3", 4", 5", 6"
 Maximum Stroke: 12"
 Optional Accessories:
 • F-M117005 Mounting Bracket
 • F-M127003 Rod Clevis
 Base Weight: .25 lbs.
 Plus .03 lbs. per inch of stroke

BUMPER OPTION - NO CHANGE IN OAL..... \$3.02
 MAGNETIC PISTON OPTION - NO CHANGE IN OAL..... \$6.09
 BOTH BUMPER & MAGNETIC PISTON OPTIONS - ADD .125 TO OAL

\$19.27 Base Price
Add \$1.60 per inch of stroke

MOUNTING NUT NOT INCLUDED

F-0875D02-00A

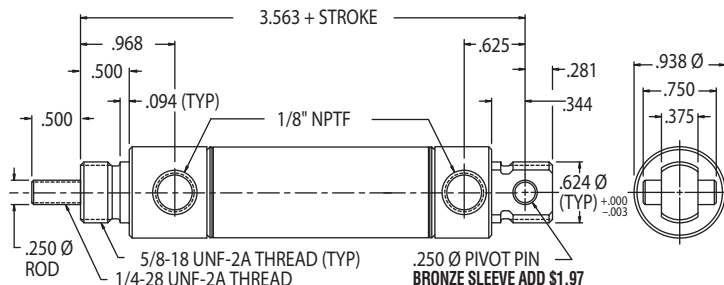

Double Acting
Rear Pivot Mount
 Standard Stroke Lengths:
1/2", 1", 1-1/2", 2", 2-1/2", 3", 4", 5", 6"
 Maximum Stroke: 32"
 Optional Accessories:
 • F-M117005 Mounting Bracket
 • F-M029003 Pivot Bracket
 • F-M127003 Rod Clevis
 Base Weight: .32 lbs.
 Plus .03 lbs. per inch of stroke

BUMPER OPTION - NO CHANGE IN OAL..... \$4.01
 MAGNETIC PISTON OPTION - NO CHANGE IN OAL..... \$6.09
 BOTH BUMPER & MAGNETIC PISTON OPTIONS - ADD .125 TO OAL

\$24.09 Base Price
Add \$1.60 per inch of stroke

F Series

7/8" Bore Cylinders



Double Acting

Double Nose or Rear Pivot Mount

Standard Stroke Lengths:

1/2", 1", 1-1/2", 2", 2-1/2", 3", 4", 5", 6"

Maximum Stroke: 32"

Optional Accessories:

- F-M117005 Mounting Bracket
- F-M129003 Pivot Bracket
- F-M127003 Rod Clevis

Base Weight: .32 lbs.

Plus .03 lbs. per inch of stroke

F-0875D04-00A

MOUNTING NUTS INCLUDED

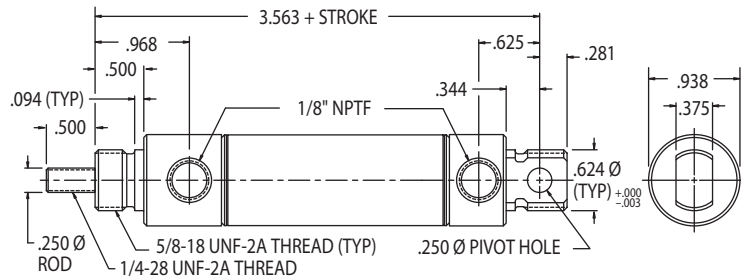

\$25.37 Base Price

Add \$1.60 per inch of stroke

BUMPER OPTION - NO CHANGE IN OAL \$4.01
 MAGNETIC PISTON OPTION - NO CHANGE IN OAL \$6.09
 BOTH BUMPER & MAGNETIC PISTON OPTIONS - ADD .125 TO OAL

7/8" Bore Cylinder Specifications – Options & Accessories

- -10° to +165°F
- Piston Rod:
 Round - Ground and Polished, 303 Stainless Steel
 Hex - Ground 303 Stainless Steel
- Mounting nuts are standard on all nose mount cylinders
- Bronze Rod Guide Bushing is Standard
- Approximate Force Exerted: (0.6) x (Air Line Pressure)
- Spring Force: 3 lb. Relaxed – 6 lb. Compressed
- Magnetic piston optional on all 7/8" bore cylinders (except in combination with Viton® option).

OPTION	PRICE ADDER
• Viton® Seals – Not available with bumpers or magnetic piston	
S01 – Spring Return (-15° F to 300° F).....	\$4.75
S02 – Spring Return (-15° F to 300° F).....	\$4.70
N01 – Spring Return (-15° F to 300° F).....	\$11.16
N02 – Spring Return (-15° F to 300° F).....	\$12.14
D01 – Double Acting (-15° F to 350° F).....	\$11.16
D02 – Double Acting (-15° F to 350° F).....	\$12.14
D03 – Double Acting (-15° F to 350° F).....	\$11.96
D04 – Double Acting (-15° F to 350° F).....	\$12.14
Spring Extend (-15° F to 300° F).....	\$8.14
• Ports Rotated – 90° on S02, R02, N02, D02 (both), or D04 (both).....	No charge
• Rod Wiper – Not available in spring return models.....	\$7.10
• Side Port – Cap end port on S01, N01, or D01.....	No charge
Add .28 to OAL	
• Low Temperature Seals – Applications to -40° F.....	\$4.83
• Rod Extension.....	\$0.74/inch
• Rod Thread Extension.....	\$1.79/inch

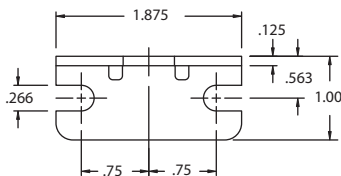

Nose Mounting Bracket

F-M117005

Price: \$2.55

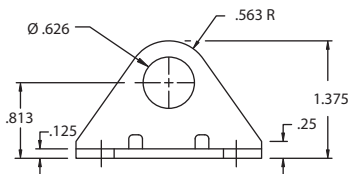

Pivot Mounting Bracket

F-M029003

Price: \$3.05

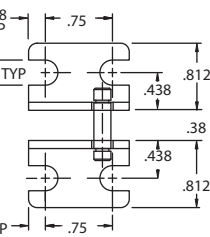
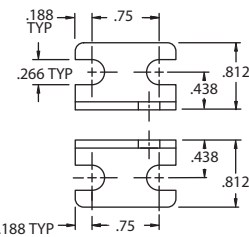

Pivot Bracket

F-M129003

Price: \$5.55

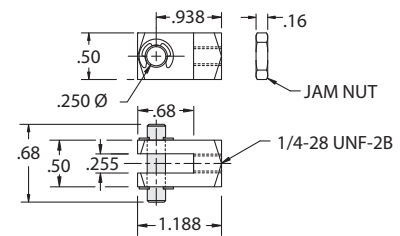

Rod Clevis

F-M127003

Price: \$3.51

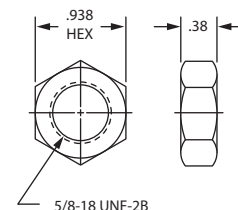

Mounting Nut

F-M190005

Price: \$0.39

1-1/16" Bore Cylinders

MOUNTING NUT INCLUDED

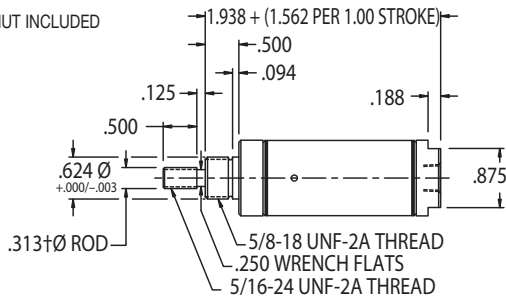

F-1062S01-00A

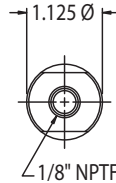

Single Acting Spring Return
Front Nose Mount
 Standard Stroke Lengths:
1/2", 1", 1-1/2", 2", 2-1/2", 3", 4", 5", 6"
 Maximum Stroke: 6"
 Optional Accessories:
 • F-M117005 Mounting Bracket
 • F-M127004 Rod Clevis
 Base Weight: .23 lbs.
 Plus .11 lbs. per inch of stroke

BUMPER OPTION (AVAILABLE CAP END ONLY) - ADD .125 TO OAL..... **\$2.84**
 MAGNETIC PISTON OPTION - ADD .562 TO OAL..... **\$23.48**
 BOTH BUMPER & MAGNETIC PISTON OPTIONS - ADD .765 TO OAL

\$14.91 Base Price
Add \$2.78 per inch of stroke

MOUNTING NUT NOT INCLUDED

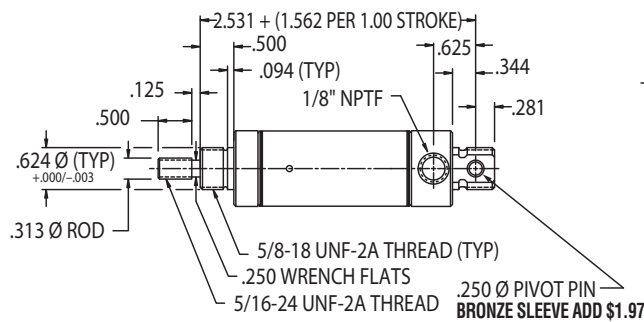

F-1062S02-00A

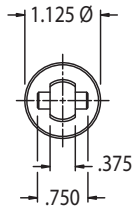

Single Acting Spring Return
Rear Pivot Mount
 Standard Stroke Lengths:
1/2", 1", 1-1/2", 2", 2-1/2", 3", 4"
 Maximum Stroke: 6"
 Optional Accessories:
 • F-M117005 Mounting Bracket
 • F-M029003 Pivot Bracket
 • F-M127004 Rod Clevis
 Base Weight: .24 lbs.
 Plus .11 lbs. per inch of stroke

BUMPER OPTION (AVAILABLE CAP END ONLY) - ADD .125 TO OAL..... **\$2.84**
 MAGNETIC PISTON OPTION - ADD .562 TO OAL..... **\$23.90**
 BOTH BUMPER & MAGNETIC PISTON OPTIONS - ADD .765 TO OAL

\$18.62 Base Price
Add \$2.78 per inch of stroke

MOUNTING NUT INCLUDED

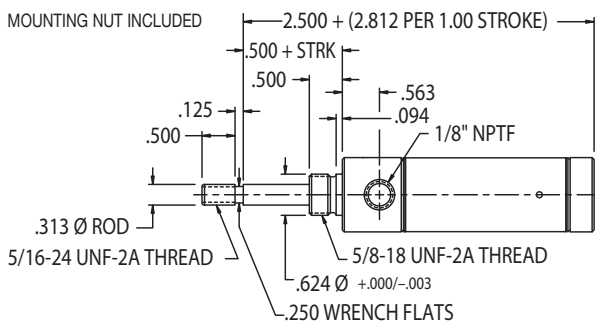

F-1062R01-00A

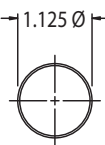

Single Acting Spring Extend
Front Nose Mount
 Standard Stroke Lengths:
1/2", 1", 1-1/2", 2", 2-1/2", 3", 4"
 Maximum Stroke: 6"
 Optional Accessories:
 • F-M117005 Mounting Bracket
 • F-M127004 Rod Clevis
 Base Weight: .24 lbs.
 Plus .16 lbs. per inch of stroke

BUMPER OPTION (AVAILABLE ROD END ONLY) - ADD .125 TO OAL..... **\$2.84**
 MAGNETIC PISTON OPTION - ADD .562 TO OAL..... **\$24.15**
 BOTH BUMPER & MAGNETIC PISTON OPTIONS - ADD .687 TO OAL

\$21.68 Base Price
Add \$2.78 per inch of stroke

MOUNTING NUT NOT INCLUDED

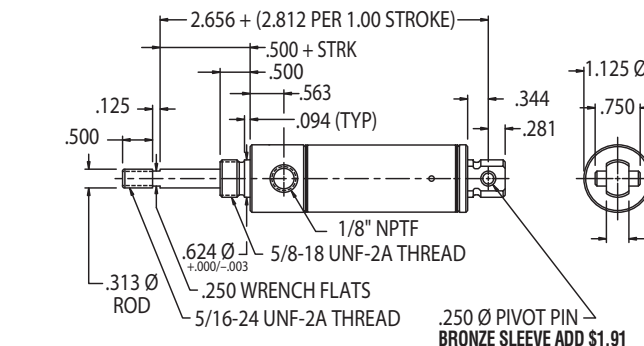

F-1062R02-00A



Single Acting Spring Extend
Rear Pivot Mount
 Standard Stroke Lengths:
1/2", 1", 1-1/2", 2", 2-1/2", 3", 4"
 Maximum Stroke: 6"
 Optional Accessories:
 • F-M117005 Mounting Bracket
 • F-M029003 Pivot Bracket
 • F-M127004 Rod Clevis
 Base Weight: .22 lbs.
 Plus .16 lbs. per inch of stroke

BUMPER OPTION (AVAILABLE ROD END ONLY) - ADD .125 TO OAL..... **\$2.84**
 MAGNETIC PISTON OPTION - ADD .562 TO OAL..... **\$24.53**
 BOTH BUMPER & MAGNETIC PISTON OPTIONS - ADD .765 TO OAL

\$25.81 Base Price
Add \$2.78 per inch of stroke

F Series

1-1/16" Bore Cylinders



Single Acting Spring Return Front Nose Mount Non-Rotating

Standard Stroke Lengths:
1/2", 1", 1-1/2", 2", 2-1/2", 3", 4"
Maximum Stroke: 6"

Optional Accessories:

- F-M117005 Mounting Bracket
- F-M127004 Rod Clevis

Base Weight: .25 lbs.
Plus .12 lbs. per inch of stroke

F-1062N01-00A

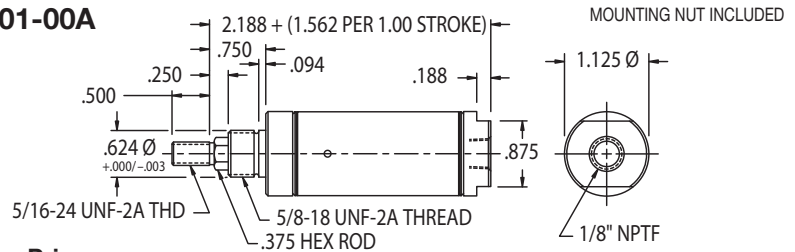

\$17.76 Base Price
Add \$2.78 per inch of stroke

BUMPER OPTION (AVAILABLE CAP END ONLY) - ADD .125 TO OAL.....\$4.20
MAGNETIC PISTON OPTION - ADD .562 TO OAL.....\$23.85
BOTH BUMPER & MAGNETIC PISTON OPTIONS - ADD .765 TO OAL

Single Acting Spring Return Rear Pivot Mount Non-Rotating

Standard Stroke Lengths:
1/2", 1", 1-1/2", 2", 2-1/2", 3", 4"
Maximum Stroke: 6"

Optional Accessories:

- F-M117005 Mounting Bracket
- F-M029003 Pivot Bracket
- F-M127004 Rod Clevis

Base Weight: .25 lbs.
Plus .12 lbs. per inch of stroke

F-1062N02-00A

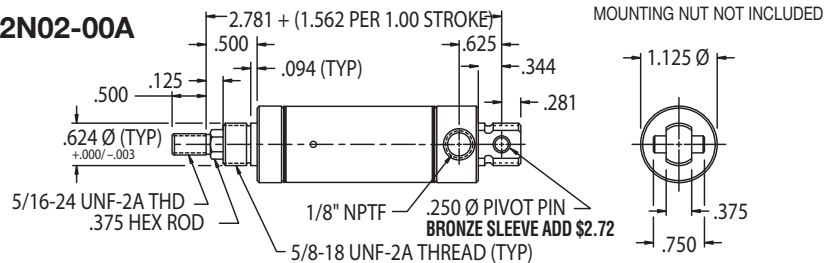

\$21.82 Base Price
Add \$2.78 per inch of stroke

BUMPER OPTION (AVAILABLE CAP END ONLY) - ADD .125 TO OAL.....\$2.84
MAGNETIC PISTON OPTION - ADD .562 TO OAL.....\$24.15
BOTH BUMPER & MAGNETIC PISTON OPTIONS - ADD .765 TO OAL

Double Acting

Front Nose Mount
Standard Stroke Lengths:
1/2", 1", 1-1/2", 2", 2-1/2", 3", 4", 5", 6"
Maximum Stroke: 12"

Optional Accessories:

- F-M117005 Mounting Bracket
- F-M127004 Rod Clevis

Base Weight .33 lbs.
Plus .05 lbs. per inch of stroke

F-1062D01-00A

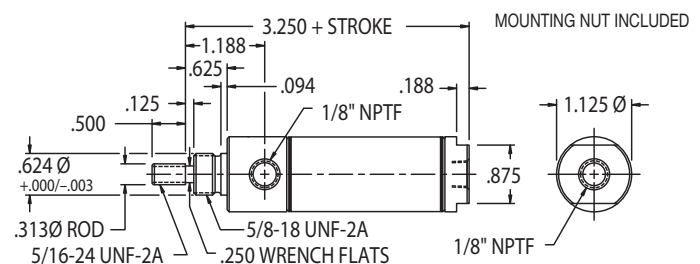

\$19.90 Base Price
Add \$1.60 per inch of stroke

BUMPER OPTION - ADD .125 TO OAL.....\$4.20
MAGNETIC PISTON OPTION - NO CHANGE IN OAL.....\$6.96
BOTH BUMPER & MAGNETIC PISTON OPTIONS - ADD .125 TO OAL

Double Acting

Rear Pivot Mount
Standard Stroke Lengths:
1/2", 1", 1-1/2", 2", 2-1/2", 3", 4",
5", 6", 7", 8", 9", 10", 11", 12"
Maximum Stroke: 32"

Optional Accessories:

- F-M117005 Mounting Bracket
- F-M029003 Pivot Bracket
- F-M127004 Rod Clevis

Base Weight .33 lbs.
Plus .05 lbs. per inch of stroke

F-1062D02-00A

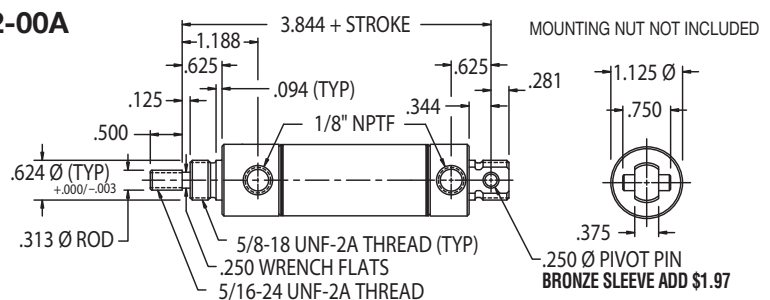

\$23.90 Base Price
Add \$1.60 per inch of stroke

BUMPER OPTION - ADD .125 TO OAL.....\$4.20
MAGNETIC PISTON OPTION - NO CHANGE IN OAL.....\$6.96
BOTH BUMPER & MAGNETIC PISTON OPTIONS - ADD .125 TO OAL

Double Acting

Double Nose or Rear Pivot Mount
Standard Stroke Lengths:
1/2", 1", 1-1/2", 2", 2-1/2", 3", 4",
5", 6", 7", 8", 9", 10", 11", 12"
Maximum Stroke: 32"

Optional Accessories:

- F-M117005 Mounting Bracket
- F-M129003 Pivot Bracket
- F-M127004 Rod Clevis

Base Weight .33 lbs.
Plus .05 lbs. per inch of stroke

F-1062D04-00A

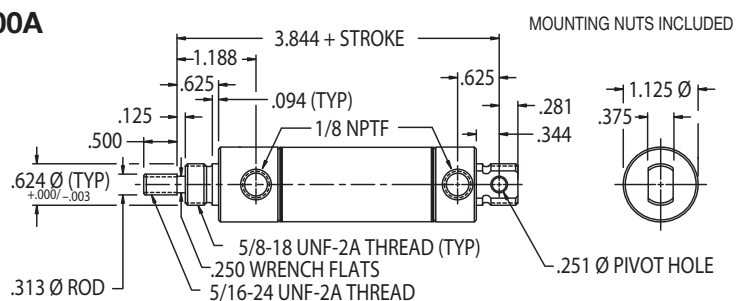

\$26.18 Base Price
Add \$1.60 per inch of stroke

BUMPER OPTION - ADD .125 TO OAL.....\$4.20
MAGNETIC PISTON OPTION - NO CHANGE IN OAL.....\$6.96
BOTH BUMPER & MAGNETIC PISTON OPTIONS - ADD .125 TO OAL

Specifications and prices subject to change without notice or incurring obligation

See pricing notes on Page 5

2-23-10

MOUNTING NUTS INCLUDED

**F-1062D03-00A and F-1062D13-00A
 Interchange Model**

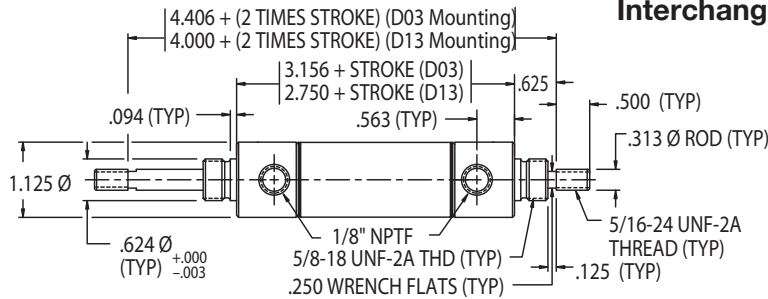

- BUMPER OPTION - ADD .250 TO OAL \$4.20
- D03 - MAGNETIC PISTON OPTION - ADD .000 TO OAL \$6.91
- D13 - MAGNETIC PISTON OPTION - ADD .406 TO OAL \$6.91
- D03 - BOTH BUMPER & MAG. PISTON OPTIONS - ADD .250 TO OAL
- D13 - BOTH BUMPER & MAG. PISTON OPTIONS - ADD .656 TO OAL

\$35.48 Base Price
Add \$2.11 per inch of stroke

Double Acting

Double Rod

Standard Stroke Lengths:

1/2", 1", 1-1/2", 2", 2-1/2", 3", 4", 5", 6"

Maximum Stroke: 12"

Optional Accessories:

- F-M117005 Mounting Bracket
- F-M127004 Rod Clevis

Base Weight: .48 lbs.

Plus .07 lbs. per inch of stroke

MOUNTING NUTS INCLUDED

F-1062DH3-00A

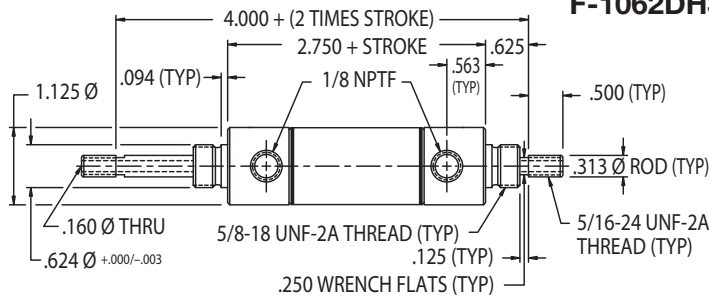

- BUMPER OPTION - ADD .250 TO OAL \$4.20
- MAGNETIC PISTON OPTION - ADD .406 TO OAL \$6.91
- BOTH BUMPER & MAGNETIC PISTON OPTIONS - ADD .656 TO OAL

\$44.87 Base Price
Add \$3.14 per inch of stroke

Double Acting

Hollow Double Rod

Standard Stroke Lengths:

1/2", 1", 1-1/2", 2", 2-1/2", 3", 4", 5", 6"

Maximum Stroke: 12"

Optional Accessories:

- F-M117005 Mounting Bracket
- F-M127004 Rod Clevis

Base Weight: .47 lbs.

Plus .07 lbs. per inch of stroke

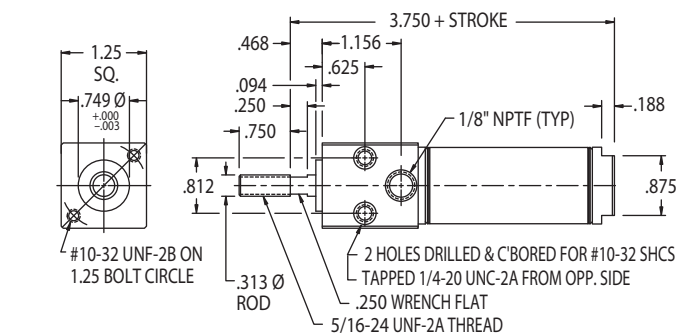

- BUMPER OPTION - ADD .125 TO OAL \$4.43
- MAGNETIC PISTON OPTION - NO CHANGE IN OAL \$6.91
- BOTH BUMPER & MAGNETIC PISTON OPTIONS - ADD .125 TO OAL

\$31.67 Base Price
Add \$1.60 per inch of stroke

Double Acting

Front Block Mount

Standard Stroke Lengths:

1/2", 1", 1-1/2", 2", 2-1/2", 3", 4", 5", 6"

Maximum Stroke: 12"

Optional Accessories:

- F-M127004 Rod Clevis

Base Weight: .49 lbs.

Plus .05 lbs. per inch of stroke

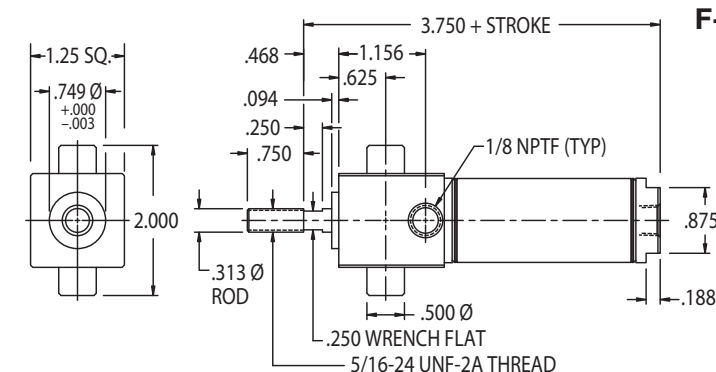

- BUMPER OPTION - ADD .125 TO OAL \$4.20
- MAGNETIC PISTON OPTION - NO CHANGE IN OAL \$6.91
- BOTH BUMPER & MAGNETIC PISTON OPTIONS - ADD .125 TO OAL

\$40.91 Base Price
Add \$1.60 per inch of stroke

Double Acting

Trunnion Mount

Standard Stroke Lengths:

1/2", 1", 1-1/2", 2", 2-1/2", 3", 4", 5", 6"

Maximum Stroke: 12"

Optional Accessories:

- F-M029006 Trunnion Bracket
- F-M127004 Rod Clevis

Base Weight: .49 lbs.

Plus .05 lbs. per inch of stroke

F Series

1-1/16" Bore Cylinders



Double Acting Front Nose Mount with Adjustable Cushions

Standard Stroke Lengths:
1/2", 1", 1-1/2", 2", 2-1/2", 3", 4", 5", 6"
Maximum Stroke: 12"

Optional Accessories:

- F-M117005 Mounting Bracket
- F-M127004 Rod Clevis

Base Weight: .38 lbs.

Plus .04 lbs. per inch of stroke

F-1062DG1-00A

\$42.20 Base Price
Add \$1.60 per inch of stroke
Viton® seals – Consult Factory

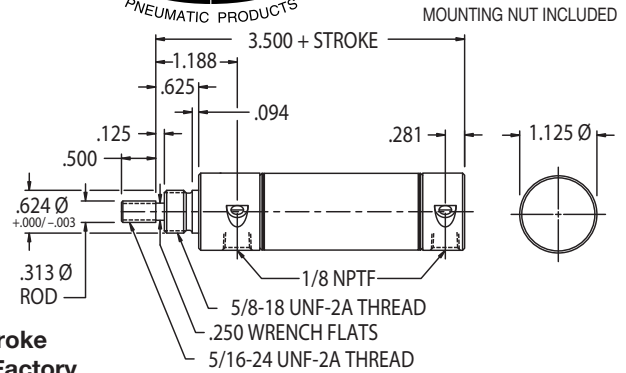

MAGNETIC PISTON - NO CHANGE IN OAL..... \$6.91

Double Acting Rear Pivot Mount with Adjustable Cushions

Standard Stroke Lengths:
1/2", 1", 1-1/2", 2", 2-1/2", 3", 4", 5", 6", 7", 8", 9", 10", 11", 12"
Maximum Stroke: 32"

Optional Accessories:

- F-M117005 Mounting Bracket
- F-M029003 Pivot Bracket
- F-M127004 Rod Clevis

Base Weight: .44 lbs.

Plus .04 lbs. per inch of stroke

F-1062DG2-00A

F-1062DG4-00A

\$49.73 Base Price – DG2
\$51.58 Base Price – DG4 includes mounting nuts, no pin
Add \$1.60 per inch of stroke
Viton® seals – Consult Factory

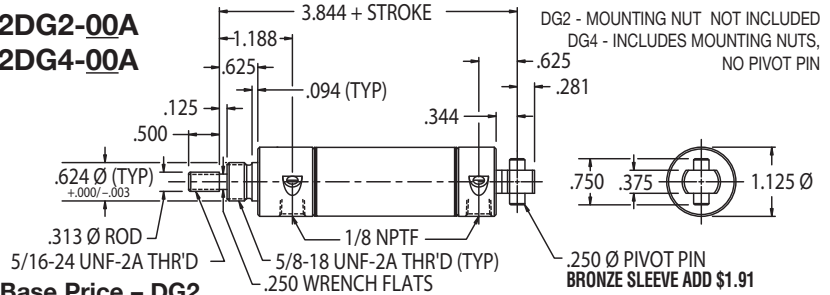

DG2 - MOUNTING NUT NOT INCLUDED
DG4 - INCLUDES MOUNTING NUTS, NO PIVOT PIN
DG2 – MAGNETIC PISTON OPTION - NO CHANGE IN OAL.....\$6.91
DG2 – MAGNETIC PISTON OPTION - NO CHANGE IN OAL.....\$4.81

1-1/16" Bore Cylinder Specifications – Options & Accessories

- -10° to +165°F
- Piston Rod: Hex - Ground 303 Stainless Steel
Round - Ground and Polished, 303 Stainless Steel
- Bronze rod guide bushing is standard.
- Approximate force exerted = (0.9) x (air line pressure).
- Spring force: 3 lbs. relaxed, 6 lbs. compressed.
- Mounting nuts are standard on all nose mount cylinders.
- Bumpers are optional on all 1-1/16" bore cylinders (except in combination with Viton® option).
- Magnetic piston optional on all 1-1/16" bore cylinders (except in combination with Viton® option).

OPTION	PRICE ADDER
• Viton® Seals: Not available with bumpers or magnetic piston	
Spring Return (-15° F to 300° F).....	\$5.36
N01 & N02 Spring Return (-15° F to 300° F).....	\$13.26
Double Acting (-15°F to 350°F).....	\$13.26
D05 – Double Acting (-15°F to 350°F).....	\$12.81
Spring Extend (-15° F to 300° F).....	\$8.63
Double Rod (-15°F to 350°F).....	\$17.76
• Ports Rotated – 90° on S02, R02, N02, D02 (both), or D04 (both).....	No charge
• Rod Wiper – Not available in spring return.....	\$7.10
• Side Port – Cap end port on S01, N01, D01, D05, or D06.....	No charge
Add .25 to OAL	
• Low Temperature Seals (Applications to -40° F).....	\$7.18
• Rod Extension.....	\$0.74/inch
• Rod Thread Extension.....	\$1.79/inch

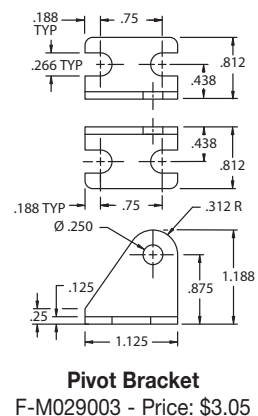
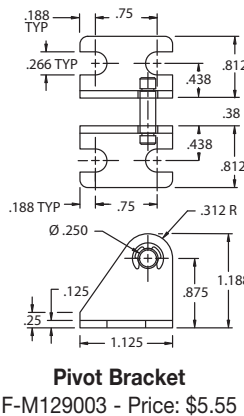
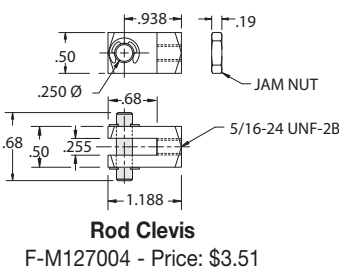
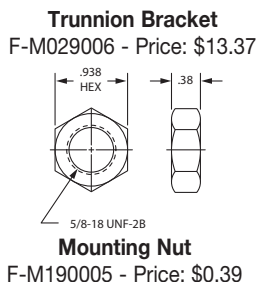
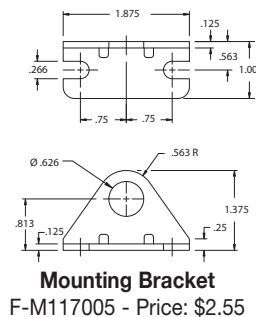
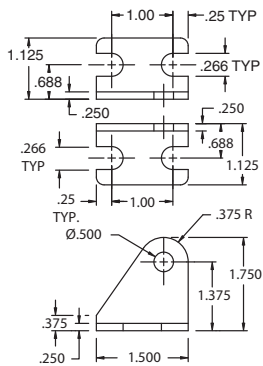

MOUNTING NUT INCLUDED

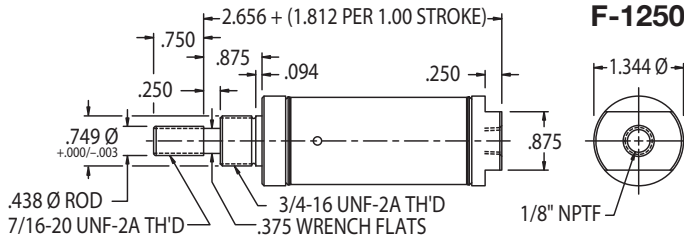

F-1250S01-00A

BUMPER AVAILABLE CAP END ONLY - NO CHANGE IN OAL.....\$4.07
 MAGNETIC PISTON OPTION - ADD .531 TO OAL.....\$24.46
 BOTH BUMPER & MAGNETIC PISTON OPTIONS - ADD .734 TO OAL

\$24.04 Base Price
Add \$3.64 per inch of stroke

F Series 1-1/4" Bore Cylinders

Single Acting Spring Return Front Nose Mount

Standard Stroke Lengths:
 1/2", 1", 1-1/2", 2", 2-1/2", 3", 4"

Maximum Stroke: 6"

Optional Accessories:

- F-M117007 Mounting Bracket
- F-M127005 Rod Clevis

Base Weight: .39 lbs.

Plus .21 lbs. per inch of stroke

MOUNTING NUT NOT INCLUDED

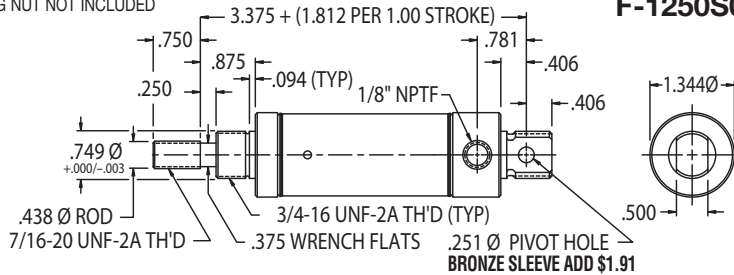

F-1250S02-00A

BUMPER AVAILABLE CAP END ONLY - NO CHANGE IN OAL.....\$4.01
 MAGNETIC PISTON OPTION - ADD .531 TO OAL.....\$24.96
 BOTH BUMPER & MAGNETIC PISTON OPTIONS - ADD .734 TO OAL

\$29.70 Base Price
Add \$3.64 per inch of stroke

Single Acting Spring Return Double Nose or Rear Pivot Mount

Standard Stroke Lengths:
 1/2", 1", 1-1/2", 2", 2-1/2", 3", 4"

Maximum Stroke: 6"

Optional Accessories:

- F-M117007 Mounting Bracket
- F-M229003 Pivot Bracket
- F-M127005 Rod Clevis

Base Weight: .53 lbs.

Plus .21 lbs. per inch of stroke

MOUNTING NUT INCLUDED

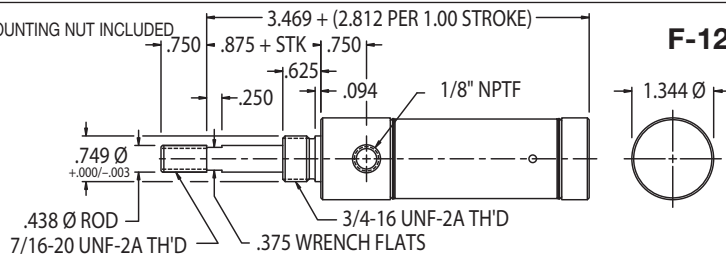

F-1250R01-00A

BUMPER AVAILABLE ROD END ONLY - NO CHANGE IN OAL.....\$4.01
 MAGNETIC PISTON OPTION - ADD .531 TO OAL.....\$24.96
 BOTH BUMPER & MAGNETIC PISTON OPTIONS - ADD .734 TO OAL

\$31.55 Base Price
Add \$3.64 per inch of stroke

Single Acting Spring Extend Front Nose Mount

Standard Stroke Lengths:
 1/2", 1", 1-1/2", 2", 2-1/2", 3", 4"

Maximum Stroke: 6"

Optional Accessories:

- F-M117007 Mounting Bracket
- F-M127005 Rod Clevis

Base Weight: .50 lbs.

Plus .21 lbs. per inch of stroke

MOUNTING NUT NOT INCLUDED

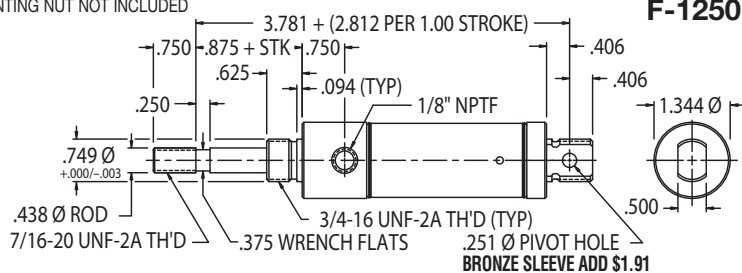

F-1250R02-00A

BUMPER AVAILABLE ROD END ONLY - NO CHANGE IN OAL.....\$4.01
 MAGNETIC PISTON OPTION - ADD .531 TO OAL.....\$25.37
 BOTH BUMPER & MAGNETIC PISTON OPTIONS - ADD .734 TO OAL

\$33.85 Base Price
Add \$3.64 per inch of stroke

Single Acting Spring Extend Double Nose or Rear Pivot Mount

Standard Stroke Lengths:
 1/2", 1", 1-1/2", 2", 2-1/2", 3", 4"

Maximum Stroke: 6"

Optional Accessories:

- F-M117007 Mounting Bracket
- F-M229003 Pivot Bracket
- F-M127005 Rod Clevis

Base Weight: .57 lbs.

Plus .21 lbs. per inch of stroke

MOUNTING NUT INCLUDED

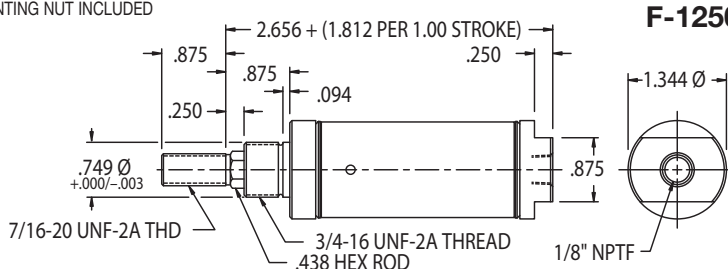

F-1250N01-00A

BUMPER AVAILABLE CAP END ONLY - NO CHANGE IN OAL.....\$4.01
 MAGNETIC PISTON OPTION - ADD .531 TO OAL.....\$24.70
 BOTH BUMPER & MAGNETIC PISTON OPTIONS - ADD .734 TO OAL

\$25.68 Base Price
Add \$3.64 per inch of stroke

Single Acting Spring Return Front Nose Mount Non-Rotating

Standard Stroke Lengths:
 1/2", 1", 1-1/2", 2", 2-1/2", 3", 4"

Maximum Stroke: 6"

Optional Accessories:

- F-M117007 Mounting Bracket
- F-M127005 Rod Clevis

Base Weight: .41 lbs.

Plus .20 lbs. per inch of stroke

F Series

1-1/4" Bore Cylinders



**Single Acting Spring Return
Rear Pivot Mount**

Non-Rotating

Standard Stroke Lengths:

1/2", 1", 1-1/2", 2", 2-1/2", 3", 4"

Maximum Stroke: 6"

Optional Accessories:

- F-M117007 Mounting Bracket
- F-M229003 Pivot Bracket
- F-M127005 Rod Clevis

Base Weight: .41 lbs.

Plus .20 lbs. per inch of stroke

F-1250N02-00A

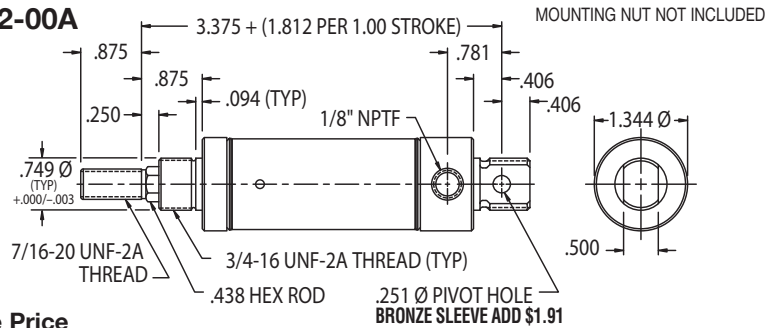

\$32.17 Base Price

Add \$3.64 per inch of stroke

MOUNTING NUT NOT INCLUDED
BUMPER OPTION (AVAILABLE CAP END ONLY) - NO CHANGE IN OAL .. \$4.07
MAGNETIC PISTON OPTION - ADD .531 TO OAL \$25.32
BOTH BUMPER & MAGNETIC PISTON OPTIONS - ADD .734 TO OAL

Double Acting

Front Nose Mount

Standard Stroke Lengths:

1/2", 1", 1-1/2", 2", 2-1/2", 3", 4",

5", 6", 7", 8", 9", 10", 11", 12"

Maximum Stroke: 12"

Optional Accessories:

- F-M117007 Mounting Bracket
- F-M127005 Rod Clevis

Base Weight: .58 lbs.

Plus .08 lbs. per inch of stroke

F-1250D01-00A

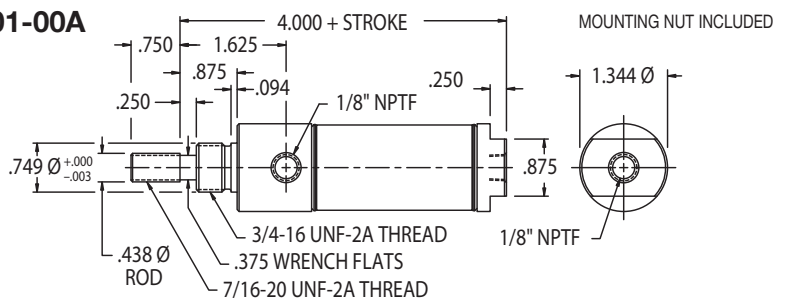

\$30.68 Base Price

Add \$2.11 per inch of stroke

MOUNTING NUT INCLUDED
BUMPER OPTION - NO CHANGE IN OAL \$4.92
MAGNETIC PISTON OPTION - NO CHANGE IN OAL \$7.71
BOTH BUMPER & MAGNETIC PISTON OPTIONS - ADD .125 TO OAL

Double Acting

Double Nose or Rear Pivot Mount

Standard Stroke Lengths:

1/2", 1", 1-1/2", 2", 2-1/2", 3", 4",

5", 6", 7", 8", 9", 10", 11", 12"

Maximum Stroke: 32"

Optional Accessories:

- F-M117007 Mounting Bracket
- F-M229003 Pivot Bracket
- F-M127005 Rod Clevis

Base Weight: .71 lbs.

Plus .08 lbs. per inch of stroke

F-1250D02-00A or F-1250D04-00A

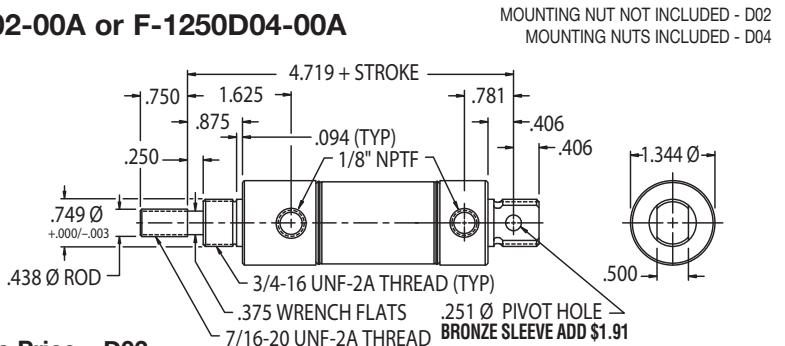

\$36.60 Base Price - D02

\$36.10 Base Price - D04 includes mounting nuts

Add \$2.11 per inch of stroke

MOUNTING NUT NOT INCLUDED - D02
MOUNTING NUTS INCLUDED - D04
BUMPER OPTION - NO CHANGE IN OAL \$4.92
MAGNETIC PISTON OPTION - NO CHANGE IN OAL \$7.71
BOTH BUMPER & MAGNETIC PISTON OPTIONS - ADD .125 TO OAL

Double Acting

Double Rod

Standard Stroke Lengths:

1/2", 1", 1-1/2", 2", 2-1/2", 3", 4", 5", 6"

Maximum Stroke: 12"

Optional Accessories:

- F-M117007 Mounting Bracket
- F-M127005 Rod Clevis

Base Weight: .98 lbs.

Plus .12 lbs. per inch of stroke

F-1250D03-00A

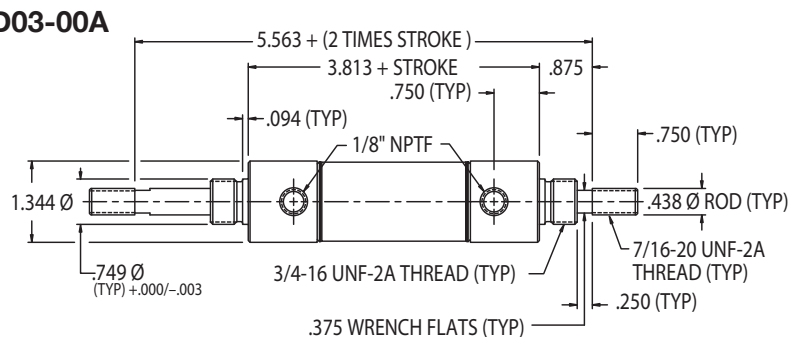

\$52.80 Base Price

Add \$3.14 per inch of stroke

BUMPER OPTION - ADD .250 TO OAL \$1.48
MAGNETIC PISTON OPTION - NO CHANGE IN OAL \$8.02
BOTH BUMPER & MAGNETIC PISTON OPTIONS - ADD .250 TO OAL

MOUNTING NUT INCLUDED

F-1250DH3-00A

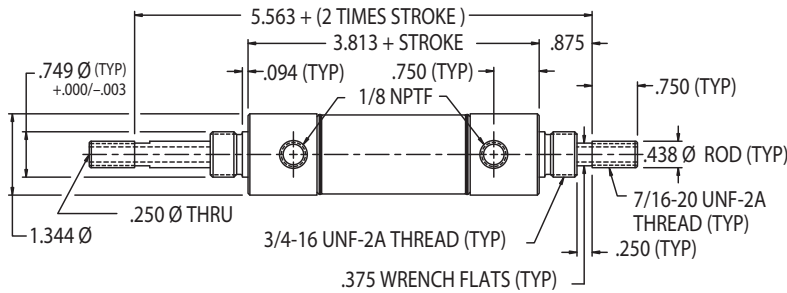

Double Acting

Hollow Double Rod

Standard Stroke Lengths:

1/2", 1", 1-1/2", 2", 2-1/2", 3", 4", 5", 6"

Maximum Stroke: 12"

Optional Accessories:

• F-M117007 Mounting Bracket

Base Weight: .97 lbs.

Plus .12 lbs. per inch of stroke

BUMPER OPTION - ADD .250 TO OAL.....\$4.92
 MAGNETIC PISTON OPTION - NO CHANGE IN OAL.....\$6.72
 BOTH BUMPER & MAGNETIC PISTON OPTIONS - ADD .250 TO OAL

\$57.60 Base Price

Add \$3.40 per inch of stroke

1-1/4" Bore Cylinder Specifications – Options & Accessories

- -10° to +165°F
- Piston Rod:
 Round – Ground and Polished, 303 Stainless Steel.
 Hex – Ground 303 Stainless Steel.
- Bronze rod guide bushing is standard.
- Approximate force exerted = (1.2) x (air line pressure).
- Spring force: 7.5 lbs. relaxed, 15 lbs. compressed.
- Mounting nuts are standard on all nose mount cylinders.
- Bumpers are optional on all 1-1/4" bore cylinders (except in combination with Viton® option).
- Magnetic piston optional on all 1-1/4" bore cylinders (except in combination with Viton® option).

OPTION	Price Adder
• Viton® Seals – Not available with Bumpers or Magnetic Piston	
S01 – Spring Return (-15°F to 300°F).....	\$5.49
S02 – Spring Return (-15°F to 300°F).....	\$5.44
N01 & N02 – Spring Return (-15°F to 300°F).....	\$13.37
Double Acting (-15°F to 350°F).....	\$13.37
R01 – Spring Extend (-15°F to 300°F).....	\$8.70
R02 – Spring Extend (-15°F to 300°F).....	\$8.63
Double Rod (-15°F to 350°F).....	\$19.84
• Ports Rotated – 90° on S02, R02, N02, or D02 (both).....	No charge
• Rod Wiper – Not available in spring return models.....	\$7.10
• Side Port - Cap end port on S01, N01, or D01 Add .31 to OAL.....	No charge
• Low Temperature Seals – Applications to -40° F.....	\$7.18
• Rod Extension -	\$0.99/inch
• Rod Thread Extension.....	\$2.03/inch

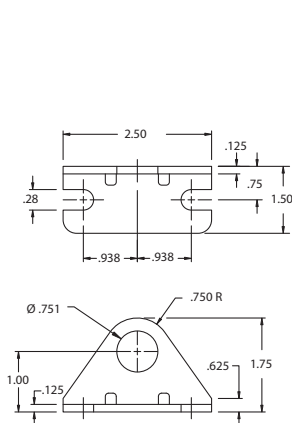

Mounting Bracket
 F-M117007
 Price: \$3.57

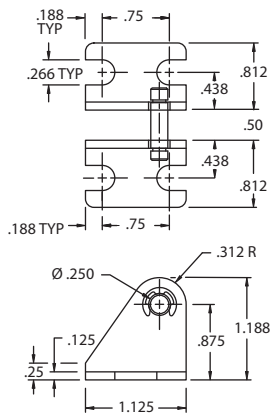

Pivot Bracket
 F-M229003
 Price: \$6.64

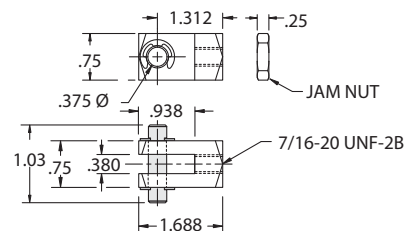

Rod Clevis
 F-M127005
 Price: \$5.80

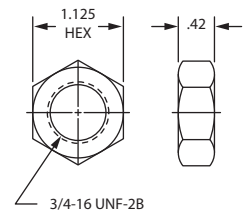

Mounting Nut
 F-M190006
 Price: \$0.51

F Series

1-1/2" Bore Cylinders



Single Acting Spring Return

Front Nose Mount

Standard Stroke Lengths:

1/2", 1", 1-1/2", 2", 2-1/2", 3", 4"

Maximum Stroke: 6"

Optional Accessories:

- F-M117007 Mounting Bracket
- F-M127005 Rod Clevis

Base Weight: .44 lbs.

Plus .22 lbs. per inch of stroke

F-1500S01-00A

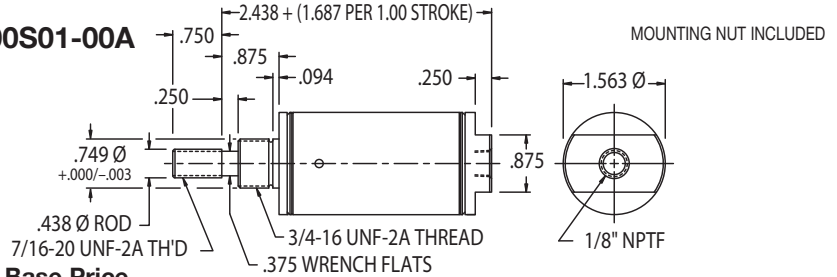

\$27.42 Base Price

Add \$4.20 per inch of stroke

BUMPER AVAILABLE CAP END ONLY - NO CHANGE IN OAL \$4.20
 MAGNETIC PISTON OPTION - ADD .438 TO OAL \$24.85
 BOTH BUMPER & MAGNETIC PISTON OPTIONS - ADD .765 TO OAL

Single Acting Spring Return

Rear Pivot Mount

Standard Stroke Lengths:

1/2", 1", 1-1/2", 2", 2-1/2", 3", 4"

Maximum Stroke: 6"

Optional Accessories:

- F-M117007 Mounting Bracket
- F-M029004 Pivot Bracket
- F-M127005 Rod Clevis

Base Weight: .45 lbs.

Plus .22 lbs. per inch of stroke

F-1500S02-00A

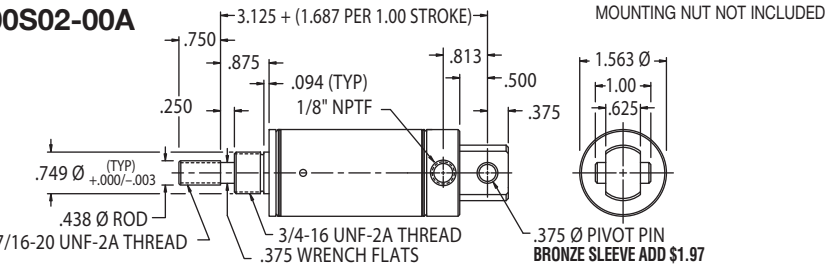

\$32.17 Base Price

Add \$4.20 per inch of stroke

BUMPER AVAILABLE CAP END ONLY - NO CHANGE IN OAL \$4.20
 MAGNETIC PISTON OPTION - ADD .438 TO OAL \$25.37
 BOTH BUMPER & MAGNETIC PISTON OPTIONS - ADD .765 TO OAL

Single Acting Spring Extend

Front Nose Mount

Standard Stroke Lengths:

1/2", 1", 1-1/2", 2", 2-1/2", 3", 4"

Maximum Stroke: 6"

Optional Accessories:

- F-M117007 Mounting Bracket
- F-M127005 Rod Clevis

Base Weight: .44 lbs.

Plus .22 lbs. per inch of stroke

F-1500R01-00A

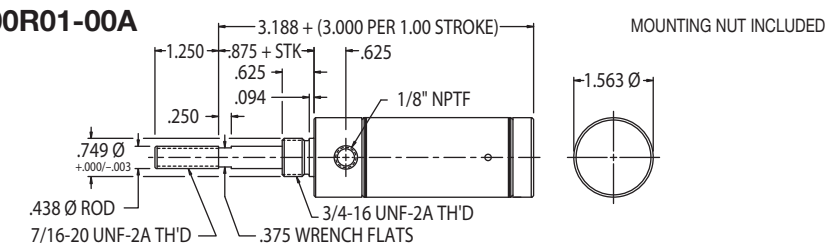

\$33.95 Base Price

Add \$4.20 per inch of stroke

BUMPER AVAILABLE ROD END ONLY - NO CHANGE IN OAL \$4.20
 MAGNETIC PISTON OPTION - ADD .500 TO OAL \$25.53
 BOTH BUMPER & MAGNETIC PISTON OPTIONS - ADD .827 TO OAL

Single Acting Spring Extend

Rear Pivot Mount

Standard Stroke Lengths:

1/2", 1", 1-1/2", 2", 2-1/2", 3", 4"

Maximum Stroke: 6"

Optional Accessories:

- F-M117007 Mounting Bracket
- F-M029004 Pivot Bracket
- F-M127005 Rod Clevis

Base Weight: .45 lbs.

Plus .22 lbs. per inch of stroke

F-1500R02-00A

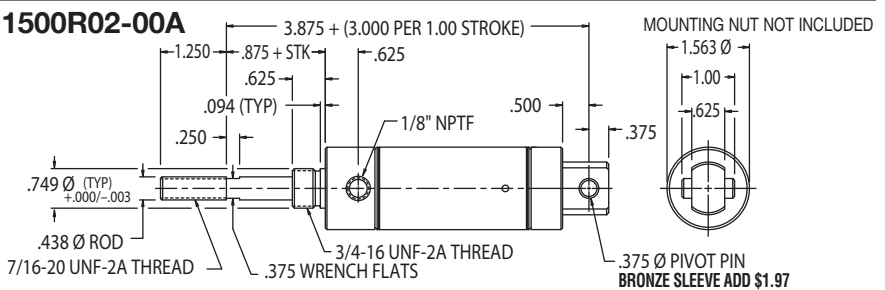

\$38.57 Base Price

Add \$4.20 per inch of stroke

BUMPER AVAILABLE ROD END ONLY - NO CHANGE IN OAL \$4.20
 MAGNETIC PISTON OPTION - ADD .438 TO OAL \$26.07
 BOTH BUMPER & MAGNETIC PISTON OPTIONS - ADD .765 TO OAL

Single Acting Spring Return

Front Nose Mount

Non-Rotating

Standard Stroke Lengths:

1/2", 1", 1-1/2", 2", 2-1/2", 3", 4"

Maximum Stroke: 6"

Optional Accessories:

- F-M117007 Mounting Bracket
- F-M127005 Rod Clevis

Base Weight: .45 lbs.

Plus .22 lbs. per inch of stroke

F-1500N01-00A

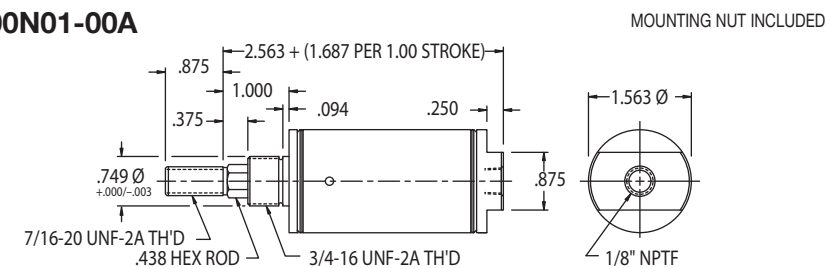

\$30.13 Base Price

Add \$4.20 per inch of stroke

BUMPER AVAILABLE CAP END ONLY - NO CHANGE IN OAL \$4.20
 MAGNETIC PISTON OPTION - ADD .438 TO OAL \$25.21
 BOTH BUMPER & MAGNETIC PISTON OPTIONS - ADD .750 TO OAL

1-1/2" Bore Cylinders

MOUNTING NUT NOT INCLUDED

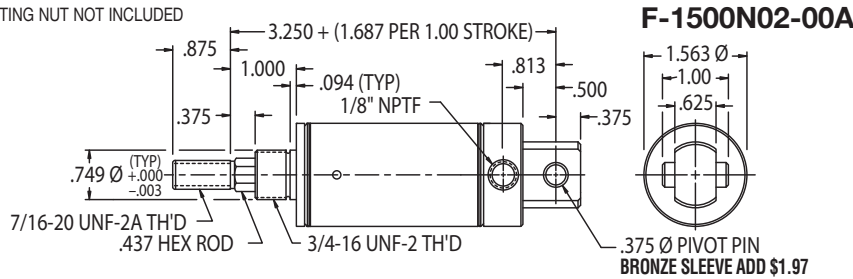

BUMPER AVAILABLE CAP END ONLY - NO CHANGE IN OAL.....\$5.13
 MAGNETIC PISTON OPTION - ADD .438 TO OAL.....\$25.63
 BOTH BUMPER & MAGNETIC PISTON OPTIONS - ADD .765 TO OAL

\$34.68 Base Price
Add \$4.20 per inch of stroke

Single Acting Spring Return
Rear Pivot Mount Non-Rotating
 Standard Stroke Lengths:
1/2", 1", 1-1/2", 2", 2-1/2", 3", 4"
 Maximum Stroke: 6"
 Optional Accessories:
 • F-M117007 Mounting Bracket
 • F-M029004 Pivot Bracket
 • F-M127005 Rod Clevis
 Base Weight: .46 lbs.
 Plus .22 lbs. per inch of stroke

MOUNTING NUT INCLUDED

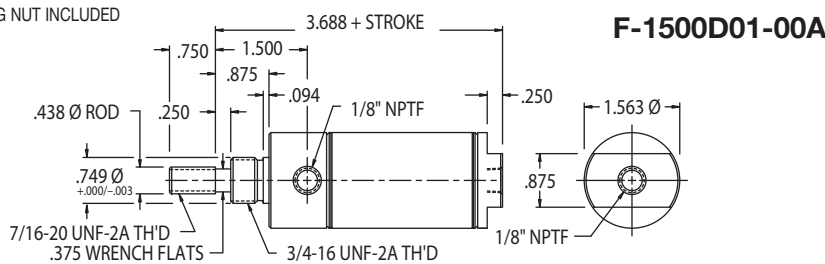

BUMPER OPTION - ADD .125 TO OAL.....\$5.13
 MAGNETIC PISTON OPTION - NO CHANGE IN OAL.....\$7.71
 BOTH BUMPER & MAGNETIC PISTON OPTIONS - ADD .250 TO OAL

\$33.27 Base Price
Add \$2.46 per inch of stroke

Double Acting
Front Nose Mount
 Standard Stroke Lengths:
1/2", 1", 1-1/2", 2", 2-1/2", 3", 4", 5", 6", 7", 8", 9", 10", 11", 12"
 Maximum Stroke: 12"
 Optional Accessories:
 • F-M117007 Mounting Bracket
 • F-M127005 Rod Clevis
 Base Weight: .69 lbs.
 Plus .08 lbs. per inch of stroke

MOUNTING NUT NOT INCLUDED

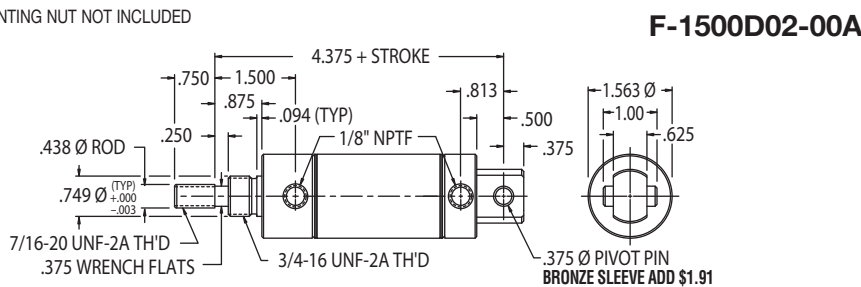

BUMPER OPTION - ADD .125 TO OAL.....\$5.13
 MAGNETIC PISTON OPTION - NO CHANGE IN OAL.....\$7.71
 BOTH BUMPER & MAGNETIC PISTON OPTIONS - ADD .250 TO OAL

\$38.14 Base Price
Add \$2.46 per inch of stroke

Double Acting
Rear Pivot Mount
 Standard Stroke Lengths:
1/2", 1", 1-1/2", 2", 2-1/2", 3", 4", 5", 6", 7", 8", 9", 10", 11", 12"
 Maximum Stroke: 32"
 Optional Accessories:
 • F-M117007 Mounting Bracket
 • F-M029004 Pivot Bracket
 • F-M127005 Rod Clevis
 Base Weight: .73 lbs.
 Plus .08 lbs. per inch of stroke

MOUNTING NUT INCLUDED

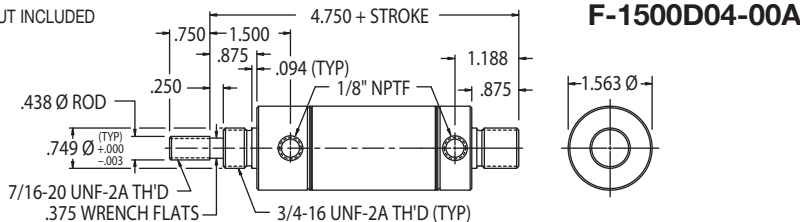

BUMPER OPTION - ADD .125 TO OAL.....\$5.13
 MAGNETIC PISTON OPTION - NO CHANGE IN OAL.....\$7.71
 BOTH BUMPER & MAGNETIC PISTON OPTIONS - ADD .250 TO OAL

\$40.55 Base Price
Add \$2.46 per inch of stroke

Double Acting
Double Nose Mount
 Standard Stroke Lengths:
1/2", 1", 1-1/2", 2", 2-1/2", 3", 4", 5", 6", 7", 8", 9", 10", 11", 12"
 Maximum Stroke: 32"
 Optional Accessories:
 • F-M117007 Mounting Bracket
 • F-M127005 Rod Clevis
 Base Weight: .82 lbs.
 Plus .08 lbs. per inch of stroke

MOUNTING NUTS INCLUDED

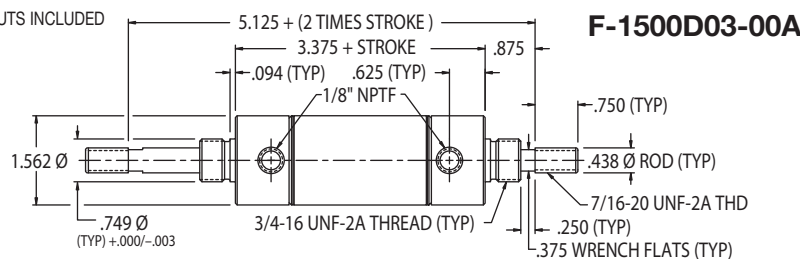

BUMPER OPTION - ADD .250 TO OAL.....\$3.26
 MAGNETIC PISTON OPTION - NO CHANGE IN OAL.....\$8.39
 BOTH BUMPER & MAGNETIC PISTON OPTIONS - ADD .250 TO OAL

\$53.67 Base Price
Add \$4.07 per inch of stroke

Double Acting
Double Rod
 Standard Stroke Lengths:
1/2", 1", 1-1/2", 2", 2-1/2", 3", 4", 5", 6"
 Maximum Stroke: 12"
 Optional Accessories:
 • F-M117007 Mounting Bracket
 • F-M127005 Rod Clevis
 Base Weight: 1.17 lbs.
 Plus .13 lbs. per inch of stroke

F Series

1-1/2" Bore Cylinders



Double Acting

Hollow Double Rod

Standard Stroke Lengths:

1/2", 1", 1-1/2", 2", 2-1/2", 3", 4", 5", 6"

Maximum Stroke: 12"

Optional Accessories:

- F-M117007 Mounting Bracket
- F-M127005 Rod Clevis

Base Weight: 1.16 lbs.

Plus .13 lbs. per inch of stroke

F-1500DH3-00A

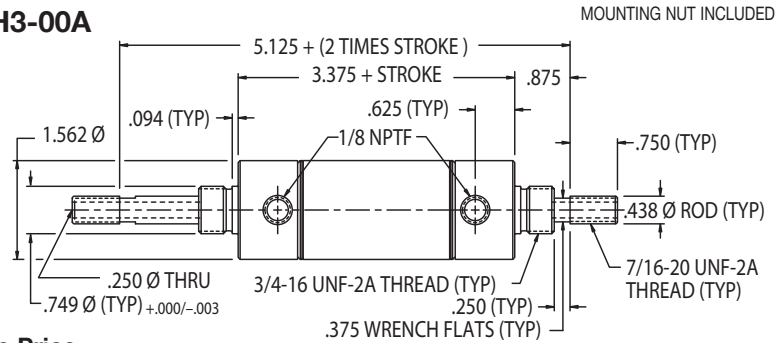

MOUNTING NUT INCLUDED

\$61.85 Base Price

Add \$4.32 per inch of stroke

BUMPER OPTION - ADD .250 TO OAL.....\$3.26
 MAGNETIC PISTON OPTION - NO CHANGE IN OAL.....\$8.44
 BOTH BUMPER & MAGNETIC PISTON OPTIONS - ADD .250 TO OAL

Double Acting

Front Block Mount

Standard Stroke Lengths:

1/2", 1", 1-1/2", 2", 2-1/2", 3", 4", 5", 6"

Maximum Stroke: 12"

Optional Accessories:

- F-M127005 Rod Clevis

Base Weight: .99 lbs.

Plus .08 lbs. per inch of stroke

F-1500D05-00A

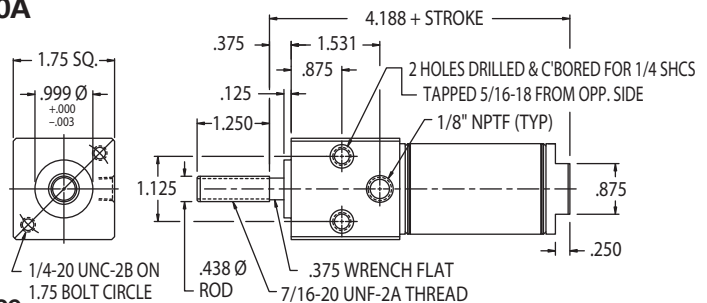

\$52.12 Base Price

Add \$2.46 per inch of stroke

BUMPER OPTION - ADD .125 TO OAL.....\$5.44
 MAGNETIC PISTON OPTION - NO CHANGE IN OAL.....\$8.39
 BOTH BUMPER & MAGNETIC PISTON OPTIONS - ADD .250 TO OAL

Double Acting

Trunnion Mount

Standard Stroke Lengths:

1/2", 1", 1-1/2", 2", 2-1/2", 3", 4", 5", 6"

Maximum Stroke: 12"

Optional Accessories:

- F-M029006 Trunnion Bracket
- F-M127005 Rod Clevis

Base Weight: 1.06 lbs.

Plus .08 lbs. per inch of stroke

F-1500D06-00A

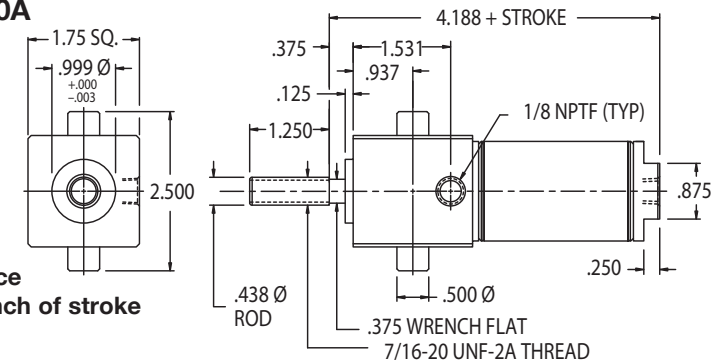

\$64.44 Base Price

Add \$2.60 per inch of stroke

BUMPER OPTION - ADD .125 TO OAL.....\$5.13
 MAGNETIC PISTON OPTION - NO CHANGE IN OAL.....\$2.84
 BOTH BUMPER & MAGNETIC PISTON OPTIONS - ADD .250 TO OAL

Double Acting Front Nose Mount F-1500DG1-00A

with Adjustable Cushions

Standard Stroke Lengths:

1/2", 1", 1-1/2", 2", 2-1/2", 3", 4",

5", 6", 7", 8", 9", 10", 11", 12"

Maximum Stroke: 12"

Optional Accessories:

- F-M117007 Mounting Bracket
- F-M127005 Rod Clevis

Base Weight: .76 lbs.

Plus .09 lbs. per inch of stroke

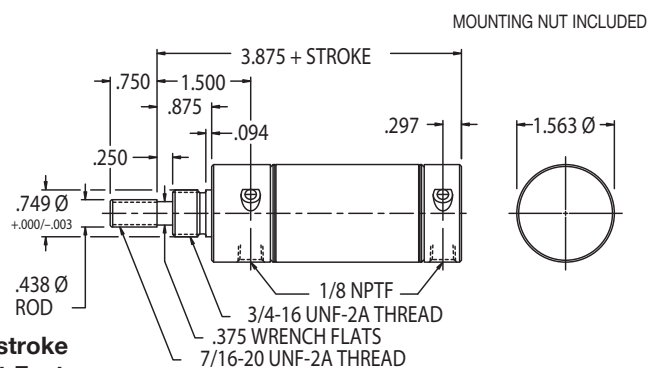

MOUNTING NUT INCLUDED

\$62.72 Base Price

Add \$2.46 per inch of stroke

Viton® Seals – Consult Factory

MAGNETIC PISTON OPTION - NO CHANGE IN OAL.....\$7.71

MOUNTING NUT NOT INCLUDED

F-1500DG2-00A

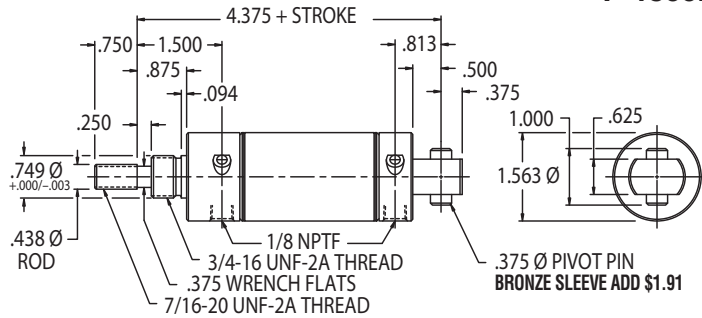

Double Acting
Rear Pivot Mount
with Adjustable Cushions
 Standard Stroke Lengths:
1/2", 1", 1-1/2", 2", 2-1/2", 3", 4",
 5", 6", 7", 8", 9", 10", 11", 12"
 Maximum Stroke: 32"
 Optional Accessories:
 • F-M117007 Mounting Bracket
 • F-M029004 Pivot Bracket
 • F-M127005 Rod Clevis
 Base Weight: .77 lbs.
 Plus .09 lbs. per inch of stroke

MAGNETIC PISTON OPTION - NO CHANGE IN OAL\$7.71

\$68.57 Base Price

Add \$2.46 per inch of stroke

Viton® Seals – Consult Factory

1-1/2" Bore Cylinder Specifications – Options & Accessories

- -10° to +165° F
- Piston Rod: Hex – Ground 303 Stainless Steel.
 Round – Ground and Polished, 303 Stainless Steel.
- Bronze rod guide bushing is standard.
- Approximate force exerted = (1.7) x (air line pressure).
- Spring force: 7 lbs. relaxed, 14 lbs. compressed.
- Mounting nuts are standard on all nose mount cylinders.
- Bumpers are optional on all 1-1/2" bore cylinders (except in combination with Viton® option).
- Magnetic piston optional on all 1-1/2" bore cylinders (except in combination with Viton® option).

OPTION	PRICE ADDER
• Viton® Seals – Not available with bumpers or magnetic piston	
S01 & N01 – Spring Return (-15° F to 300° F).....	\$7.27
S02 – Spring Return (-15° F to 300° F).....	\$7.32
N02 – Spring Return (-15° F to 300° F).....	\$18.11
Double Acting (-15° F to 350° F).....	\$18.11
D06 – Double Acting (-15° F to 350° F).....	\$13.49
R01 – Spring Extend (-15° F to 300° F).....	\$13.56
R02 – Spring Extend (-15° F to 300° F).....	\$13.63
Double Rod (-15° F to 350° F).....	\$19.22
• Ports Rotated – 90° on S02, R02, N02, or D02 (both)	No charge
• Rod Wiper – Not available in spring return models.....	\$7.10
• Side Port – Cap end port on S01, N01, D01, D05, or D06 (Add .19 to OAL)	No charge
• Low Temperature Seals – Applications to -40° F.....	\$8.07
• Rod Extension.....	\$1.17/inch
• Rod Thread Extension.....	\$2.23/inch

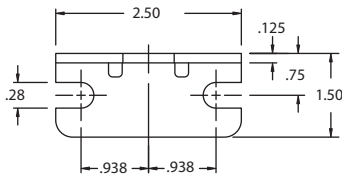

Mounting Bracket
 F-M117007
 Price: \$3.57

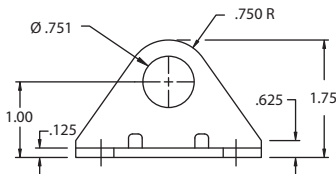

Rod Clevis
 F-M127005
 Price: \$5.80

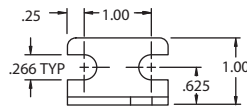

Pivot Bracket
 F-M029004
 Price: \$5.24

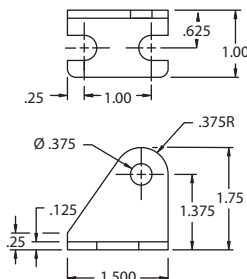

Trunnion Bracket
 F-M029006
 Price: \$13.37

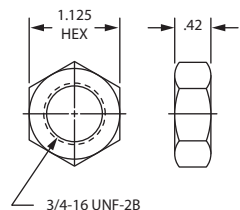
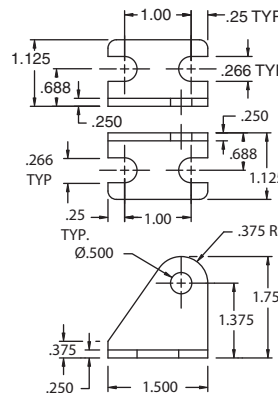

Mounting Nut
 F-M190006
 Price: \$0.51

F Series

1-3/4" Bore Cylinders



MOUNTING NUT INCLUDED

Single Acting Spring Return

Front Nose Mount

Standard Stroke Lengths:

1/2", 1", 1-1/2", 2", 2-1/2", 3", 4"

Maximum Stroke: 6"

Optional Accessories:

- F-M117008 Mounting Bracket
- F-M127006 Rod Clevis

Base Weight: .85 lbs.

Plus .36 lbs. per inch of stroke

F-1750S01-00A

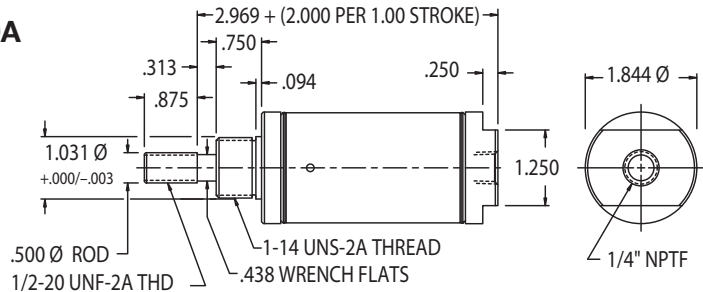

\$41.97 Base Price
Add \$5.49 per inch of stroke

BUMPER AVAILABLE CAP END ONLY - NO CHANGE IN OAL..... \$4.01
 MAGNETIC PISTON OPTION - ADD .656 TO OAL..... \$26.25
 BOTH BUMPER & MAGNETIC PISTON OPTIONS - ADD .735 TO OAL

Single Acting Spring Return

Double Nose or Rear Pivot Mount

Standard Stroke Lengths:

1/2", 1", 1-1/2", 2", 2-1/2", 3", 4"

Maximum Stroke: 6"

Optional Accessories:

- F-M117008 Mounting Bracket
- F-M129005 Pivot Bracket
- F-M127006 Rod Clevis

Base Weight: .86 lbs.

Plus .36 lbs. per inch of stroke

F-1750S02-00A

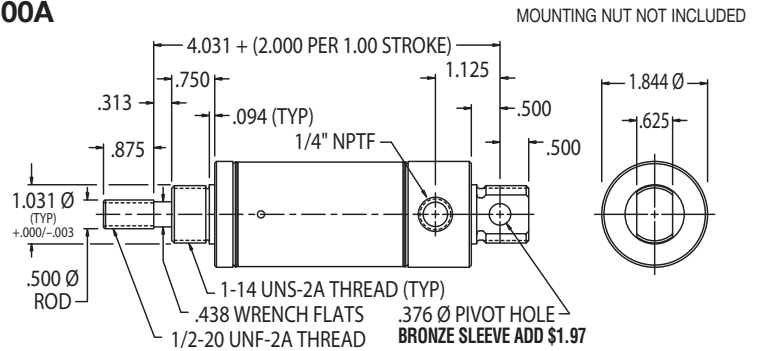

\$43.92 Base Price
Add \$5.49 per inch of stroke

BUMPER AVAILABLE CAP END ONLY - NO CHANGE IN OAL..... \$4.01
 MAGNETIC PISTON OPTION - ADD .656 TO OAL..... \$26.43
 BOTH BUMPER & MAGNETIC PISTON OPTIONS - ADD .735 TO OAL

Single Acting Spring Extend

Front Nose Mount

Standard Stroke Lengths:

1/2", 1", 1-1/2", 2", 2-1/2", 3", 4"

Maximum Stroke: 6"

Optional Accessories:

- F-M117008 Mounting Bracket
- F-M127006 Rod Clevis

Base Weight: 1.17 lbs.

Plus .31 lbs. per inch of stroke

F-1750R01-00A

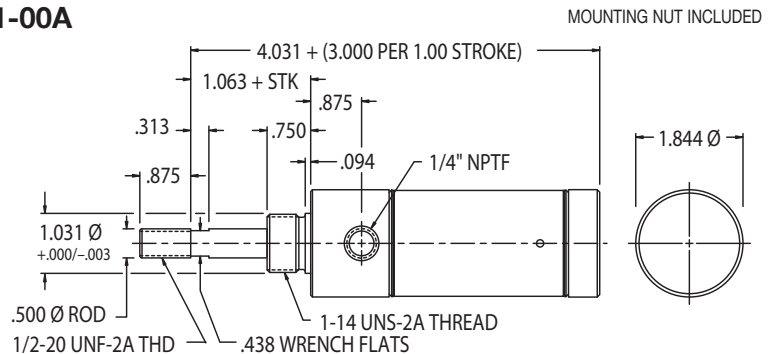

\$50.71 Base Price
Add \$5.49 per inch of stroke

BUMPER AVAILABLE ROD END ONLY - NO CHANGE IN OAL..... \$4.07
 MAGNETIC PISTON OPTION - ADD .656 TO OAL..... \$27.17
 BOTH BUMPER & MAGNETIC PISTON OPTIONS - ADD .735 TO OAL

Double Acting

Front Nose Mount

Standard Stroke Lengths:

1/2", 1", 1-1/2", 2", 2-1/2", 3", 4",

5", 6", 7", 8", 9", 10", 11", 12"

Maximum Stroke: 12"

Optional Accessories:

- F-M117008 Mounting Bracket
- F-M127006 Rod Clevis

Base Weight: 1.29 lbs.

Plus .11 lbs. per inch of stroke

F-1750D01-00A

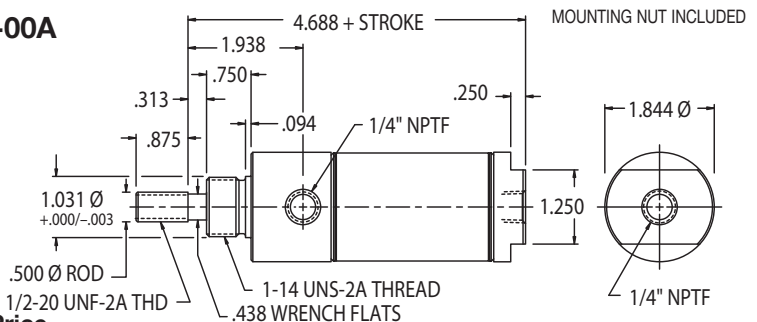

\$51.02 Base Price
Add \$2.46 per inch of stroke

BUMPER OPTION - NO CHANGE IN OAL..... \$6.36
 MAGNETIC PISTON OPTION - NO CHANGE IN OAL..... \$11.70
 BOTH BUMPER & MAGNETIC PISTON OPTIONS - NO CHANGE IN OAL

Specifications and prices subject to change without notice or incurring obligation

See pricing notes on Page 5

2-23-10

MOUNTING NUT NOT INCLUDED

F Series 1-3/4" Bore Cylinders

F-1750D02-00A

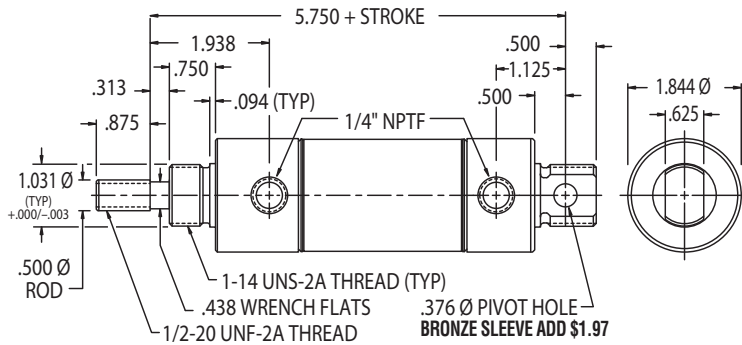

Double Acting

Double Nose or Rear Pivot Mount

Standard Stroke Lengths:

1/2", 1", 1-1/2", 2", 2-1/2", 3", 4",
 5", 6", 7", 8", 9", 10", 11", 12"

Maximum Stroke: 32"

Optional Accessories:

- F-M117008 Mounting Bracket
- F-M129005 Pivot Bracket
- F-M127006 Rod Clevis

Base Weight: 1.64 lbs.

Plus .11 lbs. per inch of stroke

\$57.24 Base Price
 Add \$2.46 per inch of stroke

- BUMPER OPTION - NO CHANGE IN OAL \$6.36
- MAGNETIC PISTON OPTION - NO CHANGE IN OAL \$11.79
- BOTH BUMPER & MAGNETIC PISTON OPTIONS - NO CHANGE IN OAL

1-3/4" Bore Cylinder Specifications – Options & Accessories

- -10° to +165°F
- Piston Rod: Ground and Polished, 303 Stainless Steel.
- Bronze rod guide bushing is standard.
- Approximate force exerted = (2.4) x (air line pressure).
- Spring force: 11 lbs. relaxed, 24 lbs. compressed.
- Mounting nuts are standard on all nose mount cylinders.
- Bumpers are optional on all 1-3/4" bore cylinders (except in combination with Viton® option).
- Magnetic piston optional on all 1-3/4" bore cylinders (except in combination with Viton® option).

OPTION	PRICE ADDER
• Viton® Seals – Not available with bumpers or magnetic piston	
Spring Return (-15° F to 300° F)	\$7.64
Double Acting (-15° F to 350° F)	\$18.86
Spring Extend (-15° F to 300° F)	\$14.05
• Ports Rotated – 90° on S02 or D02 models (both)	No charge
• Rod Wiper – Not available in spring return models	\$7.10
• Side Port - Cap end ports on S01 or D01 models	
Add .56 to OAL	No charge
• Low Temperature Seals – Applications to -40° F	\$4.83
• Rod Extension	\$1.17/inch
• Rod Thread Extension	\$2.23/inch

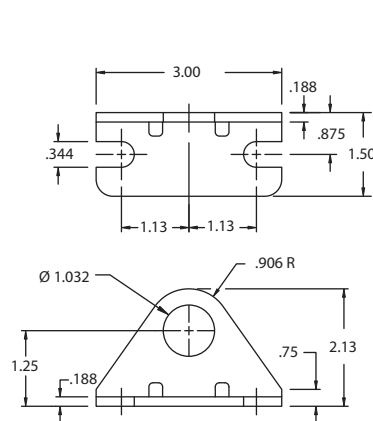

Mounting Bracket
 F-M117008
 Price: \$5.80

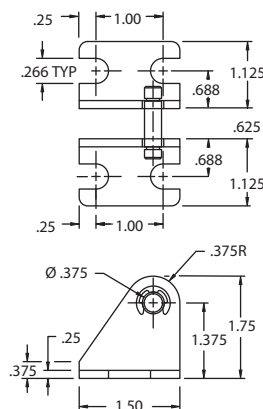

Pivot Bracket
 F-M129005
 Price: \$10.70

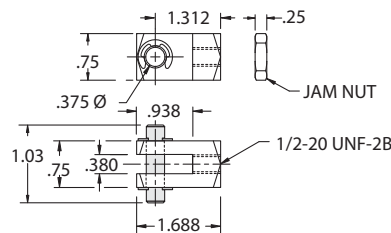

Rod Clevis
 F-M127006
 Price: \$5.80

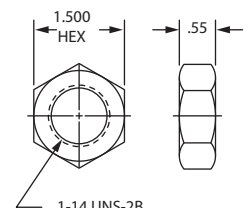

Mounting Nut
 F-M190008
 Price: \$2.36

F Series

2" Bore Cylinders



Single Acting Spring Return Front Nose Mount

Standard Stroke Lengths:
1/2", 1", 1-1/2", 2", 2-1/2", 3", 4"
Maximum Stroke: 4"

- Optional Accessories:
- F-M117009 Mounting Bracket
 - F-M127006 Rod Clevis
- Base Weight: 1.04 lbs.
Plus .43 lbs. per inch of stroke

F-2000S01-00A

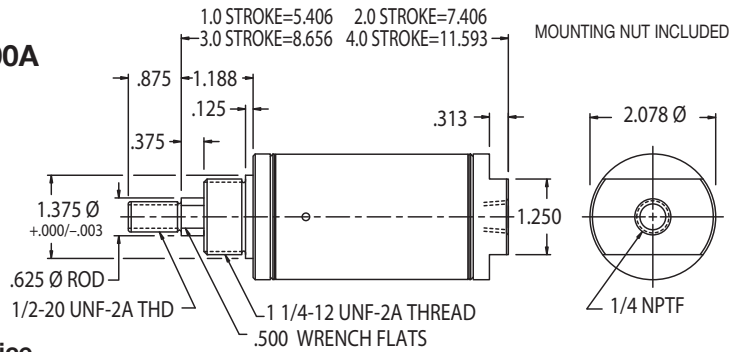

\$55.44 Base Price
Add \$5.86 per inch of stroke

BUMPER AT CAP END ONLY - NO CHANGE IN OAL \$4.20
MAGNETIC PISTON OPTION - ADD .461 TO OAL \$27.60
BOTH BUMPER & MAGNETIC PISTON OPTIONS - ADD .789 TO OAL

Single Acting Spring Return Double Nose or Rear Pivot Mount

Standard Stroke Lengths:
1/2", 1", 1-1/2", 2", 2-1/2", 3", 4"
Maximum Stroke: 4"

- Optional Accessories:
- F-M117009 Mounting Bracket
 - F-M229005 Pivot Bracket
 - F-M127006 Rod Clevis
- Base Weight: 1.26 lbs.
Plus .43 lbs. per inch of stroke

F-2000S02-00A

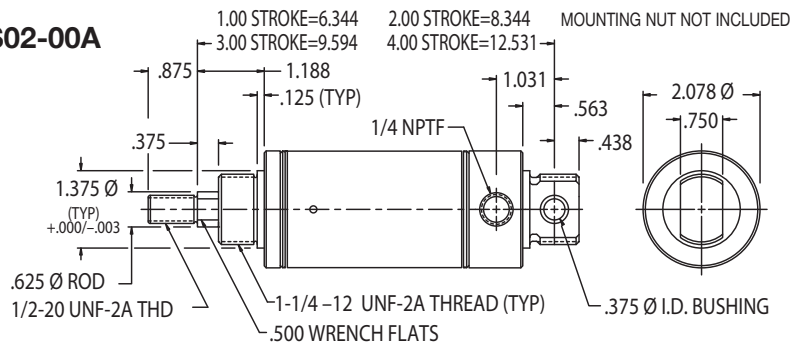

\$67.76 Base Price
Add \$6.09 per inch of stroke

BUMPER AT CAP END ONLY - NO CHANGE IN OAL \$4.20
MAGNETIC PISTON OPTION - ADD .461 TO OAL \$28.83
BOTH BUMPER & MAGNETIC PISTON OPTIONS - ADD .789 TO OAL

Single Acting Spring Extend Front Nose Mount

Standard Stroke Lengths:
1/2", 1", 1-1/2", 2", 2-1/2", 3", 4"
Maximum Stroke: 4"

- Optional Accessories:
- F-M117009 Mounting Bracket
 - F-M127006 Rod Clevis
- Base Weight: 1.24 lbs.
Plus .43 lbs. per inch of stroke

F-2000R01-00A

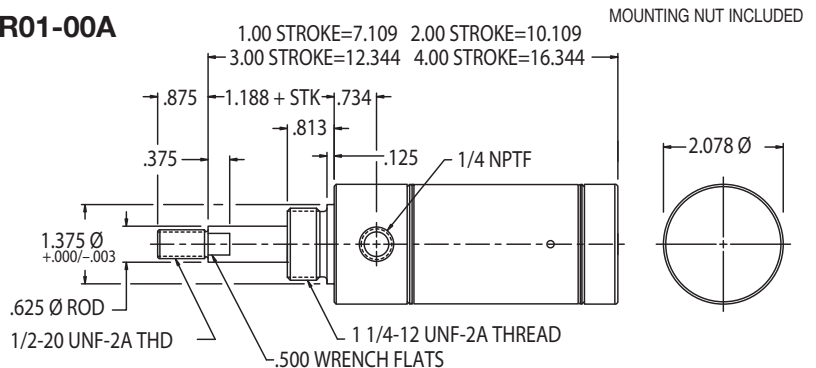

\$64.38 Base Price
Add \$5.86 per inch of stroke

BUMPER AT ROD END ONLY - NO CHANGE IN OAL \$4.20
MAGNETIC PISTON OPTION - ADD .714 TO OAL \$28.40
BOTH BUMPER & MAGNETIC PISTON OPTIONS - ADD .789 TO OAL

Single Acting Spring Extend Double Nose or Rear Pivot Mount

Standard Stroke Lengths:
1/2", 1", 1-1/2", 2", 2-1/2", 3", 4"
Maximum Stroke: 4"

- Optional Accessories:
- F-M117009 Mounting Bracket
 - F-M229005 Pivot Bracket
 - F-M127006 Rod Clevis
- Base Weight: 1.46 lbs.
Plus .43 lbs. per inch of stroke

F-2000R02-00A

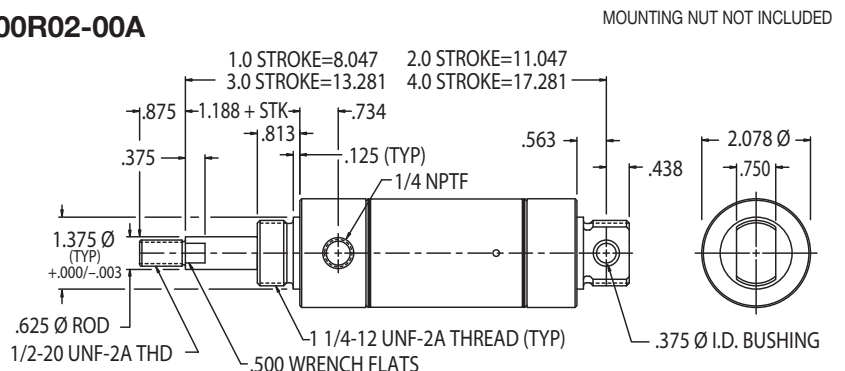

\$70.36 Base Price
Add \$5.86 per inch of stroke

BUMPER AT ROD END ONLY - NO CHANGE IN OAL \$4.20
MAGNETIC PISTON OPTION - ADD .714 TO OAL \$29.14
BOTH BUMPER & MAGNETIC PISTON OPTIONS - ADD .789 TO OAL

MOUNTING NUT INCLUDED

F-2000D01-00A

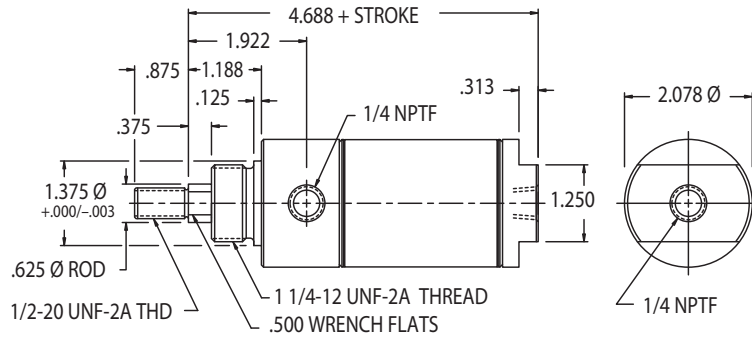

Double Acting

Front Nose Mount

Standard Stroke Lengths:

1/2", 1", 1-1/2", 2", 2-1/2", 3", 4", 5", 6", 7", 8"

Maximum Stroke: 12"

Optional Accessories:

- F-M117009 Mounting Bracket
- F-M127006 Rod Clevis

Base Weight: 1.40 lbs.

Plus .15 lbs. per inch of stroke

BUMPER OPTION - ADD .250 TO OAL.....\$6.61
 MAGNETIC PISTON OPTION - NO CHANGE IN OAL\$11.79
 BOTH BUMPER & MAGNETIC PISTON OPTIONS - ADD .250 TO OAL

\$53.43 Base Price

Add \$2.78 per inch of stroke

MOUNTING NUT NOT INCLUDED

F-2000D02-00A

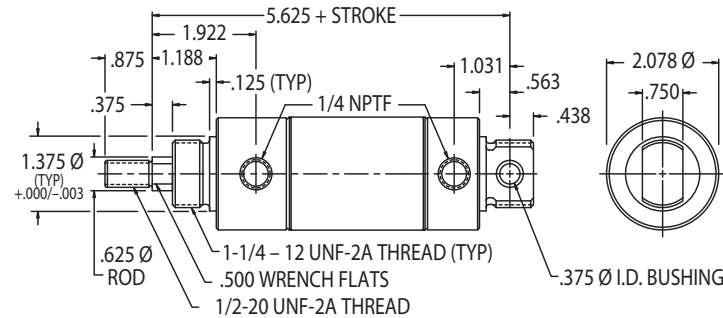

Double Acting

Double Nose or Rear Pivot Mount

Standard Stroke Lengths:

1/2", 1", 1-1/2", 2", 2-1/2", 3", 4", 5", 6", 7", 8", 9", 10", 11", 12"

Maximum Stroke: 32"

Optional Accessories:

- F-M117009 Mounting Bracket
- F-M229005 Pivot Bracket
- F-M127006 Rod Clevis

Base Weight: 1.62 lbs.

Plus .15 lbs. per inch of stroke

BUMPER OPTION - ADD .250 TO OAL.....\$6.53
 MAGNETIC PISTON OPTION - NO CHANGE IN OAL\$11.70
 BOTH BUMPER & MAGNETIC PISTON OPTIONS - ADD .250 TO OAL

\$64.26 Base Price

Add \$2.91 per inch of stroke

MOUNTING NUT INCLUDED

F-2000D03-00A

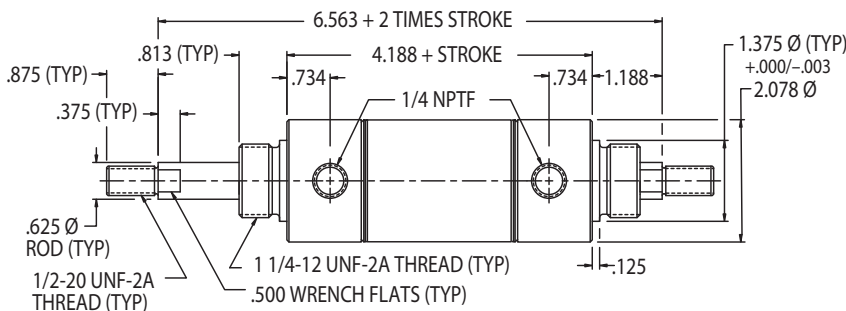

Double Acting

Double Rod

Standard Stroke Lengths:

1/2", 1", 1-1/2", 2", 2-1/2", 3", 4", 5", 6"

Maximum Stroke: 12"

*Optional Accessories:

- F-M117009 Mounting Bracket
- F-M127006 Rod Clevis

Base Weight: 1.97 lbs.

Plus .24 lbs. per inch of stroke

BUMPER OPTION - ADD .250 TO OAL.....\$6.96
 MAGNETIC PISTON OPTION - NO CHANGE IN OAL\$12.69
 BOTH BUMPER & MAGNETIC PISTON OPTIONS - ADD .250 TO OAL

\$79.53 Base Price

Add \$4.20 per inch of stroke

F Series

2" Bore Cylinders



Double Acting
 Front Nose Mount
 with **Adjustable Cushions**
 Standard Stroke Lengths:
1/2", 1", 1-1/2", 2", 2-1/2", 3", 4", 5", 6"
 Maximum Stroke: 12"
 Optional Accessories:
 • F-M117009 Mounting Bracket
 • F-M127006 Rod Clevis
 Base Weight: 1.64 lbs.
 Plus .15 lbs. per inch of stroke

F-2000DG1-00A

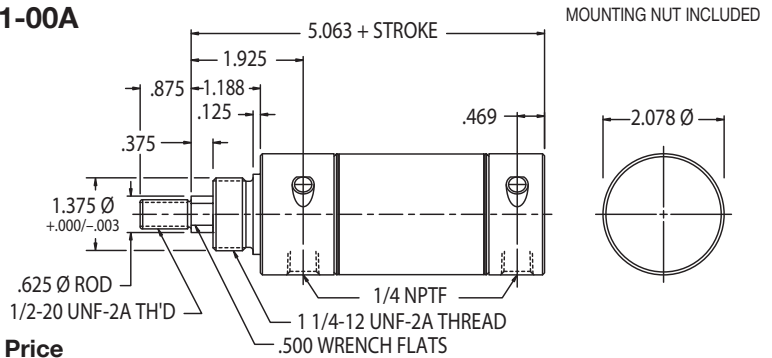

\$82.79 Base Price
Add \$2.78 per inch of stroke
Viton® Seals – Consult Factory

MAGNETIC PISTON OPTION - NO CHANGE IN OAL..... \$11.79

Double Acting
 Rear Pivot Mount
 with **Adjustable Cushions**
 Standard Stroke Lengths:
1/2", 1", 1-1/2", 2", 2-1/2", 3", 4", 5", 6"
 Maximum Stroke: 32"
 Optional Accessories:
 • F-M117009 Mounting Bracket
 • F-M229005 Pivot Bracket
 • F-M127006 Rod Clevis
 Base Weight: 1.68 lbs.
 Plus .15 lbs. per inch of stroke

F-2000DG2-00A

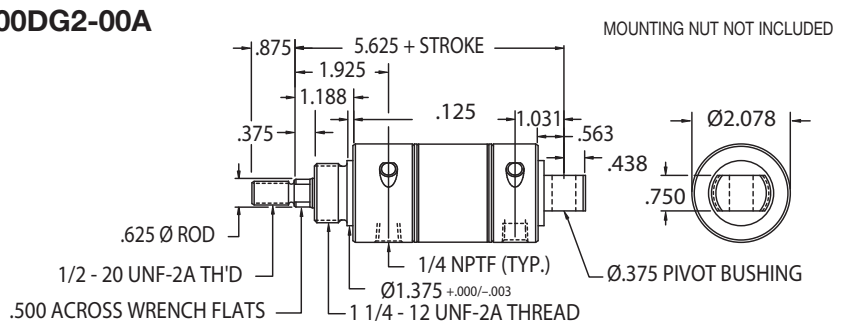

\$99.55 Base Price
Add \$2.91 per inch of stroke
Viton® Seals – Consult Factory

MAGNETIC PISTON OPTION - NO CHANGE IN OAL..... \$11.79

Double Acting
 Front Nose Mount
1" Diameter Rod
 with Wear Band Piston
Standard Stroke Lengths:
1/2", 1", 1-1/2", 2", 2-1/2", 3", 4", 5", 6"
 Maximum Stroke: 12"
 Base Weight: approximately 1.79 lbs.
 Plus .28 lbs. per inch of stroke

F-2000DL1-00A

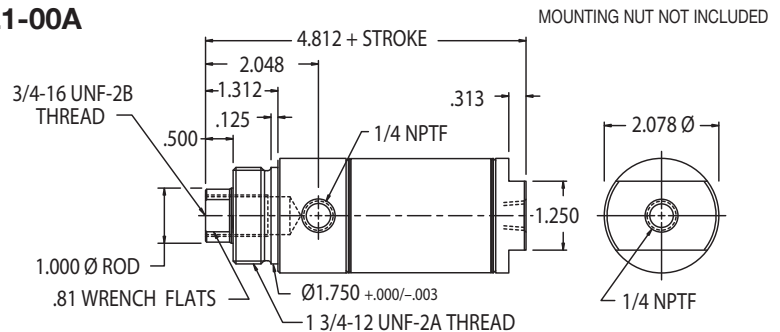

\$174.90 Base Price
Add \$5.18 per inch of stroke

BUMPERS NOT AVAILABLE
 MAGNETIC PISTON OPTION - ADD .299 TO OAL..... \$11.70

Double Acting
 Rear Pivot Mount
1" Diameter Rod
 with Wear Band Piston
Standard Stroke Lengths:
1/2", 1", 1-1/2", 2", 2-1/2", 3", 4", 5", 6"
 Maximum Stroke: 32"
 Base Weight: approximately 2.01 lbs.
 Plus .28 lbs. per inch of stroke

F-2000DL2-00A

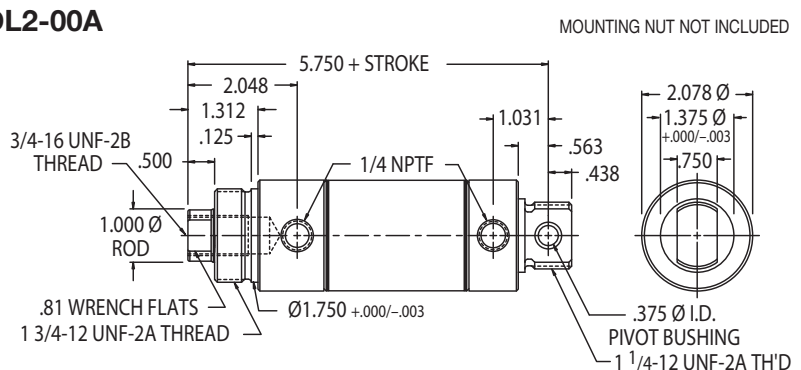

\$185.37 Base Price
Add \$5.18 per inch of stroke

BUMPERS NOT AVAILABLE
 MAGNETIC PISTON OPTION - ADD .299 TO OAL..... \$11.79

Standard Cylinder Specifications – Options & Accessories

- -10° to +165°F
- Piston Rod: Ground and Polished, 303 Stainless Steel (Except for 1" Rod Models. See below).
- Bronze rod guide bushing is standard.
- Approximate force exerted = (3.1) x (air line pressure).
- Spring force: 15 lbs. relaxed, 30 lbs. compressed.
- Mounting nuts are standard on all nose mount cylinders except 1" rod models.
- Bumpers are optional on all 2" bore cylinders (except in combination with Viton® option).
- Magnetic piston optional on all 2" bore cylinders (except in combination with Viton® option).

1" Rod Cylinder Specifications

- 1" chrome rod is standard.
- Magnetic piston optional.
- Viton® seals optional.

OPTION	PRICE ADDER
• Viton® Seals – Not available with bumpers or magnetic piston	
Spring Return (-15° F to 300° F)	\$7.64
Double Acting (-15° F to 350° F)	\$18.62
D02 – Double Acting (-15° F to 350° F)	\$18.56
R01 – Spring Extend (-15° F to 300° F)	\$14.00
R02 – Spring Extend (-15° F to 300° F)	\$14.05
Double Rod (-15° F to 350° F)	\$26.18
• Ports Rotated – 90°	
on S02, R02, or D02 models (both)	No charge
• Rod Wiper – Not available in spring return models	\$7.10
• Side Port - Cap end port on S01 or D01 models	
Add .38 to OAL	No charge
• Low Temperature Seals – Applications to -40° F	10.88
• Rod Extension - Single, reverse and double acting	\$1.54/inch
• Rod Thread Extension	\$2.60/inch

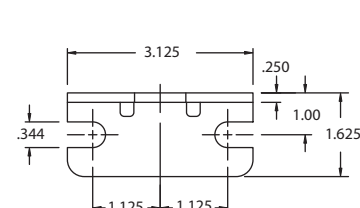

Mounting Bracket

F-M117009

Price: \$7.65

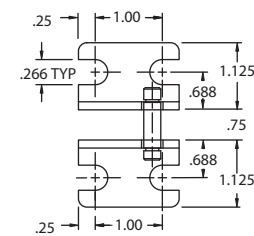

Pivot Bracket

F-M229005

Price: \$10.70

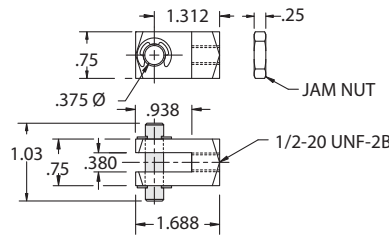

Rod Clevis

F-M127006

Price: \$5.80

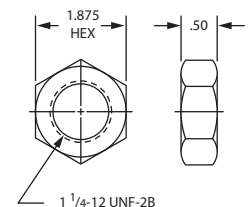

Mounting Nut

F-M190009

Price: \$3.64

F Series

2-1/2" Bore Cylinders



Double Acting

Front Nose Mount

Standard Stroke Lengths:

1/2", 1", 1-1/2", 2", 2-1/2", 3", 4",
5", 6", 7", 8", 9", 10", 11", 12"

Maximum Stroke: 12"

Optional Accessories:

- F-M117010 Mounting Bracket
- F-M127006 Rod Clevis
- F-M190012 Mounting Nut

Base Weight 1.98 lbs.

Plus .17 lbs. per inch of stroke

F-2500D01-00A

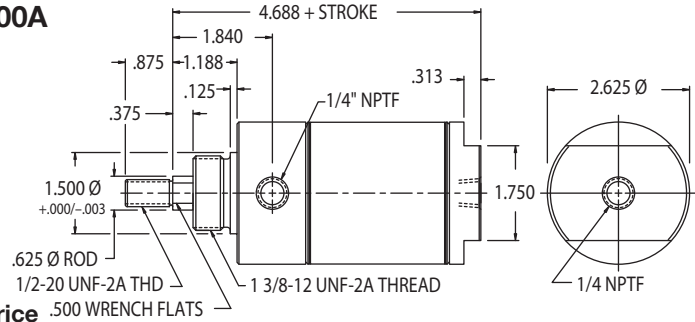

\$81.51 Base Price
Add \$3.14 per inch of stroke

- BUMPER OPTION - ADD .062 TO OAL \$24.29
- MAGNETIC PISTON OPTION - NO CHANGE IN OAL \$17.19
- BOTH BUMPER & MAGNETIC PISTON OPTIONS - ADD .062 TO OAL

MOUNTING NUT NOT INCLUDED

Double Acting

Rear Pivot Mount

Standard Stroke Lengths:

1/2", 1", 1-1/2", 2", 2-1/2", 3", 4",
5", 6", 7", 8", 9", 10", 11", 12"

Maximum Stroke: 32"

Optional Accessories:

- F-M117010 Mounting Bracket
- F-M229005 Pivot Bracket
- F-M127006 Rod Clevis
- F-M190012 Mounting Nut

Base Weight: 2.27 lbs.

Plus .17 lbs. per inch of stroke

F-2500D02-00A

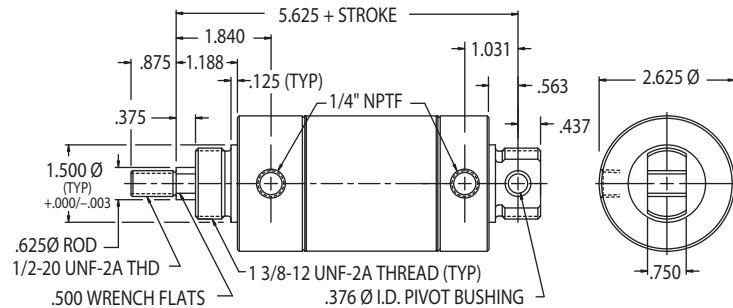

\$97.22 Base Price
Add \$3.26 per inch of stroke

- BUMPER OPTION - ADD .062 TO OAL \$24.29
- MAGNETIC PISTON OPTION - NO CHANGE IN OAL \$17.13
- BOTH BUMPER & MAGNETIC PISTON OPTIONS - ADD .062 TO OAL

MOUNTING NUT NOT INCLUDED

2-1/2" Bore Cylinder Specifications – Options & Accessories

- -10° to +165°F
- Piston Rod: Ground and Polished, 303 Stainless Steel.
- Bronze rod guide bushing is standard.
- Approximate force exerted = (5.0) x (air line pressure).
- Magnetic piston optional on all 2-1/2" bore cylinders (except in combination with Viton option).

OPTION	PRICE ADDER
• Viton® Seals – Not available with bumpers or magnetic piston	
D01 – Double Acting (-15° F to 350° F)	\$22.68
D02 – Double Acting (-15° F to 350° F)	\$22.63
• Ports Rotated – 90° on D02 (both).....	No charge
• Rod Wiper –	\$7.10
• Side Port – Cap end on D01. Add .38 to overall length ...	No charge
• Low Temperature Seals – Applications to -40° F	\$8.07
• Rod Extension	\$1.54/inch
• Rod Thread Extension.....	\$2.60/inch

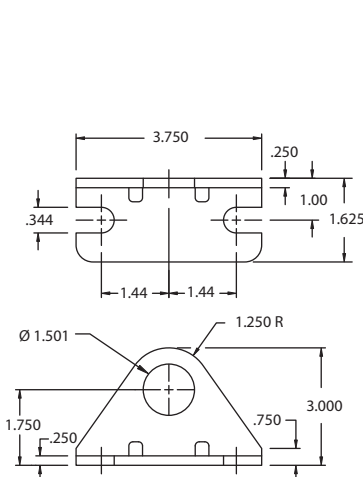

Mounting Bracket
F-M117010
Price: \$20.46

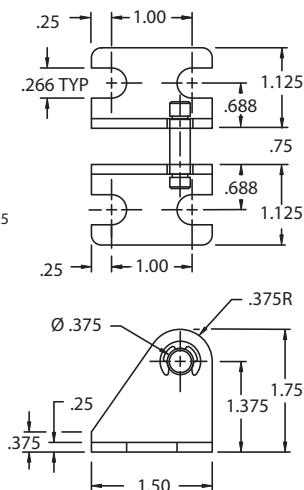

Pivot Bracket
F-M229005
Price: \$10.70

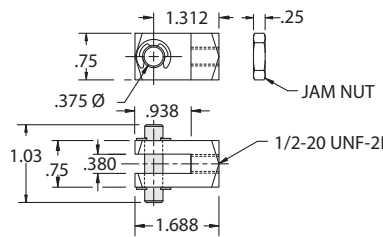

Rod Clevis
F-M127006
Price: \$5.80

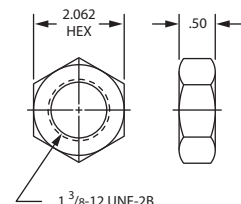

Mounting Nut
F-M190012
Price: \$5.74

MOUNTING NUT NOT INCLUDED

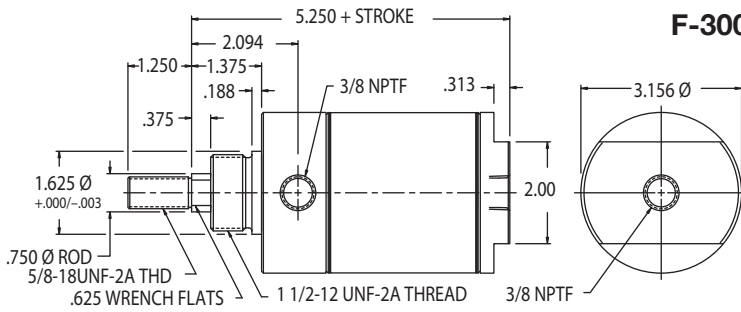

F-3000D01-00A

Double Acting

Front Nose Mount

Standard Stroke Lengths:

1/2", 1", 1-1/2", 2", 2-1/2", 3", 4", 5", 6"

Maximum Stroke: 12"

*Optional Accessories:

• F-M117011 Mounting Bracket

• F-M127007 Rod Clevis

• F-M190013 Mounting Nut

Base Weight: 3.34 lbs.

Plus .26 lbs. per inch of stroke

BUMPER OPTION - ADD .062 TO OAL.....\$24.29

MAGNETIC PISTON OPTION - NO CHANGE IN OAL.....\$28.59

BOTH BUMPER & MAGNETIC PISTON OPTIONS - ADD .062 TO OAL

\$116.80 Base Price

Add \$3.75 per inch of stroke

MOUNTING NUT NOT INCLUDED

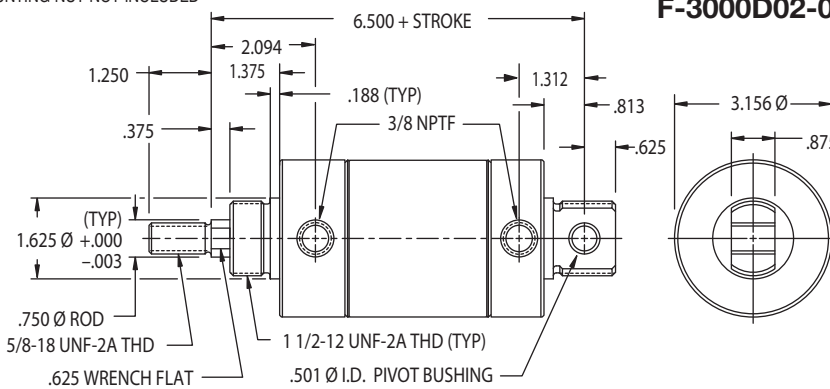

F-3000D02-00A

Double Acting

Double Nose or Rear Pivot Mount

Standard Stroke Lengths:

1/2", 1", 1-1/2", 2", 2-1/2", 3", 4", 5", 6"

Maximum Stroke: 32"

*Optional Accessories:

• F-M117011 Mounting Bracket

• F-M229006 Pivot Bracket

• F-M127007 Rod Clevis

• F-M190013 Mounting Nut

Base Weight: 3.87 lbs.

Plus .26 lbs. per inch of stroke

BUMPER OPTION - ADD .062 TO OAL.....\$24.29

MAGNETIC PISTON OPTION - NO CHANGE IN OAL.....\$28.59

BOTH BUMPER & MAGNETIC PISTON OPTIONS - ADD .062 TO OAL

\$131.05 Base Price

Add \$4.01 per inch of stroke

3" Bore Cylinder Specifications – Options & Accessories

- -10° to +165°F
- Piston Rod
Ground and Polished, 303 Stainless Steel is standard.
- Bronze rod guide bushing is standard.
- Approximate force exerted = (7.0) x (air line pressure).
- Magnetic piston optional on all 3" bore cylinders (except in combination with Viton option).

OPTION	PRICE ADDER
• Viton® Seals – Not available with bumpers or magnetic piston Double Acting (-15° F to 350° F).....	\$24.59
• Ports Rotated – 90° on D02 model (both).....	No charge
• Rod Wiper –	\$7.10
• Side Port – Cap end on D01. Add .44 to OAL.....	No charge
• Low Temperature Seals – Applications to -40° F	\$10.88
• Rod Extension	\$1.74/inch
• Rod Thread Extension.....	\$2.78/inch

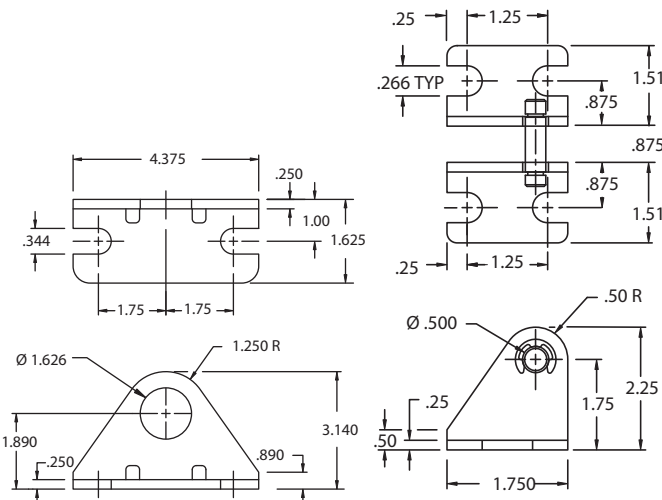

Mounting Bracket

F-M117011

Price: \$13.31

Pivot Bracket

F-M229006

Price: \$14.67

Rod Clevis

F-M127007

Price: \$15.50

Mounting Nut

F-M190013

Price: \$5.74

F Series

Volume Chambers



How to Order

F-1500 V 01 - 01 A

Series

Bore Size (4 digits)

- 0750 = 3/4"
- 1062 = 1-1/16"
- 1500 = 1-1/2"
- 2000 = 2"
- 2500 = 2-1/2"
- 3000 = 3"

Style

V = Volume chamber

Version

01 = In-line mount

Fractional Inch Length

(1 digit)

A = 0"

Full Inch Length (2 digits)

00 = 0"

01 = 1"

02 = 2"

03 = 3"

.

.

32 = 32"

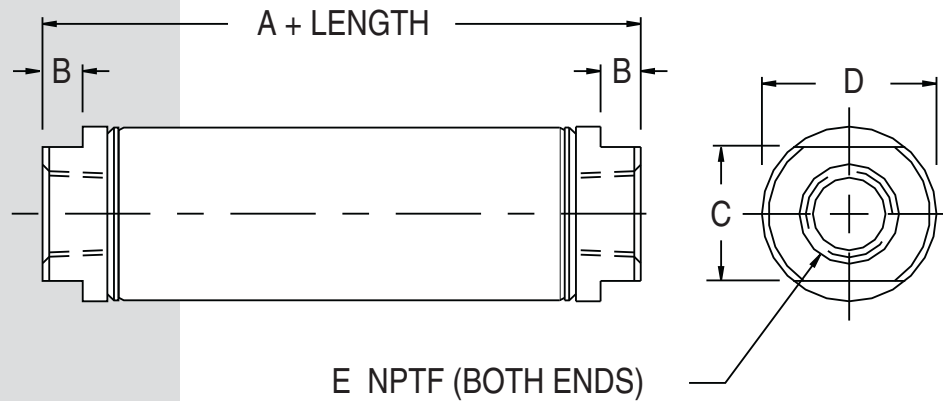

Bore	A	B	C	D	E	INCHES ³ PER INCH	STANDARD LENGTH	MAX. LENGTH	BASE PRICE	PRICE/INCH
3/4"	1.062	0.19	0.625	0.813	1/8	0.44	1" Increments to 4"	32"	\$7.71	\$0.80
1-1/16"	1.188	0.19	0.875	1.125	1/8	0.88	1" Increments to 8"	32"	8.55	1.07
1-1/2"	1.375	0.25	0.875	1.563	1/8	1.76	1" Increments to 16"	32"	20.95	1.74
2"	1.767	0.31	1.250	2.087	1/4	3.14	1" Increments to 16"	32"	26.18	1.97
2-1/2"	1.767	0.31	1.750	2.625	1/4	4.9	1" Increments to 24"	32"	44.68	2.78
3"	2.000	0.31	2.000	3.156	3/8	7.0	1" Increments to 24"	32"	51.12	3.75

Volume Chamber Specifications

- -40° to +350°F
- 303 stainless steel body.
- Aluminum alloy end caps.
- Pressure rating: 250 psi.

Features

- Delrin® head, Delrin® cap and aluminum piston provide excellent corrosion resistance in wash down environments where cylinders are exposed to moisture and certain solvents.*
- Stainless steel rod and tube complete the corrosion resistance package and provide long life.
- Corrosion resistant cylinders are offered in three standard bore sizes: 3/4", 1-1/16" and 1-1/2" with both nose and rear pivot mounts.
- Stroke tolerance +/- .032

Delrin® is a registered trademark of DuPont.

★ Call DuPont (800) 441-0575 for information regarding properties of this material.



- Max Operating Pressure: 100 psi Air
- Temperature Range: 32°F to 160°F (0°C to 72°C)

MOUNTING NUT NOT INCLUDED

F-0750DC1-00A

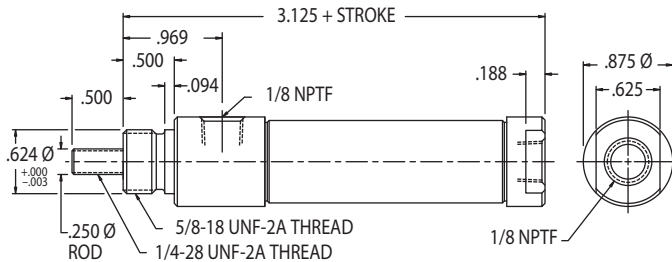

- BUMPERS OPTION - ADD .281 TO OAL.....\$4.20
- MAGNETIC PISTON OPTION - ADD .281 TO OAL.....\$10.74
- BUMPERS WITH MAGNETIC PISTON OPTION - ADD .406 TO OAL

\$34.94 Base Price
 Add \$1.60 per inch of stroke

3/4" Bore Delrin® Series

Double Acting Front Nose Mount

Standard Stroke Lengths:

1/2", 1", 1-1/2", 2", 2-1/2", 3", 4", 5", 6"

Maximum Stroke: 12"

*Optional Accessories:

- F-M19S005 Stainless Steel Mounting Nut
- Base Weight: .13 lbs.
- Plus .03 lbs. per inch of stroke

MOUNTING NUT NOT INCLUDED

F-0750DC2-00A

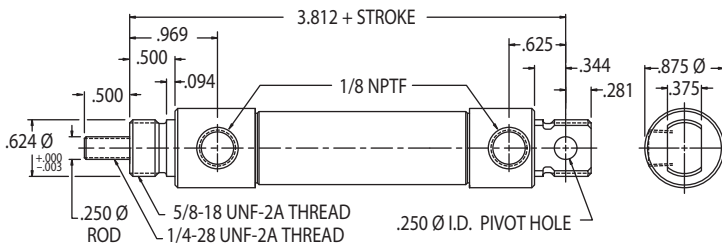

- BUMPERS OPTION - ADD .281 TO OAL.....\$4.20
- MAGNETIC PISTON OPTION - ADD .281 TO OAL.....\$10.74
- BUMPERS WITH MAGNETIC PISTON OPTION - ADD .406 TO OAL

\$38.21 Base Price
 Add \$1.60 per inch of stroke

3/4" Bore Delrin® Series

Double Acting Rear Pivot Mount

Standard Stroke Lengths:

1/2", 1", 1-1/2", 2", 2-1/2", 3", 4", 5", 6"

Maximum Stroke: 32"

*Optional Accessories:

- F-M19S005 Stainless Steel Mounting Nut
- Base Weight: .15 lbs.
- Plus .03 lbs. per inch of stroke

MOUNTING NUT NOT INCLUDED

F-0750DC3-00A

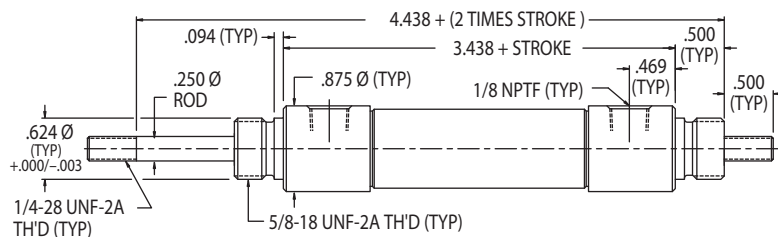

- BUMPERS OPTION - ADD .250 TO OAL AND BODY LENGTH.....CF
- MAGNETIC PISTON OPTION - NO CHANGE IN OAL.....CF
- BUMPERS WITH MAGNETIC PISTON OPTION - ADD .250 TO OAL AND BODY LENGTH

\$42.47 Base Price
 Add \$2.11 per inch of stroke

3/4" Bore Delrin® Series

Double Acting Double Rod

Standard Stroke Lengths:

1/2", 1", 1-1/2", 2", 2-1/2", 3", 4", 5", 6"

Maximum Stroke: 12"

*Optional Accessories:

- F-M19S005 Stainless Steel Mounting Nut
- Base Weight: .18 lbs.
- Plus .05 lbs. per inch of stroke

F Series

Delrin® Corrosion Resistant Cylinders



1-1/16" Bore Delrin® Series
 Double Acting Front Nose Mount
 Standard Stroke Lengths:
 1/2", 1", 1-1/2", 2", 2-1/2", 3", 4", 5", 6"
 Maximum Stroke: 12"
 Optional Accessories:
 • F-M19S005 Stainless Steel Mounting Nut
 Base Weight: .21 lbs.
 Plus .05 lbs. per inch of stroke

F-1062DC1-00A

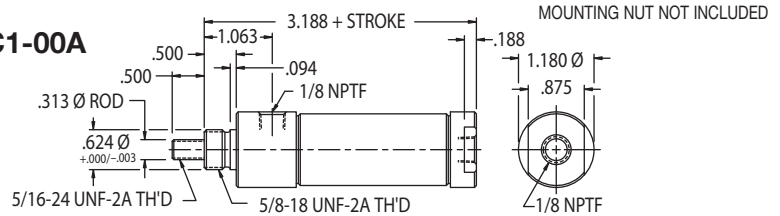

\$36.23 Base Price
Add \$1.60 per inch of stroke

BUMPERS OPTION - ADD .375 TO OAL \$4.20
 MAGNETIC PISTON OPTION - ADD .250 TO OAL \$10.74
 BUMPERS WITH MAGNETIC PISTON OPTIONS - ADD .375 TO OAL

1-1/16" Bore Delrin® Series
 Double Acting Rear Pivot Mount
 Standard Stroke Lengths:
 1/2", 1", 1-1/2", 2", 2-1/2", 3", 4", 5", 6", 7", 8", 9", 10", 11", 12"
 Maximum Stroke: 32"
 Optional Accessories:
 • F-M19S005 Stainless Steel Mounting Nut
 Base Weight: .25 lbs.
 Plus .05 lbs. per inch of stroke

F-1062DC2-00A

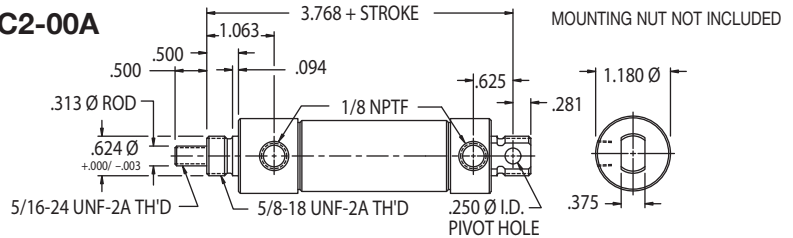

\$39.49 Base Price
Add \$1.60 per inch of stroke

BUMPERS OPTION - ADD .375 TO OAL \$4.20
 MAGNETIC PISTON OPTION - ADD .250 TO OAL \$10.74
 BUMPERS WITH MAGNETIC PISTON OPTIONS - ADD .375 TO OAL

1-1/16" Bore Delrin® Series
 Double Acting Double Rod
 Standard Stroke Lengths:
 1/2", 1", 1-1/2", 2", 2-1/2", 3", 4", 5", 6"
 Maximum Stroke: 12"
 Optional Accessories:
 • F-M19S005 Stainless Steel Mounting Nut
 Base Weight: .30 lbs.
 Plus .07 lbs. per inch of stroke

F-1062DC3-00A

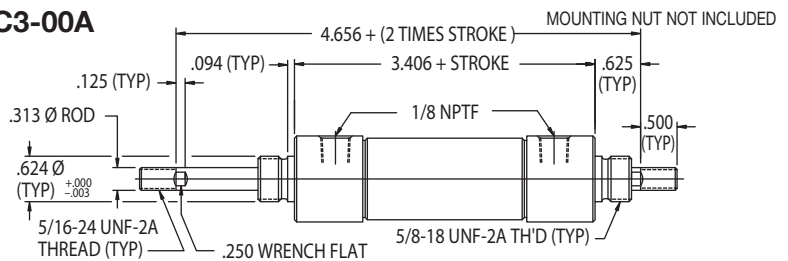

\$47.06 Base Price
Add \$2.11 per inch of stroke

BUMPERS OPTION - ADD .250 TO OAL & BODY LENGTH CF
 MAGNETIC PISTON OPTION - NO CHANGE IN OAL CF
 BUMPERS WITH MAG. PISTON - ADD .250 TO OAL & BODY LENGTH

1-1/2" Bore Delrin® Series
 Double Acting
Front Nose Mount
 Standard Stroke Lengths:
 1/2", 1", 1-1/2", 2", 2-1/2", 3", 4", 5", 6"
 Maximum Stroke: 12"
 Optional Accessories:
 • F-M19S006 Stainless Steel Mounting Nut
 Base Weight: .46 lbs.
 Plus .08 lbs. per inch of stroke

F-1500DC1-00A

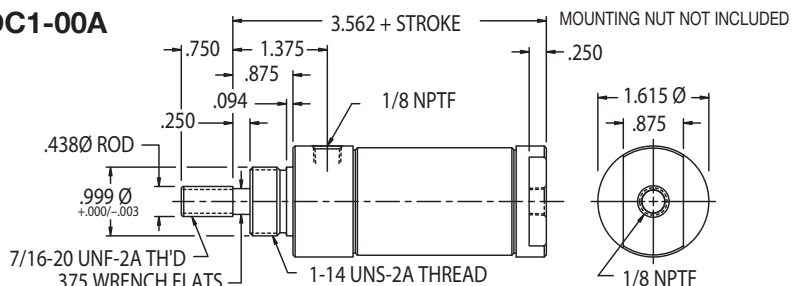

\$46.58 Base Price
Add \$2.46 per inch of stroke

BUMPERS OPTION - ADD .375 TO OAL \$5.13
 MAGNETIC PISTON OPTION - ADD .250 TO OAL \$10.74
 BUMPERS WITH MAGNETIC PISTON OPTIONS - ADD .500 TO OAL

1-1/2" Bore Delrin® Series
 Double Acting Rear Pivot Mount
 Standard Stroke Lengths:
 1/2", 1", 1-1/2", 2", 2-1/2", 3", 4", 5", 6", 7", 8", 9", 10", 11", 12"
 Maximum Stroke: 32"
 Optional Accessories:
 • F-M19S006 Stainless Steel Mounting Nut
 Base Weight: .48 lbs.
 Plus .08 lbs. per inch of stroke

F-1500DC2-00A

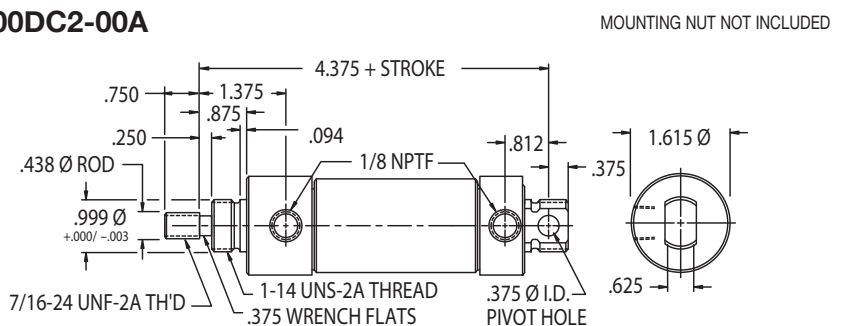

\$51.12 Base Price
Add \$2.46 per inch of stroke

BUMPERS OPTION - ADD .375 TO OAL \$5.13
 MAGNETIC PISTON OPTION - ADD .250 TO OAL \$10.74
 BUMPERS WITH MAGNETIC PISTON OPTIONS - ADD .500 TO OAL



F Series Delrin® Corrosion Resistant Cylinders

MOUNTING NUT NOT INCLUDED

F-1500DC3-00A

1-1/2" Bore Delrin® Series

Double Acting Double Rod

Standard Stroke Lengths:

1/2", 1", 1-1/2", 2", 2-1/2", 3", 4", 5", 6"

Maximum Stroke: 12"

Optional Accessories:

• F-M19S006 Stainless Steel Mounting Nut

Base Weight: .60 lbs.

Plus .13 lbs. per inch of stroke

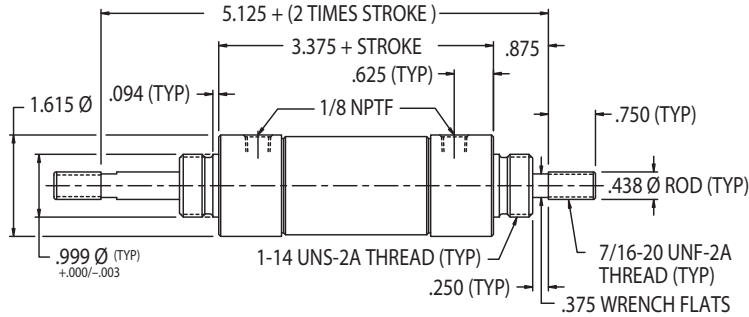

BUMPERS OPTION - ADD .250 TO OAL & BODY LENGTHCF
 MAGNETIC PISTON OPTION - NO CHANGE IN OALCF
 BUMPERS WITH MAGNETIC PISTON - ADD .250 TO OAL & BODY LENGTH

\$79.22 Base Price

Add \$4.07 per inch of stroke

Delrin® Cylinder Specifications – Options & Accessories

- Maximum operating pressure 100psi Air.
- Temperature range +32° to +160°F.
- Piston Rod
Ground and polished, 303 stainless steel is standard.
- Magnetic piston optional on all bore cylinders (except in combination with Viton option).

OPTION	PRICE ADDER
• Viton® Seals – Not available with bumpers or magnetic piston (for media or environment compatibility only)	
DC1 – 3/4 Bore	\$11.10
DC2 – 3/4 Bore	\$11.04
1-1/16 Bore.....	\$13.37
1-1/2 Bore.....	\$14.23
• Pivot Bushing –	Not Available
• Ports Rotated –	Not Available
• Rod Wiper –	Not Available
• Side Port –	Not Available
• Low Temp. Seals	Not Available
• Rod Extension –	
3/4 Bore	\$.74/inch
1-1/16 Bore.....	\$.74/inch
1-1/2 Bore.....	\$1.17/inch
• Rod Thread Extension –	
3/4 Bore	\$1.79/inch
1-1/16 Bore.....	\$1.79/inch
1-1/2 Bore.....	\$2.23/inch

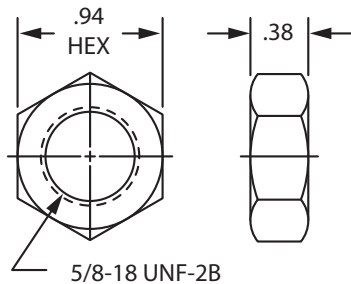

Mounting Nut

F-M19S005 Price: \$4.55
 Max. Recommended Torque 12 in-lbs

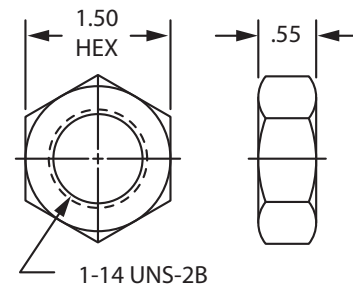

Mounting Nut

F-M19S006 Price: \$8.45
 Max. Recommended Torque 30 in-lbs

F Series Magnetic Interchange



9/16" Bore Cylinders

Double Acting

Front Nose Mount

Standard Stroke Lengths:

1/2", 1", 1-1/2", 2", 2-1/2", 3", 4", 5", 6"

Maximum Stroke: 12"

Optional Accessories:

- F-M117003 Mounting Bracket
- F-M127002 Rod Clevis

Base Weight: .10 lbs.

Plus .01 lbs. per inch of stroke

F-0563DM1-00A

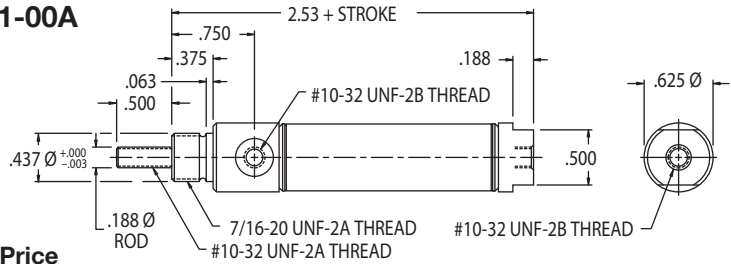

\$26.69 Base Price

Add \$1.54 per inch of stroke

BUMPER OPTION - ADD .125 TO OAL \$4.20

Double Acting

Double Nose or Rear Pivot Mount

Standard Stroke Lengths:

1/2", 1", 1-1/2", 2", 2-1/2", 3", 4", 5", 6", 7", 8", 9", 10", 11", 12"

Maximum Stroke: 12"

Optional Accessories:

- F-M117003 Mounting Bracket
- F-M129002 Pivot Bracket
- F-M127002 Rod Clevis

Base Weight: .10 lbs.

Plus .01 lbs. per inch of stroke

F-0563DM2-00A

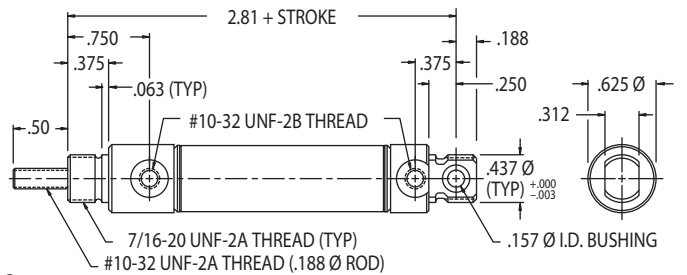

\$30.26 Base Price

Add \$1.54 per inch of stroke

BUMPER OPTION - ADD .125 TO OAL \$4.20

Double Acting

Double Rod

Standard Stroke Lengths:

1/2", 1", 1-1/2", 2", 2-1/2", 3", 4", 5", 6"

Maximum Stroke: 12"

Optional Accessories:

- F-M117003 Mounting Bracket
- F-M127002 Rod Clevis

Base Weight: .14 lbs.

Plus .02 lbs. per inch of stroke

F-0563DM3-00A

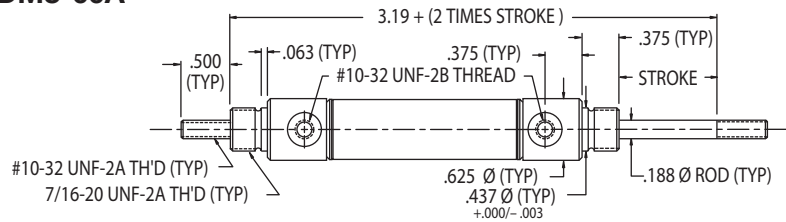

\$37.70 Base Price

Add \$2.11 per inch of stroke

BUMPER OPTION - ADD .125 TO OAL \$2.23

9/16" Bore Cylinder Specifications – Options & Accessories

- -10° to +165°F
- Piston Rod: Ground/Polished 303 Stainless Steel
- **Mounting nuts are not included**
- Bumpers are optional on all 9/16" bore cylinders
- Approximate Force Exerted: (0.25) x (Supply psi)
- Stroke tolerance ±.032

OPTION	PRICE ADDER
• Ports Rotated – 90° on DM2 (both).....	No charge
• Viton® Seals – (for media or environment compatibility only)	
DM1 & DM2	\$10.96
DM3	\$15.47
• Rod Wiper	\$7.10
• Side Port – DM1 (Add .03 to OAL).....	No charge
• Rod Extension DM1, DM2.....	\$.074/inch
• Rod Thread Extension.....	\$.179/inch

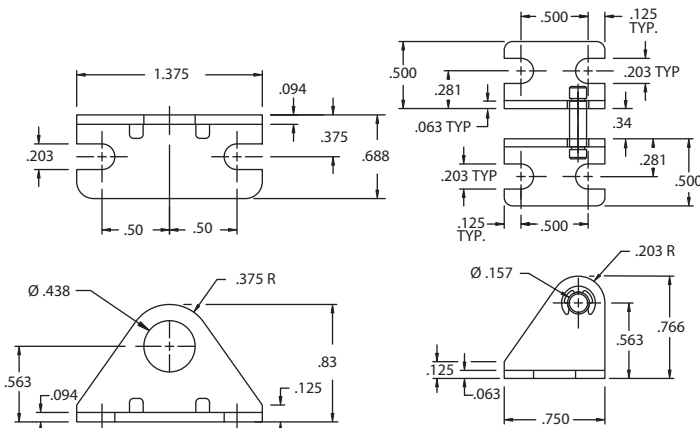

Mounting Bracket

F-M117003
Price: \$1.92

Pivot Bracket

F-M129002
Price: \$5.85

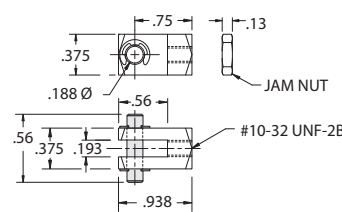

Rod Clevis

F-M127002
Price: \$3.05

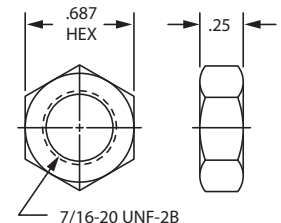

Mounting Nut

F-M190003
Price: \$0.26

F Series Magnetic Interchange 3/4" Bore Cylinders

F- 0750DM1-00A

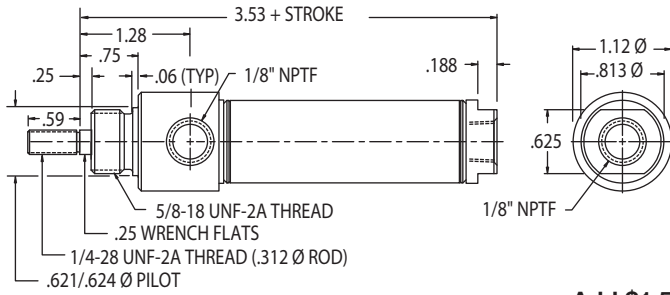

\$27.79 Base Price
Add \$1.54 per inch of stroke

BUMPER OPTION - ADD .250 TO OAL \$4.20

Double Acting

Front Nose Mount

Standard Stroke Lengths:

1/2", 1", 1-1/2", 2", 2-1/2", 3", 4", 5", 6"

Maximum Stroke: 12"

Optional Accessories:

• F-M117005 Mounting Bracket

Base Weight: .24 lbs.

Plus .04 lbs. per inch of stroke

F-0750DM2-00A

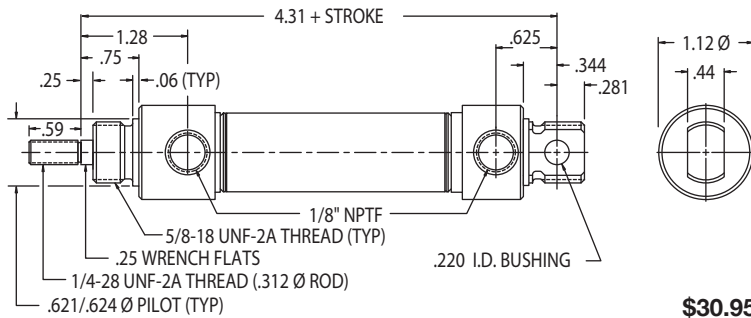

\$30.95 Base Price
Add \$1.54 per inch of stroke

BUMPER OPTION - ADD .250 TO OAL \$4.20

Double Acting

Double Nose or Rear Pivot Mount

Standard Stroke Lengths:

1/2", 1", 1-1/2", 2", 2-1/2", 3", 4",

5", 6", 7", 8", 9", 10", 11", 12"

Maximum Stroke: 32"

Optional Accessories:

• F-M117005 Mounting Bracket

Base Weight: .30 lbs.

Plus .04 lbs. per inch of stroke

F-0750DM3-00A

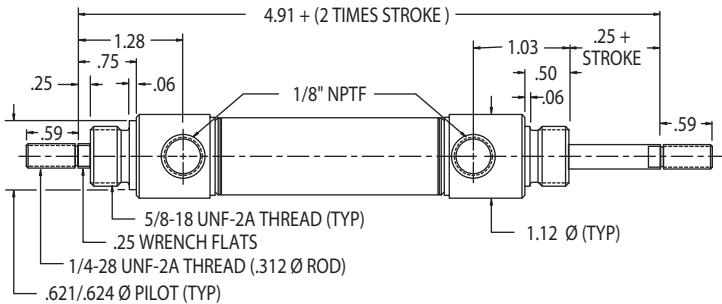

\$41.22 Base Price
Add \$2.11 per inch of stroke

BUMPER OPTION - ADD .250 TO OAL \$1.85

Double Acting

Double Rod

Standard Stroke Lengths:

1/2", 1", 1-1/2", 2", 2-1/2", 3", 4", 5", 6"

Maximum Stroke: 12"

Optional Accessories:

• F-M117005 Mounting Bracket

Base Weight: .41 lbs.

Plus .06 lbs. per inch of stroke

3/4" Bore Cylinder Specifications – Options & Accessories

- -10° to +165°F
- Piston Rod: Ground/Polished 303 Stainless Steel
- **Mounting nuts are not included**
- Bumpers are optional on all 3/4" bore cylinders
- Approximate Force Exerted: (0.4) x (Supply psi)
- Stroke tolerance ±.032

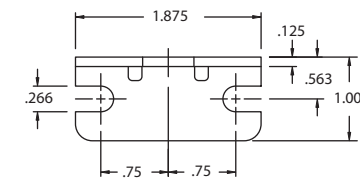

Mounting Bracket

F-M117005

Price: \$2.55

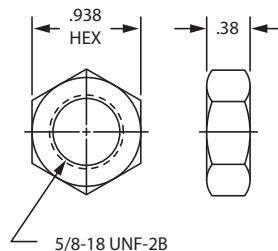

Mounting Nut

F-M190005

Price: \$0.39

OPTION	PRICE ADDER
• Ports Rotated – 90° on DM2 (both).....	No charge
• Viton® Seals – (for media or environment compatibility only)	
DM1 & DM2	\$10.96
DM3	\$15.41
• Rod Wiper	\$7.10
• Side Port – DM1 (Add .44 to OAL).....	No charge
• Rod Extension DM1, DM2.....	\$0.74/inch
• Rod Thread Extension.....	\$1.79/inch

F Series Magnetic Interchange

1-1/16" Bore Cylinders



Double Acting

Front Nose Mount

Standard Stroke Lengths:

1/2", 1", 1-1/2", 2", 2-1/2", 3", 4", 5", 6"

Maximum Stroke: 12"

Optional Accessories:

- F-M127004 Rod Clevis

Base Weight .37 lbs.

Plus .05 lbs. per inch of stroke

F-1062DM1-00A

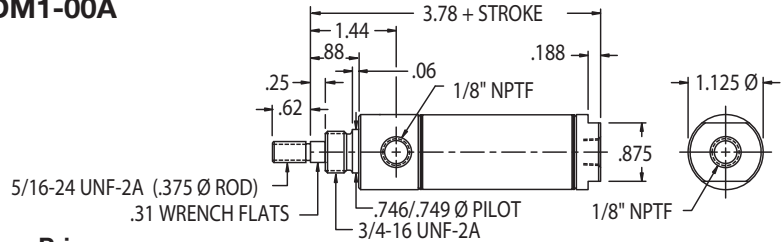

\$33.46 Base Price

Add \$1.54 per inch of stroke

BUMPER OPTION - ADD .250 TO OAL \$4.20

Double Acting

Double Nose or Rear Pivot Mount

Standard Stroke Lengths:

1/2", 1", 1-1/2", 2", 2-1/2", 3", 4",

5", 6", 7", 8", 9", 10", 11", 12"

Maximum Stroke: 32"

Optional Accessories:

- F-M127004 Rod Clevis

Base Weight .42 lbs.

Plus .05 lbs. per inch of stroke

F-1062DM2-00A

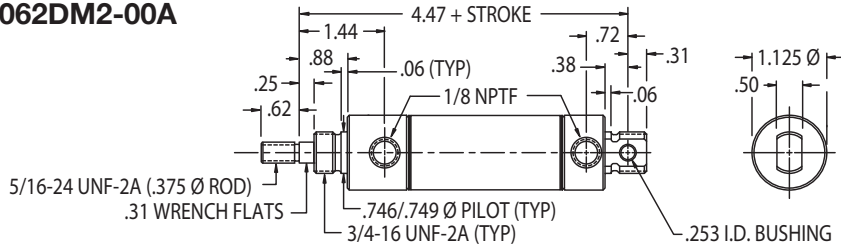

\$37.05 Base Price

Add \$1.54 per inch of stroke

BUMPER OPTION - ADD .250 TO OAL \$4.20

Double Acting

Double Rod

Standard Stroke Lengths:

1/2", 1", 1-1/2", 2", 2-1/2", 3", 4", 5", 6"

Maximum Stroke: 12"

Optional Accessories:

- F-M127004 Rod Clevis

Base Weight: .60 lbs.

Plus .08 lbs. per inch of stroke

F-1062DM3-00A

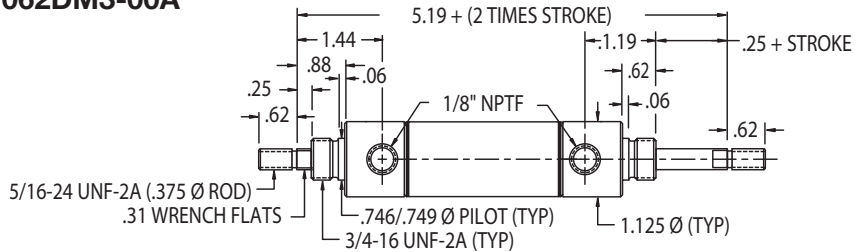

\$44.23 Base Price

Add \$2.11 per inch of stroke

BUMPER OPTION - ADD .250 TO OAL \$4.20

1-1/16" Bore Cylinder Specifications – Options & Accessories

- -10° to +165°F
- Piston Rod: Ground/Polished 303 Stainless Steel
- **Mounting nuts are not included**
- Bumpers are optional on all 1-1/16" bore cylinders
- Approximate Force Exerted: (0.9) x (Supply psi)
- Stroke tolerance ±.032

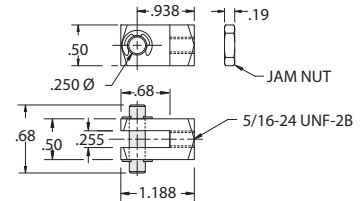
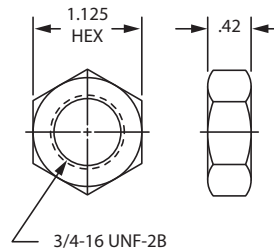

Mounting Nut

F-M190006

Price: \$0.51

Rod Clevis

F-M127004

Price: \$3.51

OPTION	PRICE ADDER
• Ports Rotated - 90° on DM2 (both).....	No charge
• Viton® Seals - (for media or environment compatibility only)	
DM1 & DM2	\$13.26
DM3	\$17.76
• Rod Wiper	\$7.10
• Side Port - DM1 (Add .25 to OAL).....	No charge
• Rod Extension DM1, DM2.....	\$.074/inch
• Rod Thread Extension.....	\$1.79/inch/end



F Series Magnetic Interchange 1-1/4" Bore Cylinders

F-1250DM1-00A

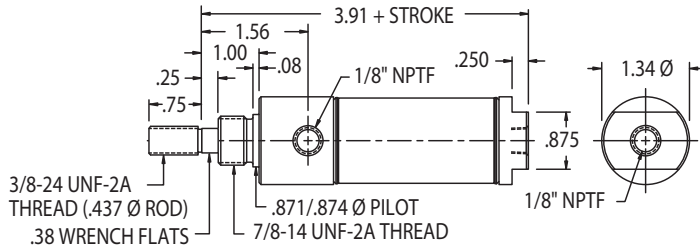

BUMPER OPTION - ADD .250 TO OAL\$4.92

\$41.72 Base Price
Add \$2.11 per inch of stroke

Double Acting

Front Nose Mount

Standard Stroke Lengths:

1/2", 1", 1-1/2", 2", 2-1/2", 3", 4", 5", 6"

Maximum Stroke: 12"

Optional Accessories:

• F-M117013 Mounting Bracket

Base Weight: .51 lbs.

Plus .07 lbs. per inch of stroke

F-1250DM2-00A

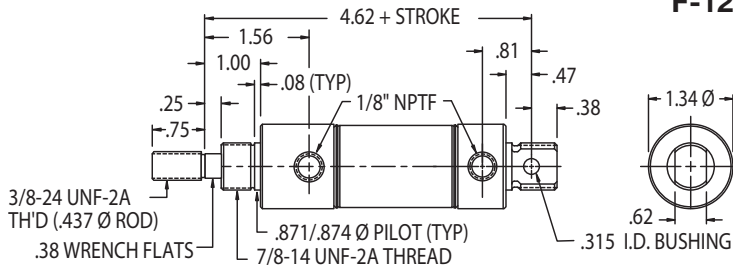

BUMPER OPTION - ADD .250 TO OAL\$4.92

\$46.39 Base Price
Add \$2.11 per inch of stroke

Double Acting

Double Nose or Rear Pivot Mount

Standard Stroke Lengths:

1/2", 1", 1-1/2", 2", 2-1/2", 3", 4",

5", 6", 7", 8", 9", 10", 11", 12"

Maximum Stroke: 32"

Optional Accessories:

• F-M117013 Mounting Bracket

Base Weight: .61 lbs.

Plus .07 lbs. per inch of stroke

F-1250DM3-00A

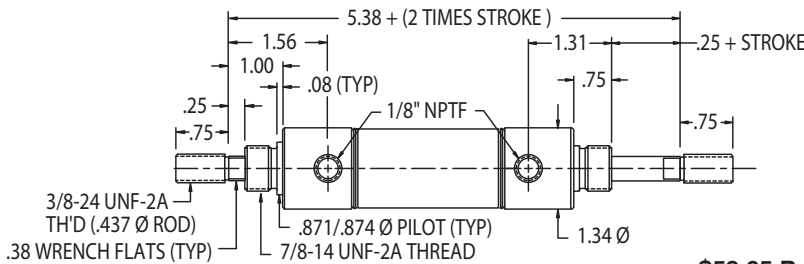

BUMPER OPTION - ADD .250 TO OAL\$1.48

\$58.65 Base Price
Add \$3.09 per inch of stroke

Double Acting

Double Rod

Standard Stroke Lengths:

1/2", 1", 1-1/2", 2", 2-1/2", 3", 4", 5", 6"

Maximum Stroke: 12"

Optional Accessories:

• F-M117013 Mounting Bracket

Base Weight: .70 lbs.

Plus .14 lbs. per inch of stroke

1-1/4" Bore Cylinder Specifications – Options & Accessories

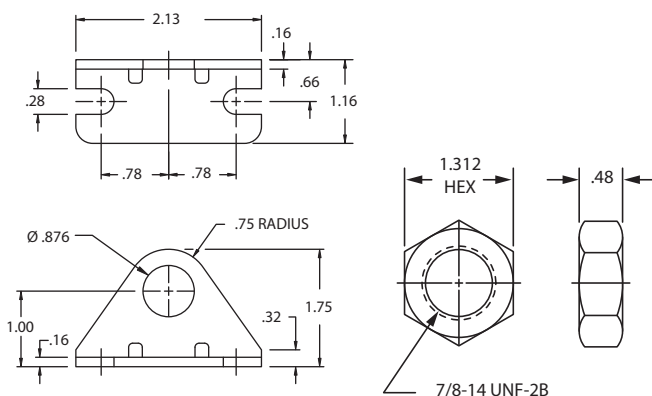

Mounting Bracket
F-M117013
Price: \$8.74

Mounting Nut
F-M190007
Price: \$1.58

OPTION

PRICE ADDER

- Ports Rotated – 90° on DM2 (both).....No charge
- Viton® Seals – (for media or environment compatibility only)
 - DM1 & DM2 \$13.37
 - DM3 \$19.84
- Rod Wiper – \$7.10
- Side Port – DM1 (Add .25 to OAL).....No charge
- Rod Extension DM1, DM2.....\$0.99/inch
- Rod Thread Extension..... \$2.03/inch/end

- -10° to +165°F
- Piston Rod: Ground/Polished 303 Stainless Steel
- **Mounting nuts are not included**
- Bumpers are optional on all 1-1/4" bore cylinders
- Approximate Force Exerted: (1.2) x (Supply psi)
- Stroke tolerance ±.032

F Series Magnetic Interchange

1-1/2" Bore Cylinders



Double Acting

Front Nose Mount

Standard Stroke Lengths:

1/2", 1", 1-1/2", 2", 2-1/2", 3", 4", 5", 6"

Maximum Stroke: 12"

Optional Accessories:

- F-M127005 Rod Clevis

Base Weight: .74 lbs.

Plus .10 lbs. per inch of stroke

F-1500DM1-00A

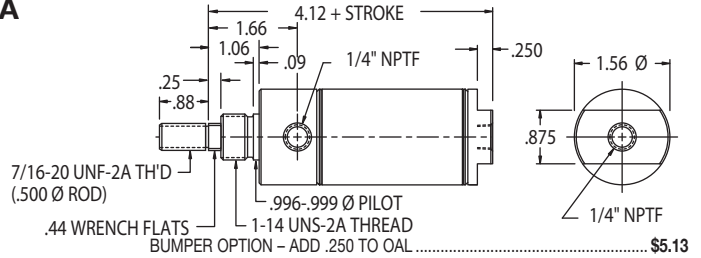

\$49.65 Base Price

Add \$2.46 per inch of stroke

Double Acting

Double Nose or Rear Pivot Mount

Standard Stroke Lengths:

1/2", 1", 1-1/2", 2", 2-1/2", 3", 4", 5", 6", 7", 8", 9", 10", 11", 12"

Maximum Stroke: 32"

Optional Accessories:

- F-M127005 Rod Clevis

Base Weight: .87 lbs.

Plus .10 lbs. per inch of stroke

F-1500DM2-00A

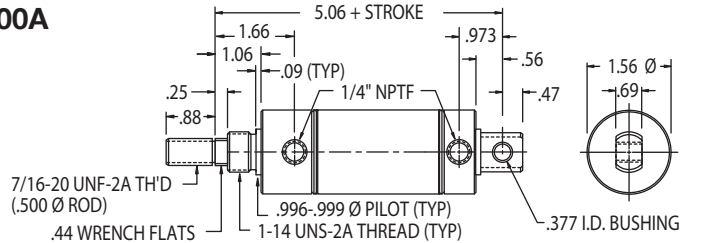

\$54.22 Base Price

Add \$2.46 per inch of stroke

BUMPER OPTION - ADD .250 TO OAL \$5.13

Double Acting Double Rod

Standard Stroke Lengths:

1/2", 1", 1-1/2", 2", 2-1/2", 3", 4", 5", 6"

Maximum Stroke: 12"

Optional Accessories:

- F-M127005 Rod Clevis

Base Weight: .94 lbs.

Plus .20 lbs. per inch of stroke

F-1500DM3-00A

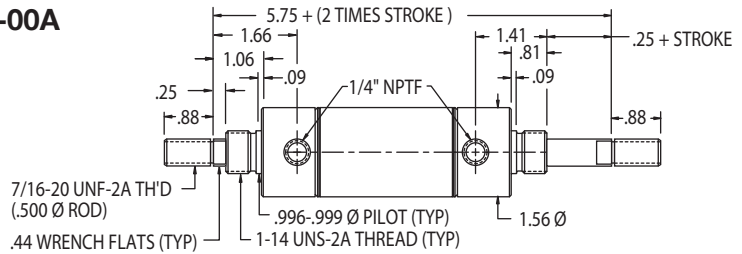

\$62.54 Base Price

Add \$4.01 per inch of stroke

BUMPER OPTION - ADD .250 TO OAL \$3.26

1-1/2" Bore Cylinder Specifications – Options & Accessories

- -10° to +165°F
- Piston Rod: Ground/Polished 303 Stainless Steel
- **Mounting nuts are not included**
- Bumpers are optional on all 1-1/2" bore cylinders
- Approximate Force Exerted: (1.7) x (Supply psi)
- Stroke tolerance ±.032

OPTION	PRICE ADDER
• Ports Rotated – 90° on DM2 (both).....	No charge
• Viton® Seals – (for media or environment compatibility only)	
DM1 & DM2	\$18.11
DM3	\$19.22
• Rod Wiper –	\$7.10
• Side Port – DM1 (Add .25 to OAL).....	No charge
• Rod Extension DM1, DM2.....	\$1.17/inch
• Rod Thread Extension.....	\$2.23/inch/end

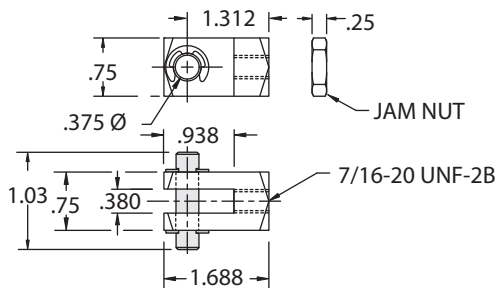

Rod Clevis
F-M127005
Price: \$5.80

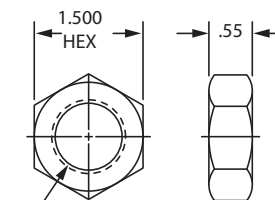

Mounting Nut
F-M190008
Price: \$2.36



F Series Magnetic Interchange 1-3/4" Bore Cylinders

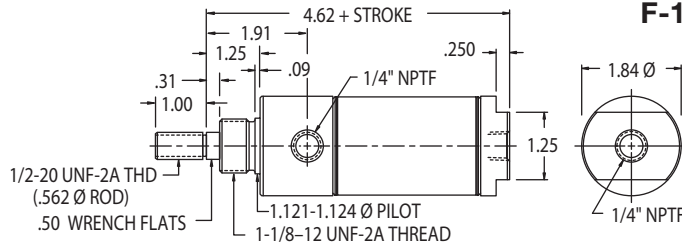

F-1750DM1-00A

BUMPER OPTION - ADD .250 TO OAL \$6.36

\$57.24 Base Price
Add \$2.46 per inch of stroke

Double Acting
Front Nose Mount
Standard Stroke Lengths:
1/2", 1", 1-1/2", 2", 2-1/2", 3", 4", 5", 6"
Maximum Stroke: 12"
Optional Accessories:
• F-M117012 Mounting Bracket
• F-M127006 Rod Clevis
Base Weight: 1.14 lbs.
Plus .13 lbs. per inch of stroke

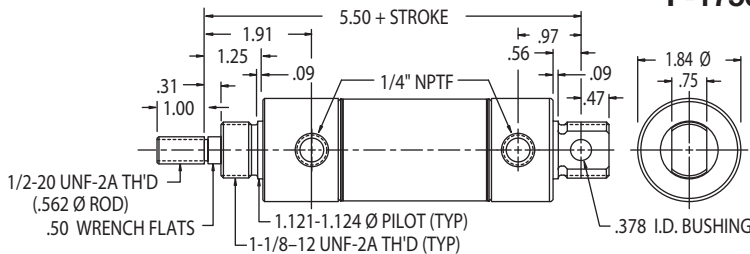

F-1750DM2-00A

BUMPER OPTION - ADD .250 TO OAL \$6.36

\$62.96 Base Price
Add \$2.46 per inch of stroke

Double Acting
Double Nose or Rear Pivot Mount
Standard Stroke Lengths:
1/2", 1", 1-1/2", 2", 2-1/2", 3", 4", 5", 6", 7", 8", 9", 10", 11", 12"
Maximum Stroke: 32"
Optional Accessories:
• F-M117012 Mounting Bracket
• F-M127006 Rod Clevis
Base Weight: 1.30 lbs.
Plus .13 lbs. per inch of stroke

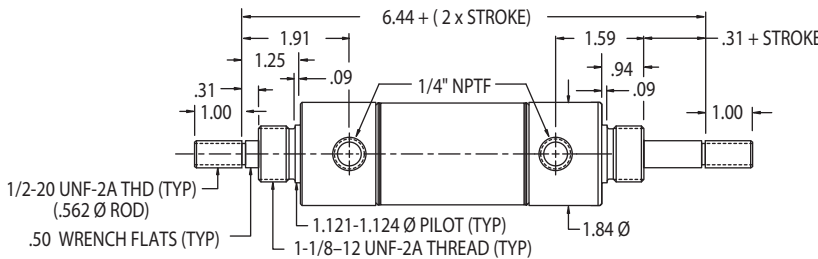

F-1750DM3-00A

BUMPER OPTION - ADD .250 TO OAL \$6.23

\$78.80 Base Price
Add \$4.01 per inch of stroke

Double Acting
Double Rod
Standard Stroke Lengths:
1/2", 1", 1-1/2", 2", 2-1/2", 3", 4", 5", 6"
Maximum Stroke: 12"
Optional Accessories:
• F-M117012 Mounting Bracket
• F-M127006 Rod Clevis
Base Weight: 1.40 lbs.
Plus .26 lbs. per inch of stroke

1-3/4" Bore Cylinder Specifications – Options & Accessories

- -10° to +165°F
- Piston Rod: Ground/Polished 303 Stainless Steel
- **Mounting nuts are not included**
- Bumpers are optional on all 1-3/4" bore cylinders
- Approximate Force Exerted: (2.4) x (Supply psi)
- Stroke tolerance ±.032

OPTION	PRICE ADDER
• Ports Rotated - 90° on DM2 (both)	No charge
• Viton® Seals - (for media or environment compatibility only)	
DM1 & DM2	\$18.86
DM3	\$18.24
• Rod Wiper -	\$7.10
• Side Port - DM1 (Add .56 to OAL)	No charge
• Rod Extension DM1, DM2	\$1.17/inch
• Rod Thread Extension	\$.23/inch/end

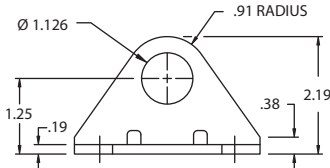
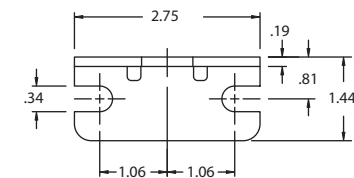

Mounting Bracket
F-M117012
Price: \$18.60

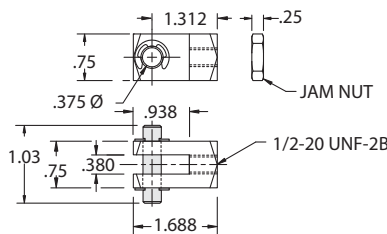

Rod Clevis
F-M127006
Price: \$5.80

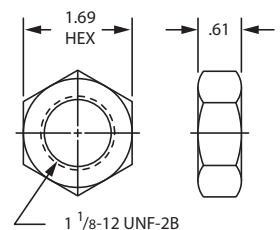

Mounting Nut
F-M190015
Price: \$4.45

F Series Magnetic Interchange 2" Bore Cylinders



Double Acting

Front Nose Mount

Standard Stroke Lengths:

1/2", 1", 1-1/2", 2", 2-1/2", 3", 4", 5', 6"

Maximum Stroke: 12"

Optional Accessories:

- F-M127006 Rod Clevis

Base Weight: 1.55 lbs.

Plus .15 lbs. per inch of stroke

F-2000DM1-00A

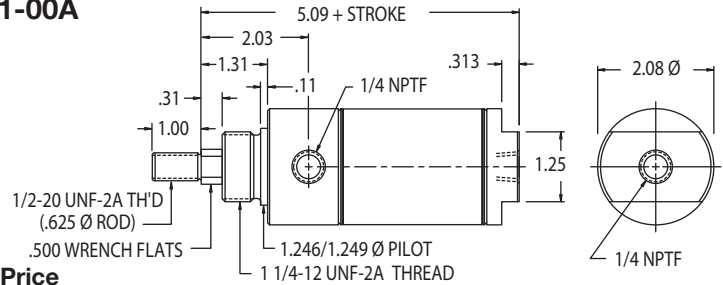

\$64.64 Base Price

Add \$2.84 per inch of stroke

BUMPER OPTION - ADD .250 TO OAL \$6.61

Double Acting

Double Nose or Rear Pivot Mount

Standard Stroke Lengths:

1/2", 1", 1-1/2", 2", 2-1/2", 3", 4",

5", 6", 7", 8", 9", 10", 11", 12"

Maximum Stroke: 32"

Optional Accessories:

- F-M127006 Rod Clevis

Base Weight: 1.80 lbs.

Plus .15 lbs. per inch of stroke

F-2000DM2-00A

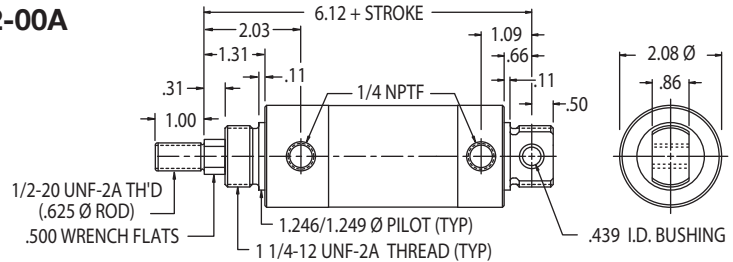

\$71.04 Base Price

Add \$2.84 per inch of stroke

BUMPER OPTION - ADD .250 TO OAL \$6.53

Double Acting

Double Rod

Standard Stroke Lengths:

1/2", 1", 1-1/2", 2", 2-1/2", 3", 4", 5", 6"

Maximum Stroke: 12"

Optional Accessories:

- F-M127006 Rod Clevis

Base Weight: 1.90 lbs.

Plus .30 lbs. per inch of stroke

F-2000DM3-00A

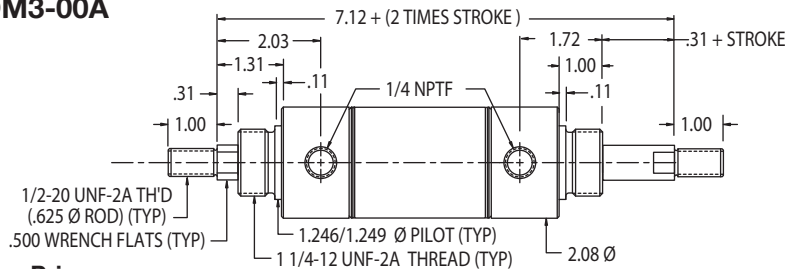

\$84.57 Base Price

Add \$4.13 per inch of stroke

BUMPER OPTION - ADD .250 TO OAL \$6.96

2" Bore Cylinder Specifications – Options & Accessories

- -10° to +165°F
- Piston Rod: Ground/Polished 303 Stainless Steel
- **Mounting nuts are not included**
- Bumpers are optional on all 2" bore cylinders
- Approximate Force Exerted: (3.1) x (Supply psi)
- Stroke tolerance ±.032

OPTION	PRICE ADDER
• Ports Rotated - 90° on DM2 (both).....	No charge
• Viton® Seals - (for media or environment compatibility only)	
DM1 & DM2	\$18.62
DM3	\$26.18
• Rod Wiper -	\$7.10
• Side Port - DM1 (Add .56 to OAL).....	No charge
• Rod Extension DM1, DM2.....	\$1.54/inch
• Rod Thread Extension.....	\$ 2.60/inch/end

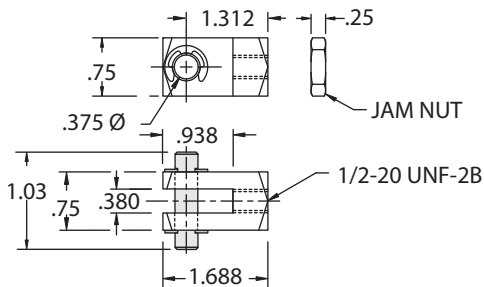

Rod Clevis
F-M127006
Price: \$5.80

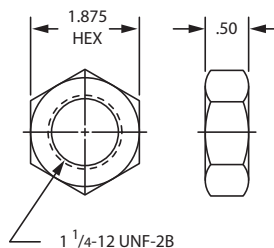

Mounting Nut
F-M190009
Price: \$3.64

F Series Magnetic Interchange 2-1/2" Bore Cylinders

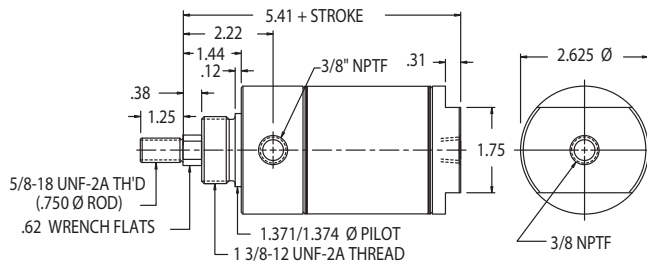

F-2500DM1-00A

Double Acting
Front Nose Mount
Standard Stroke Lengths:
1/2", 1", 1-1/2", 2", 2-1/2", 3", 4", 5", 6
Maximum Stroke: 12"
Optional Accessories:
• F-M127007 Rod Clevis
Base Weight: 2.48 lbs.
Plus .20 lbs. per inch of stroke

BUMPER OPTION - ADD .250 TO OAL \$24.29 **Add \$3.09 per inch of stroke**

F-2500DM2-00A

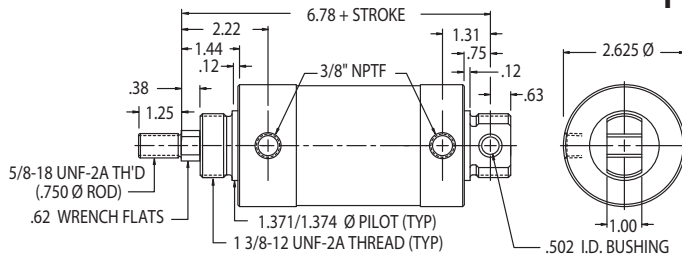

Double Acting
Double Nose or Rear Pivot Mount
Standard Stroke Lengths:
1/2", 1", 1-1/2", 2", 2-1/2", 3", 4", 5", 6", 7", 8", 9", 10", 11", 12"
Maximum Stroke: 32"
Optional Accessories:
• F-M127007 Rod Clevis
Base Weight: 2.90 lbs.
Plus .20 lbs. per inch of stroke

BUMPER OPTION - ADD .250 TO OAL \$24.29 **Add \$3.09 per inch of stroke**

F-2500DM3-00A

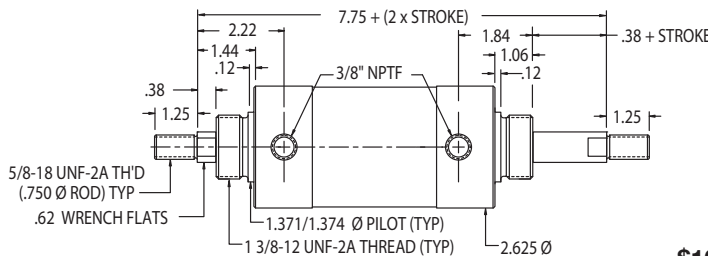

Double Acting
Double Rod
Standard Stroke Lengths:
1/2", 1", 1-1/2", 2", 2-1/2", 3", 4", 5", 6"
Maximum Stroke: 12"
Optional Accessories:
• F-M127007 Rod Clevis
Base Weight: 3.15 lbs.
Plus .40 lbs. per inch of stroke

BUMPER OPTION - ADD .250 TO OAL \$24.29 **Add \$4.86 per inch of stroke**

2-1/2" Bore Cylinder Specifications – Options & Accessories

- -10° to +165°F
- Piston Rod: Ground/Polished 303 Stainless Steel
- **Mounting nuts are not included**
- Bumpers are optional on all 2-1/2" bore cylinders
- Approximate Force Exerted: (5.0) x (Supply psi)
- Stroke tolerance ± .032

OPTION	PRICE ADDER
• Ports Rotated - 90° on DM2 (both).....	No charge
• Viton® Seals - (for media or environment compatibility only)	
DM1	\$22.68
DM2	\$22.63
DM3	\$33.95
• Rod Wiper -	\$7.10
• Side Port - DM1. (Add .38 to OAL)	No charge
• Rod Extension DM1, DM2.....	\$.154/inch
• Rod Thread Extension.....	\$ 2.60/inch/end

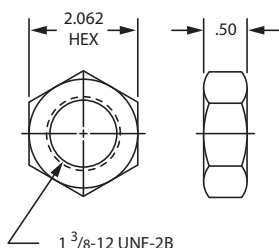

Mounting Nut
F-M190012
Price: \$5.74

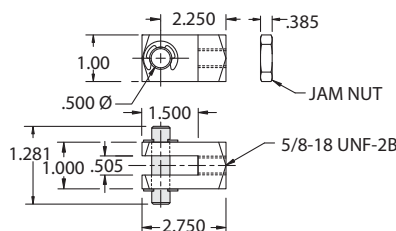

Rod Clevis
F-M127007
Price: \$15.50

F Series

3-Position (Tandem) Cylinders



Tandem cylinders are generally used when three distinct rod positions are required from a single cylinder body. Two cylinders are assembled tip-to-tail with a common center head. Using cylinders with two different lengths (the shorter located on the rear cylinder), enables the front rod to be extended from "home" to a positive mid-position or to full extension.

How they work

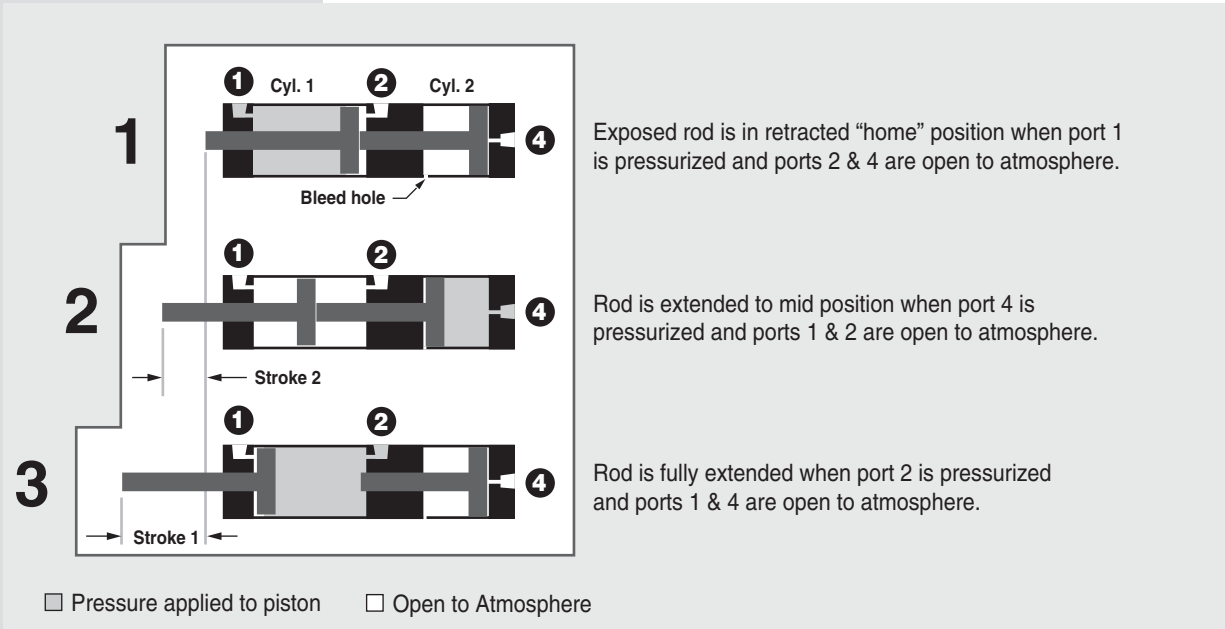

How to Order

Bore Mounting
F-1500 D1

Bore Size (4 digits)
 0750 = 3/4"
 1062 = 1-1/16"
 1500 = 1-1/2"
 2000 = 2"

Mounting Style (2 digits)
 D1 = Double Acting Nose Mount

Stroke 1 Stroke 2 Options
- 06A - 04A - 12

Cyl. 2 Stroke
Cyl. 1 Stroke

Options (2 digits)
 12 = Magnetic Piston both ends
 Leave blank if magnetic piston is not required

In the order example above, when port 4 is pressurized, the cylinder will stroke 4". When port 2 is pressurized, the cylinder will stroke an additional 2" for a total of 6".

For cylinder 2 strokes over 8" and/or combined strokes over 24", consult factory.

Stroke Tolerance	
3/4" thru 1-1/2" bore	+0.075 / -0.040
2" bore	+0.095 / -0.060

Full Inch Stroke (2 digits)	
00	= 0"
01	= 1"
02	= 2"
03	= 3"
.	
.	
08	= 8" (max. cyl. 2 stroke)

Note:
 Total Stroke 1 + Stroke 2 not to exceed 24"

Fractional Inch Stroke	
(1 digit)	
A	= 0"
I	= 1/2"

F Series 3-Position Cylinders

F-0750D1-00A-00A-00

3/4" Bore
Front Nose Mount

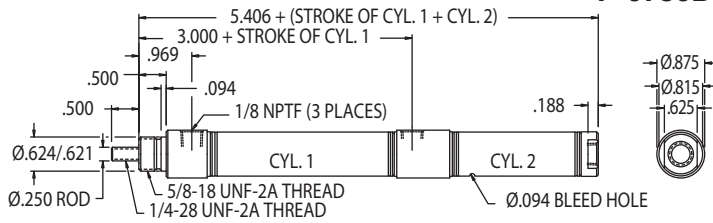

\$37.62 Base Price

Add \$1.61 per inch of stroke (Total stroke 1 + stroke 2)

Add \$11.85 for Magnetic Band Option (-12)

Available Stroke Lengths:
 Cyl. 2 – 1/2" increments to 8"
 Cyl. 1 – 1/2" increments
 Total stroke 1 + stroke 2 not to exceed 24"

Optional Accessories:
 • M117005 Mounting Bracket
 See details page 63

F-1062D1-00A-00A-00

1-1/16" Bore
Front Nose Mount

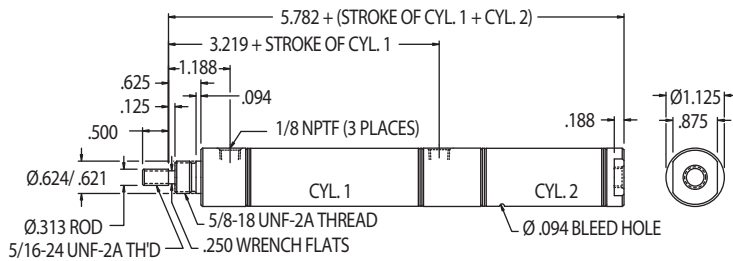

\$43.43 Base Price

Add \$1.61 per inch of stroke (Total stroke 1 + stroke 2)

Add \$13.40 for Magnetic Band Option (-12)

Available Stroke Lengths:
 Cyl. 2 – 1/2" increments to 8"
 Cyl. 1 – 1/2" increments
 Total stroke 1 + stroke 2 not to exceed 24"

Optional Accessories:
 • M117005 Mounting Bracket
 See details page 63

F-1500D1-00A-00A-00

1-1/2" Bore
Front Nose Mount

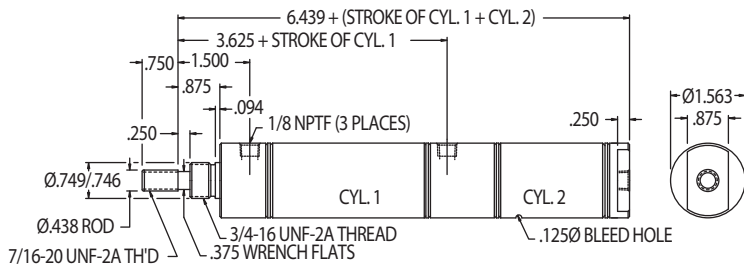

\$58.91 Base Price

Add \$2.51 per inch of stroke (Total stroke 1 + stroke 2)

Add \$14.96 for Magnetic Band Option (-12)

Available Stroke Lengths:
 Cyl. 2 – 1/2" increments to 8"
 Cyl. 1 – 1/2" increments
 Total stroke 1 + stroke 2 not to exceed 24"

Optional Accessories:
 • M117007 Mounting Bracket
 See details page 63

F-2000D1-00A-00A-00

2" Bore Standard
Front Nose Mount

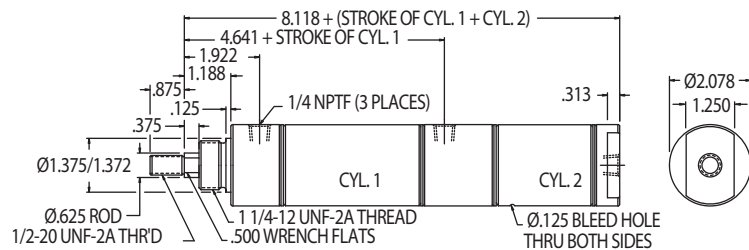

\$81.58 Base Price

Add \$2.88 per inch of stroke (Total stroke 1 + stroke 2)

Add \$22.84 for Magnetic Band Option (-12)

Available Stroke Lengths:
 Cyl. 2 – 1/2" increments to 8"
 Cyl. 1 – 1/2" increments
 Total stroke 1 + stroke 2 not to exceed 24"

Optional Accessories:
 • M117009 Mounting Bracket
 See details page 63

F Series

Hole Punch Cylinders

Fabco-Air's rugged Hole Punch Cylinder enables trouble-free punching of millions of holes in plastic film; ideally suited for LLDPE (linear low density polyethylene). A major feature allows punch replacement without having to replace the cylinder. Available in eight different hole punch sizes from 1/8" to 3/4," razor sharp plastic punches are self-sharpening and significantly outlast conventional steel punches in most applications.

An air ejector, foam ejector, and auto ejector are offered as options. These ejectors discharge material slugs from the center of the punch and prevent debris build-up.

Punches may be used with any F Series cylinder that has 1/4-28 UNF-2A male threads. For your convenience, Fabco-Air has configured three standard cylinders designed specifically for hole punch applications. A thread extension of 1/2" aids punch position adjustment. Elastomer bumpers are included to ensure quiet operation. The cylinders are rated for 250 psi. A mounting nut is included.



Stroke Tolerance $\pm .032$

3/4" Bore Single Acting Spring Return 1/2" Stroke

- Bumpers
- 1/2" Thread Extension
- Mounting Nut Included

FM12263-001
Price: \$21.96

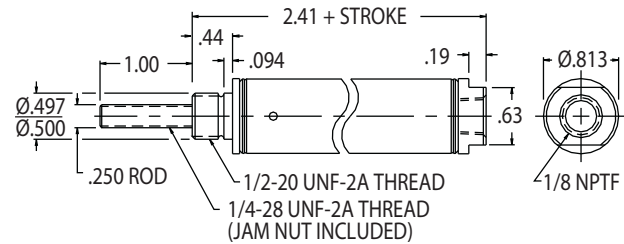

3/4" Bore Single Acting Spring Return 1" Stroke

- Bumpers
- 1/2" Thread Extension
- Mounting Nut Included

FM12263-01A
Price: \$21.96

3/4" Bore Single Acting Spring Return 1/2" Stroke – Non-Rotating Rod

- Bumpers
- 1/2" Thread Extension
- Mounting Nut Included

FM12264-001
Price: \$27.79

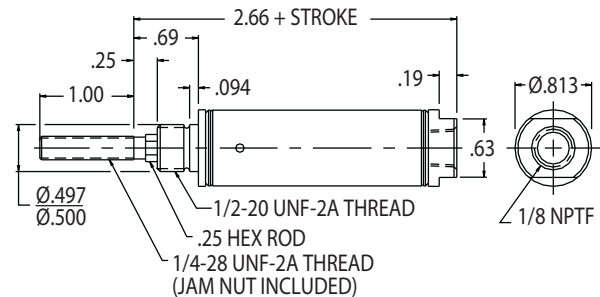

3/4" Bore Single Acting Spring Return 1" Stroke – Non-Rotating Rod

- Bumpers
- 1/2" Thread Extension
- Mounting Nut Included

FM12264-01A
Price: \$27.79

3/4" Bore Single Acting Spring Return 1/2" Stroke – Hollow Rod for air ejector applications

- Bumpers
- 1/2" Thread Extension
- Mounting Nut Included

FM12265-001
Price: \$34.42

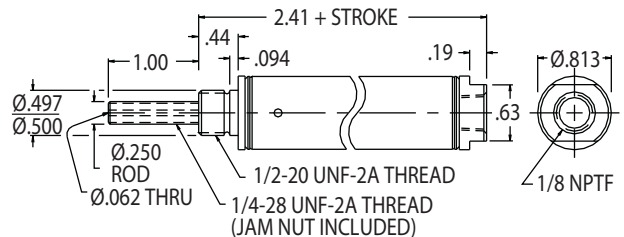

3/4" Bore Single Acting Spring Return 1" Stroke – Hollow Rod for air ejector applications

- Bumpers
- 1/2" Thread Extension
- Mounting Nut Included

FM12265-01A
Price: \$34.42

**Punch for Hole
 Diameters 1/8" and 1/4"
 shown below with
 #F-AB-1A Adapter**

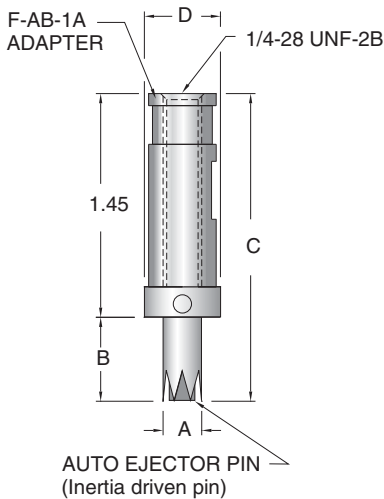

**Punch for Hole
 Diameters 3/8" - 3/4"**

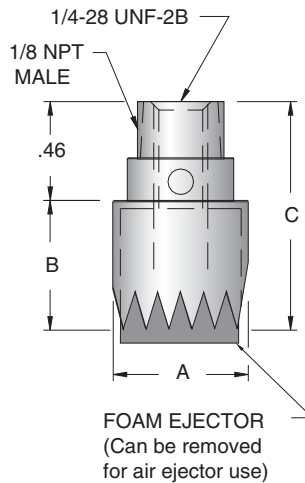

Benefits

- Punches are replaceable without replacing cylinder.
- Punches are self sharpening, light weight plastic. Made from specially formulated material, these punches regularly outlast steel punches in most applications.
- Auto-Ejector is standard on 1/8" and 1/4" diameters.
- Foam ejector is standard on 3/8" to 3/4" diameters.
- Punch locations are adjustable along cylinder rod.
- Excellent for use in:
 - Linear Low Density Polyethylene Film (LLDPE)
 - Polyethylene film up to 3 mil thickness
 - Polypropylene film up to 1 mil thickness

Part #	Hole Dia.	A	B	C	D	Ejector Type	Adapter Required	†Package Price
F-PCN-18	1/8"	.125	.54	1.99	.44	Auto Ejector Pin	F-AB-1A (\$27.11 ea.)	\$57.39
F-PCN-14	1/4"	.250	.54	1.99	.44	Auto Ejector Pin	F-AB-1A (\$27.11 ea.)	55.47
F-PCN-38	3/8"	.375	.54	1.00	NA	Foam Ejector	None	94.31
F-PCN-716	7/16"	.437	.54	1.00	NA	Foam Ejector	None	55.47
F-PCN-12	1/2"	.500	.54	1.00	NA	Foam Ejector	None	55.47
F-PCN-916	9/16"	.562	.60	1.06	NA	Foam Ejector	None	63.62
F-PCN-58	5/8"	.625	.60	1.06	NA	Foam Ejector	None	63.62
F-PCN-34	3/4"	.750	.60	1.06	NA	Foam Ejector	None	80.08

Note:

1. Punch standard package quantity is 5 pieces.
2. Adapters are available individually, and are not supplied with the punch.
3. For air ejection applications, use hollow rod cylinders type FM12265.
4. Jam nuts are included with all "Hole Punch" cylinders.

Cylinder and Punch Assemblies

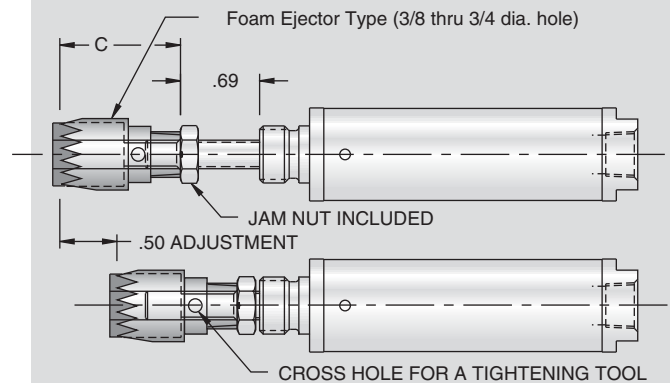
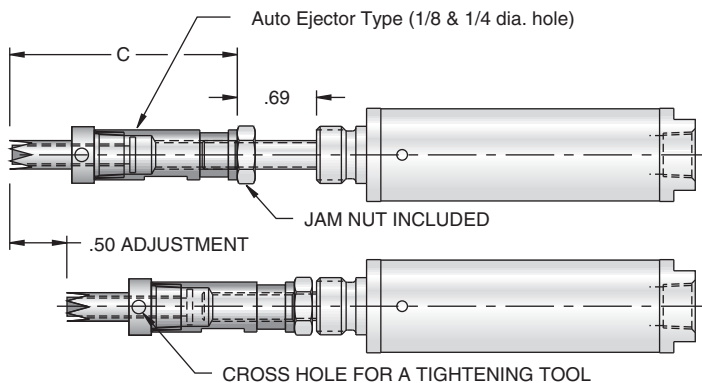

PFA Series

Position Feedback Cylinders



General Technical Data

The **PFA Series** is an economical pneumatic linear actuator that contains an internal Linear Resistive Transducer (LRT). It is ideal for applications where traditional magnetic position sensing is not acceptable. Additionally, the **PFA Series** is conducive where variations in cylinder stroke and speed are required or where an application calls for continuous position monitoring.

- Operating pressure: 150 psi max.
- Recommended Media: Filtered, clean, dry "non-condensing" compressed air. Do not apply any fluids that may be electrically conductive. Water-based fluids should not be used.

Electrical Specifications

Electrical Resistance	1000 ohms (± 20%) per inch of stroke
Resolution	Infinite (limited by interfacing electronics)
Temperature Range	0° F to 160° F
Life Rating	500 million inches of travel on transducer
Linearity	±1% of stroke (or better)
Interface	6" cable with M8x1 Quick Connect
Signal Input	Typically 10 VDC
Maximum Speed	50 in/sec
Maximum Standard Stroke	18 inches (longer strokes available upon request)
Maximum Current	1 microamp required from the transducer

Note: Control Module Units sold separately can have scalable output of 4-20 mA or 0-10 VDC and input of 120 VAC or 12-24 VDC. See pages 58 and 59.

LRT Circuit Diagram

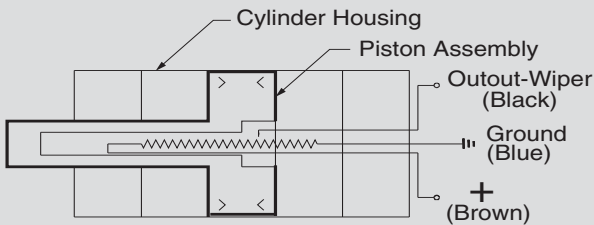

Connector Pin Assignments

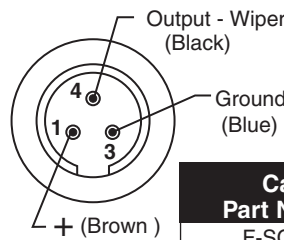

Cable Part Number	Description	List Price
F-SC6-001	3m (10') Non shielded	\$28.46
F-N99-1109	5m (16.4') Shielded	\$50.39

How to Order Cylinder

F - 10 AM 1 - 06 A 01 - [] [] [] [] []

Basic Series
Cylinder Bore
 10 = 1-1/16"
 15 = 1-1/2"
 20 = 2"
 25 = 2-1/2"
 30 = 3"

Cylinder Type
 AM = PFA Series

Cylinder Mounting
 1 = Front Nose
 2 = Rear Pivot

"Standard" Full Inches of Stroke
 01 = 1" Stroke 06 = 6" Stroke
 02 = 2" Stroke 08 = 8" Stroke
 03 = 3" Stroke 12 = 12" Stroke
 04 = 4" Stroke 18 = 18" Stroke (Max. Available)

Note: Non-standard stroke lengths will increase lead time.

Rod and/or Thread Extension
 1A ___ = Rod Extension (Code is 1A plus 3 digits)
 Example: 1A01A = 1" + no fractional inch ext'n.
 2A ___ = Thread Extension (Code is 2A plus 3 digits)
 Example: 2A01E = 1-1/4" extension.
 RT ___ = Rod and Thread Extension (Code is RT plus 6 digits; specify rod extension first)
 Example: RT02A01M = 2" rod & 1-3/4" thread ext'n.

Options
 00 = No Options (or leave blank)
 01 = Bumpers

Fractional Inches of Stroke
 A = 0"
 I = 1/2"

Note that the **PFA Series** can integrate with some Fabco-Air slide products. Contact your local distributor or Fabco-Air engineering for details.

PFA Series Position Feedback Cylinders

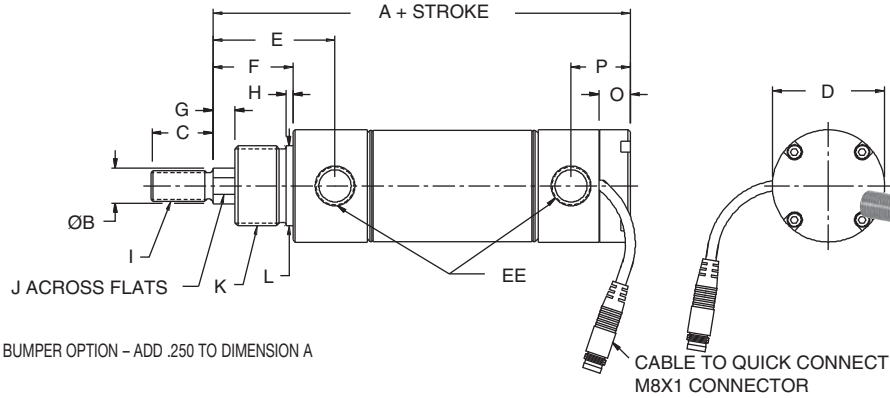

Front Nose Mount - 150 psi Max.
Cylinder Type AM1
 Rod wiper is standard.
 Mounting nut is not included.



See page 63 for accessory details.

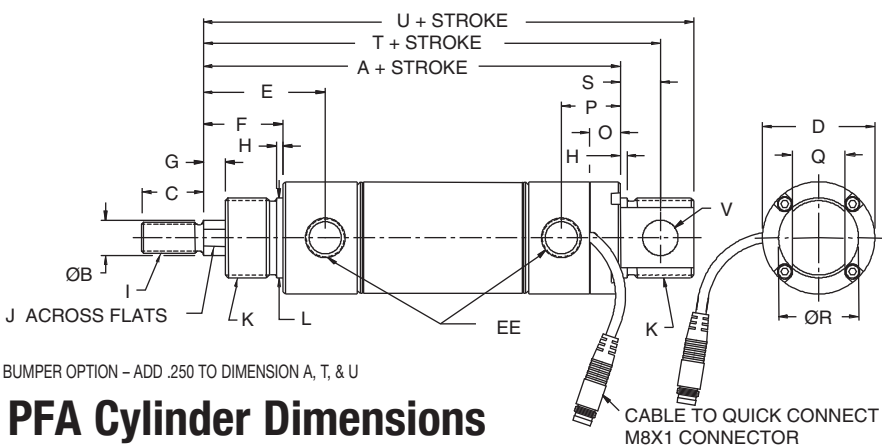

Rear Pivot Mount - 150 psi Max.
Cylinder Type AM2
 Rod wiper is standard.
 Mounting nut is not included.
 Pivot bushing NOT available.

Note:
 Remove pivot mount attachment and rotate 90° to align pivot eye to ports.

See page 63 for accessory details.

PFA Cylinder Dimensions

	1-1/16" Bore Bore Code 10	1-1/2" Bore Bore Code 15	2" Bore Bore Code 20	2-1/2" Bore Bore Code 25	3" Bore Bore Code 30
A	4.59	4.88	5.46	6.41	6.78
B	0.375	0.500	0.625	0.750	0.750
C	0.63	0.88	1.00	1.25	1.25
D	1.312	1.58	2.08	2.63	3.16
E	1.75	1.72	1.92	2.25	2.16
F	1.06	1.13	1.188	1.50	1.438
G	0.31	0.31	0.38	0.44	0.44
H	0.09	0.09	0.13	0.13	0.19
I	5/16-24 UNF	7/16-20 UNF	1/2-20 UNF	5/8-18 UNF	5/8-18 UNF
J	0.31	0.44	0.50	0.63	0.63
K	7/8-14 UNF	1 1/8-12 UNF	1 1/4-12 UNF	1 3/8-12 UNF	1 1/2-12 UNF
L	0.875	1.125	1.375	1.500	1.625
O	0.44	0.41	0.50	0.56	0.63
P	0.84	0.83	0.93	1.13	1.47
Q	0.38	0.63	0.75	0.88	0.88
R	0.875	1.125	1.375	1.500	1.625
S	0.47	0.56	0.56	0.75	0.81
T	5.06	5.44	6.02	7.16	7.59
U	5.34	5.91	6.46	7.78	8.22
V	0.250	0.375	0.375	0.500	0.500
EE	1/8 NPTF	1/4 NPTF	1/4 NPTF	3/8 NPTF	3/8 NPTF

PFA Cylinder Pricing

Bore Code	Bore Size	Base Price		Stroke Adder per Inch	Bumpers	Rod Extension per Inch	Thread Extension per Inch
		AM1	AM2				
10	1.062	\$326.32	\$331.18	\$15.17	\$2.67	\$4.38	\$8.75
15	1.5	339.91	345.61	18.20	6.85	5.34	10.67
20	2.0	363.95	371.10	21.12	9.21	6.91	13.84
25	2.5	388.10	396.80	24.15	11.82	8.75	17.47
30	3.0	413.71	426.79	27.17	11.82	13.10	26.21

PFA Series – Position Feedback Digital Displays



F-TDRO-40 Panel Meter 4 Digit 0.56" in a 1/8 DIN Case

An economical smart programmable meter with optional relay with isolated 4 to 20 mA and 0-10 VDC retransmission or control loop output capability for measurement and control applications.

Specifications

Input Specs:	IR03 Input Module
A/D Converter:	14 bit single slope
Accuracy:	±(0.05% of reading + 2 counts)
Temp. Coeff.:	100 ppm/°C (Typical)
Warm Up Time:	2 minutes
Conversion Rate:	10 conversions per second (Typical)
Display:	4 digit 0.56" Red LED display (Range – 1999 to 9999 counts)
Polarity:	Assumed positive. Displays – negative
Decimal Selection:	Front panel button selectable, X•X•X•X•
Positive Overrange:	Top segments of digital display flash
Negative Overrange:	Bottom segments of digital display flash
Relay Output:	Available combinations shown in "How to Order" page 59: 5Amp Form A is solid state; 10Amp Form C is mechanical.
Analog Output:	Isolated 16 bit user scalable mA or V
AIC (mA out) (opt)	4-20 mA @ 0 to 500 Ω max loop resistance
AIV (volts out) (opt)	0-10 DC @ 500 Ω or higher resistance
Power Supply:	AC/DC Auto sensing wide range supply
1–PS1 (std)	85-265 VAC/95-370 VDC @ 2.5W max 3.5W
2–PS2 (opt)	15-48 VAC/10-72 VDC @ 2.5W max 3.5W
Operating Temp.:	0 to 60°C
Storage Temp.:	-20 to 70°C
Relative Humidity:	95% (non-condensing)
Case Dimensions:	1/8 DIN, Bezel: 96x48mm (3.78"x1.89") Depth behind bezel: 117mm (4.61") Plus 11.8mm (0.47") for Right-angled connectors, or plus 20 mm (0.79") for straight-thru connector.
Weight:	6.5 oz., 8.5 oz. when packed

Software Features

F-TDRO-40

- Three-button programming from the front panel (UP, DOWN and PROGRAM buttons).
- Three front panel selectable ranges.
- Front panel selectable four-level brightness control of digital display, and setpoint LEDs.
- Up to four programmable setpoints.
- Relay activation can be selected to occur above (HI) or below (LO) each setpoint.
- Hysteresis setting for all four setpoints. Delay on make and delay on break for SP1 and SP2.
- Peak and Valley. View and Reset.



F-TDBRO-40 101 Segment Bargraph 4 Digit 0.31" in a 9/64 DIN Case

Smart Tricolor digital bargraph with four fully programmable setpoints and optional relay with isolated 4 to 20 mA and 0-10 VDC retransmission or control loop output for monitoring measurement and control applications.

Specifications

Input Specs:	IR03 Input Module
A/D Converter:	14 bit single slope
Accuracy:	±(0.05% of reading + 2 counts)
Temp. Coeff.:	100 ppm/°C (Typical)
Warm Up Time:	2 minutes
Conversion Rate:	10 conversions per second (Typical)
Digital Display:	4 digit 0.31" LED red (Range – 1999 to 9999 counts)
Bargraph Display:	101 segment 4" tri-color vertical
Polarity:	Assumed positive. Displays – negative
Decimal Selection:	Front panel button selectable, X•X•X•X•
Positive Overrange:	Bargraph and Top segments of digital display flash
Negative Overrange:	First segment of Bargraph and Bottom segments of digital display flash
Relay Output:	Available combinations shown in "How to Order" page 59: 5Amp Form A is solid state; 10Amp Form C is mechanical.
Analog Output:	Isolated 16 bit user scalable mA or V
AIC (mA out)(opt)	4-20 mA @ 0 to 500 Ω max loop resistance
AIV (volts out)(opt)	0-10 DC @ 500 Ω or higher resistance
Power Supply:	AC/DC Auto sensing wide range supply
1–PS1 (std)	85-265 VAC/95-370 VDC @ 2.5W max 4.2W
2–PS2 (opt)	15-48 VAC/10-72 VDC @ 2.5W max 4.2W
Operating Temp.:	0 to 60°C
Storage Temp.:	-20 to 70°C
Relative Humidity:	95% (non-condensing)
Case Dimensions:	9/64 DIN, Bezel: 36Wx144Hmm Depth behind bezel: 148mm (5.83") Plus 18mm (0.7") connectors.
Weight:	9.5 oz., 12 oz. when packed

F-TDBRO-40

- Digital display and the 101 segment bargraph can be independently scaled.
- Bargraph center zero function.
- Four programmable setpoints. (optional)
- Adjustable delay-on-make and delay-on-break time for setpoints 1 and 2.
- Relay activation can be selected to occur above (HI) or below (LO) each setpoint.
- Digital display blanking.
- Decimal point setting.
- Four-level brightness control of bargraph, digital display, and setpoint LEDs.



PFA Series – Position Feedback Digital Displays

How to Order Display

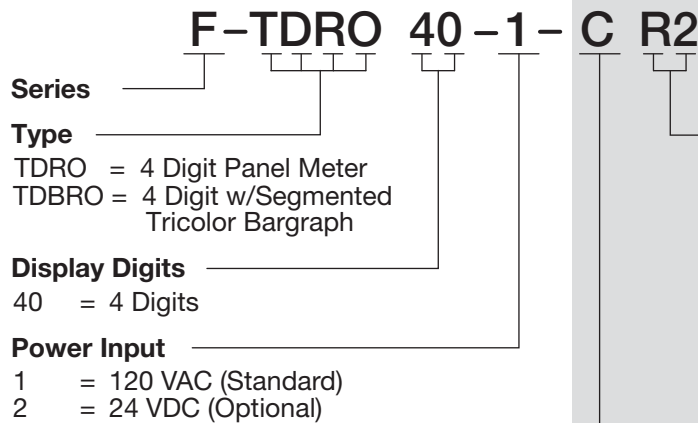

Relay Outputs

F-TDRO-40

- R0 = None
- R1 = Single 5 A (Form A)
- R2 = Dual 5 A (Form A)
- R4 = Four 5 A (Form A)

F-TDBRO-40

- R0 = None
- R11 = Single 10 A (Form C)
- R12 = Dual 10 A (Form C)
- R13 = Dual 10 A and Single 5 A
- R14 = Dual 10 A and Dual 5 A

Output

- O = No Output (Standard)
- C = 4-20 mA
- V = 0-10 VDC

PFA Digital Display Pricing



Base:

F-TDRO-40	\$219.35
F-TDBRO-40	411.90

Adders:

Power

1	16.90
2	65.85

Output

O	Standard
C	92.90
V	92.90

Relays

R0	No Charge
R1	47.30
R2	92.90
R4	167.15
R11	65.85
R12	121.55
R13	167.15
R14	206.00

Port Mounted Flow Controls



Swivel, Brass Body Flow Controls

- Full 360° Swivel • Compact Size • Pre-applied thread sealant

SPECIFICATIONS

- Male sizes:
 - #10-32, 1/8 NPT, 1/4 NPT
- Female NPT or instant tube connections:
 - 10-32, 1/8 NPT, 1/4 NPT,
 - 5/32" T, 1/4" T, 3/8" T
- Choice of controlled flow direction
 - Valve mount – Meter in
 - Cylinder mount – Meter out
- Operating pressure to 150 PSI (10 bar)
- Operating temperature: -25° to 250°F

Easy Disassembly for Maintenance



PC1-K

PC2-A

PC4-L

See dimensions and flow information on next page.

Swivel, Molded Body Flow Controls

- Full 360° Swivel • Compact Size • Pre-applied thread sealant

SPECIFICATIONS

- Male sizes:
 - #10-32, 1/8 NPT, 1/4 NPT, 3/8 NPT
- Female instant tube connections:
 - 5/32" T, 1/4" T, 3/8" T
- Operating pressure to 150 PSI (10 bar)
- Operating temperature:
 - 0 to 160°F (-18°C to 70°C)
- High flow rates (see chart at right)
- Use with air or other inert gas only
- Not recommended for use with liquids
- Meter out only

FLOW CHARACTERISTICS OF FABCO-AIR VALVES

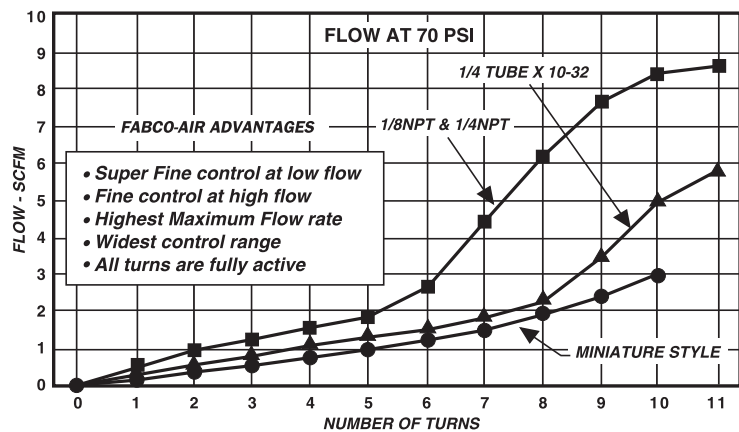

How to Order Model Numbers & Dimensions

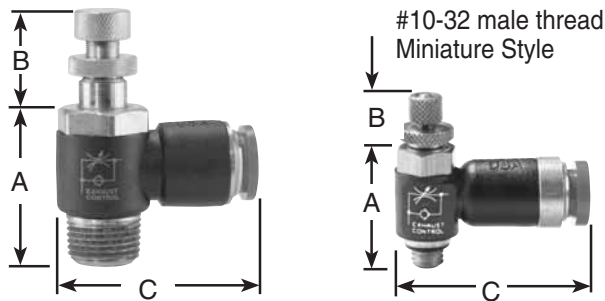

KNOB ADJUSTABLE VALVES

Model No.	Description	Price	A	B max	C	Flow (Cv)
PK-82010	5/32 tubing x 10-32	\$11.35	0.68	0.45	1.08	0.05
PK-82012	5/32 tubing x 1/8 NPT	14.40	1.05	0.75	1.25	0.13
PK-82014	5/32 tubing x 1/4 NPT	15.40	1.17	0.75	1.37	0.13
PK-82040	1/4 tubing x 10-32	13.40	0.95	0.75	1.30	0.08
PK-82042	1/4 tubing x 1/8 NPT	15.40	1.05	0.75	1.30	0.13
PK-82044	1/4 tubing x 1/4 NPT	16.35	1.17	0.75	1.40	0.13
PK-82046	1/4 tubing x 3/8 NPT	19.35	1.38	0.92	1.75	0.27
PK-82064	3/8 tubing x 1/4 NPT	18.40	1.34	0.92	1.70	0.27
PK-82066	3/8 tubing x 3/8 NPT	20.45	1.38	0.92	1.75	0.27

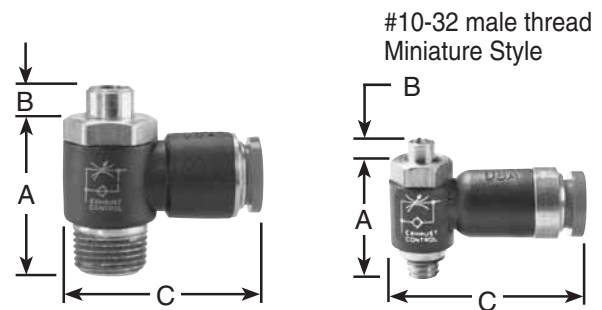

RECESSED SCREW ADJUSTABLE VALVES

Model No.	Description	Price	A	B max	C	Flow (Cv)
PR-82110	5/32 tubing x 10-32	\$10.35	0.68	0.11	1.08	0.05
PR-82112	5/32 tubing x 1/8 NPT	13.40	1.05	0.20	1.25	0.13
PR-82114	5/32 tubing x 1/4 NPT	14.40	1.17	0.20	1.37	0.13
PR-82140	1/4 tubing x 10-32	12.40	0.95	0.20	1.30	0.08
PR-82142	1/4 tubing x 1/8 NPT	14.40	1.05	0.20	1.30	0.13
PR-82144	1/4 tubing x 1/4 NPT	15.40	1.17	0.20	1.40	0.13
PR-82146	1/4 tubing x 3/8 NPT	19.35	1.38	0.28	1.75	0.27
PR-82164	3/8 tubing x 1/4 NPT	18.40	1.34	0.28	1.70	0.27
PR-82166	3/8 tubing x 3/8 NPT	20.45	1.38	0.28	1.75	0.27

F Series Port Mounted Flow Controls

Size 1 10-32 Male Thread

Knob Adjustment

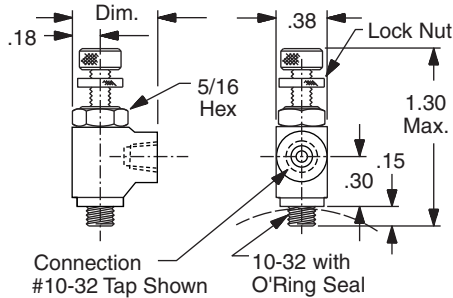

Connection #10-32 Tap Shown
 10-32 with O'Ring Seal

Screwdriver Adjustment

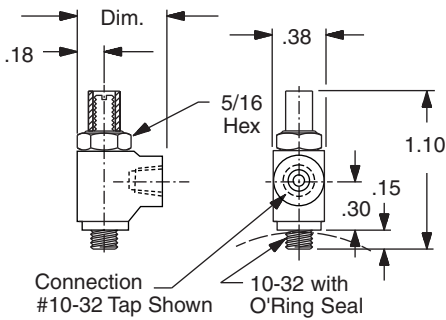

Connection #10-32 Tap Shown
 10-32 with O'Ring Seal

Flow Characteristics Typical Free Flow Maximum

Supply Pressure	Flow Rate
60 psi	1.1 SCFM
100 psi	1.8 SCFM

Size 2 1/8 NPT Male Thread

Knob Adjustment

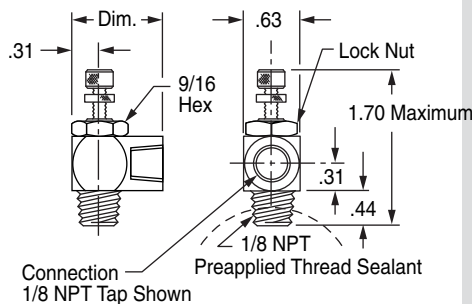

Connection 1/8 NPT Tap Shown
 1/8 NPT
 Preapplied Thread Sealant

Screwdriver Adjustment

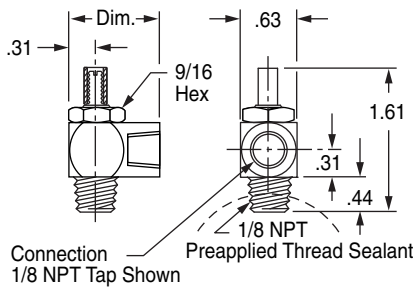

Connection 1/8 NPT Tap Shown
 1/8 NPT
 Preapplied Thread Sealant

Flow Characteristics Typical Free Flow Maximum

Supply Pressure	Flow Rate
60 psi	10.4 SCFM
100 psi	16.0 SCFM

Size 4 1/4 NPT Male Thread

Knob Adjustment

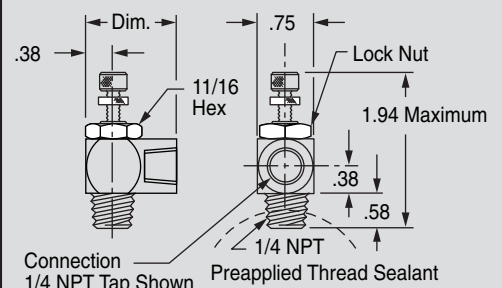

Connection 1/4 NPT Tap Shown
 1/4 NPT
 Preapplied Thread Sealant

Screwdriver Adjustment

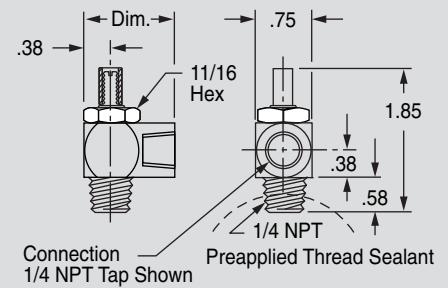

Connection 1/4 NPT Tap Shown
 1/4 NPT
 Preapplied Thread Sealant

Flow Characteristics Typical Free Flow Maximum

Supply Pressure	Flow Rate
60 psi	15.9 SCFM
100 psi	24.8 SCFM

Male Thread	Adjustment	Connection	Model Number / Price				Dim.
			Valve Mount Meter In	Price	Cylinder Mount Meter Out	Price	
Size #1 #10-32	Knob	10-32 Tap	PV1-A	\$13.05	PC1-A	\$11.90	.63
		5/32" Tube	PV1-C	14.75	PC1-C	13.60	1.16
	Screwdriver	10-32 Tap	PV1-K	12.00	PC1-K	10.80	.63
		5/32" Tube	PV1-M	13.00	PC1-M	11.80	1.16
Size #2 1/8 NPT	Knob	1/8 NPT Tap	PV2-A	15.10	PC2-A	13.95	1.00
		5/32" Tube	PV2-C	17.30	PC2-C	16.10	1.65
		1/4" Tube	PV2-D	17.30	PC2-D	16.10	1.63
	Screwdriver	1/8 NPT Tap	PV2-K	13.90	PC2-K	12.75	1.00
		5/32" Tube	PV2-M	15.20	PC2-M	14.05	1.65
		1/4" Tube	PV2-N	15.20	PC2-N	14.05	1.63
Size #4 1/4 NPT	Knob	1/4 NPT Tap	PV4-A	19.35	PC4-A	18.20	1.25
		1/4" Tube	PV4-B	21.75	PC4-B	20.60	1.75
		3/8" Tube	PV4-C	21.75	PC4-C	20.60	2.00
	Screwdriver	1/4 NPT Tap	PV4-K	17.50	PC4-K	16.30	1.25
		1/4" Tube	PV4-L	19.15	PC4-L	18.00	1.75
		3/8" Tube	PV4-M	19.15	PC4-M	18.00	2.00

Cylinder Accessories

Magnetic Position Sensors



Temperature range: -4° to +176°F (-20° to +80°C)

Magnetically operated reed switches and electronic sensors can be mounted anywhere along the length and circumference of the cylinder. A magnetic piston is required and is standard on Magnetic Interchange cylinders. Specify Magnetic Piston Option “-03” for other F-Series models or “-12” for 3-position models

Dovetail Style Sensors		Prewired 9 ft. Leadwire	Quick Disconnect*
Sensor Type	Electrical Characteristics	Part No.	Price
Reed (No LED)	0-120 VDC/VAC, 0.5 Amp Max current, 5 Watt Max, 0 Voltage Drop	949-000-001	\$18.05
Reed (LED)	5-120 VDC/VAC, 0.03 Amp Max current, 4 Watt Max, 2.0 Voltage Drop	949-000-002	18.85
Electronic (LED)	Sourcing PNP 6-24 VDC, 0.20 Amp Max current, 0.5 Voltage Drop	949-000-031	23.80
Electronic (LED)	Sinking NPN 6-24 VDC, 0.20 Amp Max current, 0.5 Voltage Drop	949-000-032	23.80

*Note: Quick disconnect styles are supplied with 6 inch pigtail with male connector. Order female cordsets separately from chart below.

- Encased in a plastic housing, dovetail style sensors are corrosion resistant. 60° wire outlet allows close mounting.
- Two methods of mounting are available: one is fastened to the cylinder barrel with a **band clamp** (not included with sensor – must be ordered separately); the second is an adhesive-backed **mounting rail** with twin dovetail slots.

F-Series cylinder with rail mounted dovetail sensors shown on one of Fabco-Air's linear slide products.

Mounting Options

Band Clamp Adapter for Dovetail Sensors
(Must be ordered separately)

Part No. 900-300-000
Price: \$8.15

Dovetail Rail as shown above (must be ordered separately). Order by **Part No. “ER – length”** where the length is known, or by **“ER – cylinder model no.”**
Example: “ER-F-1062D02-04A-03”
Model no. of cylinder allows factory to determine the length needed. (Estimated length for pricing purposes is “stroke + 1”)
Price: \$2.95 + \$1.05 per inch length
Supplied with double sided tape affixed.
Application recommendations:
a) Clean cylinder body O.D. with acetone. Remove all oil from surface.

- b) Do not apply the rail over the crimped body edge.
 - c) Double check positioning of the rail.
 - d) High performance double sided tape offers convenient “peel and stick” but is very aggressive, giving you only one chance. Be careful !
 - e) Remove protective film from tape and place rail in desired position.
 - f) Firmly press the rail to cylinder body.
- Alternatively, the extruded aluminum rail can be fastened using Loctite® U-05FL urethane adhesive or similar. Follow product manufacturer's recommendations for application.

Clamp on Style Sensors		Prewired 9 ft. Leadwire	Quick Disconnect*
Sensor Type	Electrical Characteristics	Part No.	Price
Reed (LED)	5-120 VAC/VDC, 0.5 AMP Max, 10 Watt Max, SPST N.O. 3.5 voltage drop	9-2A197-1003	\$29.90
Electronic (LED)	Sourcing, PNP, 6-24 VDC, 0.5 Amp Max, 1.0 voltage drop	9-2A197-103132.05
Electronic (LED)	Sinking, NPN, 6-24 VDC, 0.5 Amp Max, 1.0 voltage drop	9-2A197-103232.05

Band Clamp for Clamp On Sensors
(must be ordered separately)

Part No. 800-A00-000 **Price: \$7.70**



Prewired style sensors are supplied with a 9 foot leadwire.

*Quick disconnect style sensors are supplied with male connector as shown in this photo. Order female cordsets separately from the chart below.

Female Cordsets for Quick Disconnect Sensors		
Cordset Length	Part No.	Price
1 Meter	CFC-1M	\$14.35
2 Meters	CFC-2M	16.05
5 Meters	CFC-5M	20.30

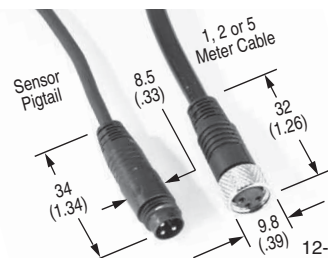

Nose Mounting Brackets

A	B	C	D	E	F	G	H	I	J	K	Part #	Price
1.00	.38	.063	.25	.38	.14	.13	.438	.251	.31	.75	F-M117001	\$1.79
1.00	.38	.063	.25	.38	.14	.13	.438	.376	.31	.75	F-M117002	1.79
1.38	.50	.094	.38	.69	.20	.13	.563	.438	.38	.83	F-M117003	1.92
1.38	.50	.063	.31	.63	.20	.13	.563	.376	.31	.88	F-M117004	1.92
1.88	.75	.125	.56	1.00	.26	.25	.813	.626	.56	1.38	F-M117005	2.55
1.63	.63	.094	.44	.75	.20	.19	.688	.501	.41	1.09	F-M117006	2.12
2.50	.94	.125	.75	1.50	.28	.63	1.000	.751	.75	1.75	F-M117007	3.57
3.00	1.13	.188	.88	1.50	.34	.75	1.250	1.032	.91	2.13	F-M117008	5.80
3.13	1.13	.250	1.00	1.63	.34	.63	1.500	1.376	1.00	2.50	F-M117009	7.65
3.75	1.44	.250	1.00	1.63	.34	.75	1.750	1.501	1.25	3.00	F-M117010	20.46
4.38	1.75	.250	1.00	1.63	.34	.89	1.890	1.626	1.25	3.14	F-M117011	13.31
2.75	1.06	.188	.81	1.44	.34	.38	1.250	1.126	.91	2.19	F-M117012	18.60
2.13	.78	.157	.66	1.16	.28	.32	1.000	.876	.75	1.75	F-M117013	8.74

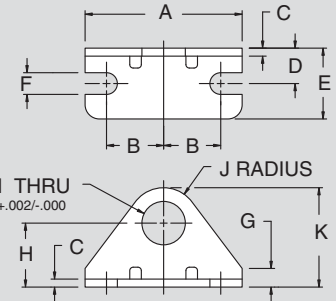

Pivot Mounting Brackets

A	B	C	D	E	F	G	H	J	L	M	Part #	Price
.77	.50	.75	.157	.20	.56	.13	.50	.063	.28	.20	F-M029002	\$3.05
1.19	.81	1.13	.250	.31	.88	.19	.75	.125	.44	.26	F-M029003	3.05
1.75	1.00	1.50	.375	.38	1.38	.25	1.00	.125	.63	.26	F-M029004	5.24
1.75	1.13	1.50	.500	.38	1.38	.25	1.00	.250	.69	.26	F-M029006	13.37

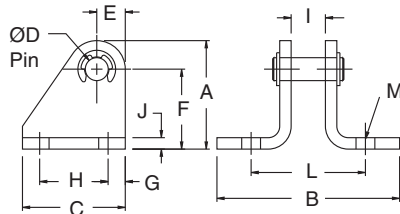
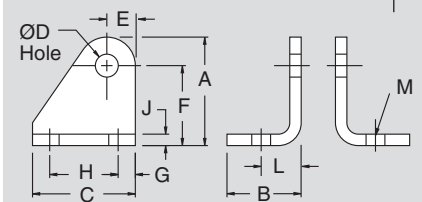

A	B	C	D	E	F	G	H	I	J	L	M	Part #	Price
.77	1.34	.75	.157	.20	.56	.13	.50	.34	.063	.90	.20	F-M129002	\$5.85
1.19	2.00	1.13	.250	.31	.88	.19	.75	.38	.125	1.25	.26	F-M129003	5.55
1.75	2.88	1.50	.375	.38	1.38	.25	1.00	.63	.250	2.00	.26	F-M129005	10.70
1.19	2.12	1.13	.250	.31	.88	.19	.75	.50	.125	1.38	.26	F-M229003	6.64
1.75	3.00	1.50	.375	.38	1.38	.25	1.00	.75	.250	2.13	.26	F-M229005	10.70
2.25	3.88	1.75	.500	.50	1.75	.25	1.25	.88	.250	2.63	.26	F-M229006	14.67

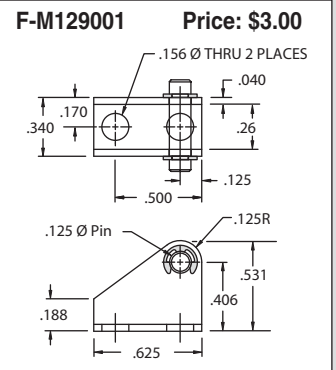

Rod Clevises

A	B	C	D	E	F	G	H	I	Part #	Price
.31	.56	.53	.125	.13	.31	.38	.44	#5-40	F-M127001	\$3.00
.38	.94	.56	.188	.19	.38	.56	.75	#10-32	F-M127002	3.05
.50	1.19	.68	.250	.25	.50	.68	.94	1/4-28	F-M127003	3.51
.50	1.19	.68	.250	.25	.50	.68	.94	5/16-24	F-M127004	3.51
.75	1.69	1.03	.375	.38	.75	.94	1.31	7/16-20	F-M127005	5.80
.75	1.69	1.03	.375	.38	.75	.94	1.31	1/2-20	F-M127006	5.80
1.00	2.75	1.28	.500	.50	1.00	1.50	2.25	5/8-18	F-M127007	15.50

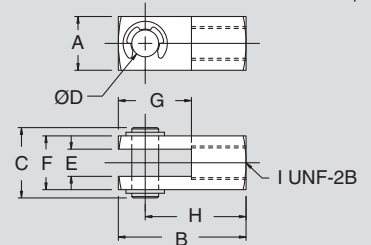

Mounting Nuts & Rod Thread Nuts

Part #	A	B	C	Price
F-M18-004	.500	5/16-24	.19	\$1.61
F-M190001	.438	1/4-28	.16	.26
F-M190002	.562	3/8-24	.22	.26
F-M190003	.687	7/16-20	.25	.26
F-M190004	.750	1/2-20	.31	.39
F-M190005	.938	5/8-18	.38	.39
F-M190006	1.125	3/4-16	.42	.51
F-M190007	1.312	7/8-14	.48	1.58

Part #	A	B	C	Price
F-M190008	1.500	1-14	.55	\$2.36
F-M190009	1.875	1 1/4-12	.50	3.64
F-M190012	2.062	1 3/8-12	.50	5.74
F-M190013	2.250	1 1/2-12	.50	5.74
F-M190015	1.688	1 1/8-12	.61	4.45
F-M19S005	.938	5/8-18	.38	4.55
F-M19S006	1.500	1-14	.55	8.45

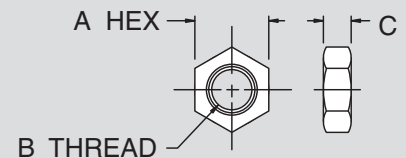



FABCO-AIR, Inc. ■ 3716 N.E. 49th Avenue ■ Gainesville, FL 32609-1699
 ■ Telephone (352) 373-3578 ■ Fax (352) 375-8024 ■ E-Mail service@fabco-air.com
 ■ Web Site <http://www.fabco-air.com>

Fabco-Air Product Catalog Library



*Cylinders, Valves and Accessories
 Catalog #CV9*

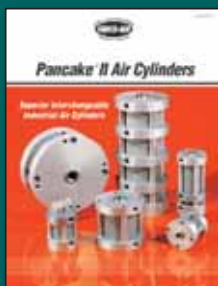

*Pancake® II Air Cylinders
 Catalog Pan2-2*



*Square Pancake® II Air Cylinders
 Catalog # SqPan2*



*ISO 6431 Cylinders
 Catalog # FAQR-09*



Twin Rod, Non-Rotating Air Cylinders - Catalog # FDF-09 and Catalog # FDXS-09



*Multi-Power® Air Presses
 Catalog # FP16*



*Linear Slides - 6 Families
 Catalog # LS-03*

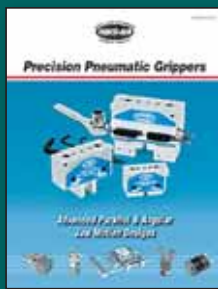

Pneumatic Grippers, Parallel Jaw and Angular Motion - Catalog # GR-8



*Pneumatic Angular Grippers
 Catalog # FKA-09*



*ISO 6432 Cylinders
 Catalog # FAE-09*



NFPA Interchangeable Air Cylinders - Catalog # NF-6

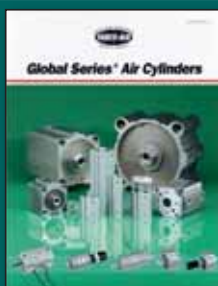

Global Series™ Metric Air Cylinders - Catalog # GC-15



*Swing Clamps
 Bulletin # SC-DB04*



*Manifold Solenoid Valves
 Catalog # FVS-Y-09*



*Air Pilot & Solenoid Valves
 Catalog # FVA-E-09*



*Modular Air Preparation System - FRLs
 Catalog # FRL-06*



*Stopper Cylinders
 Catalog # ST-SC*

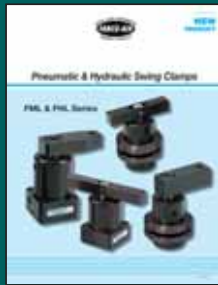

*Swing Clamps, Pneumatic & Hydraulic
 Catalog # FML-H*

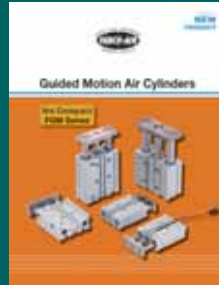

*Guided Motion Air Cylinders
 Catalog # FGM-10*



*Air Slide Tables
 Catalog # FGXS-10*