

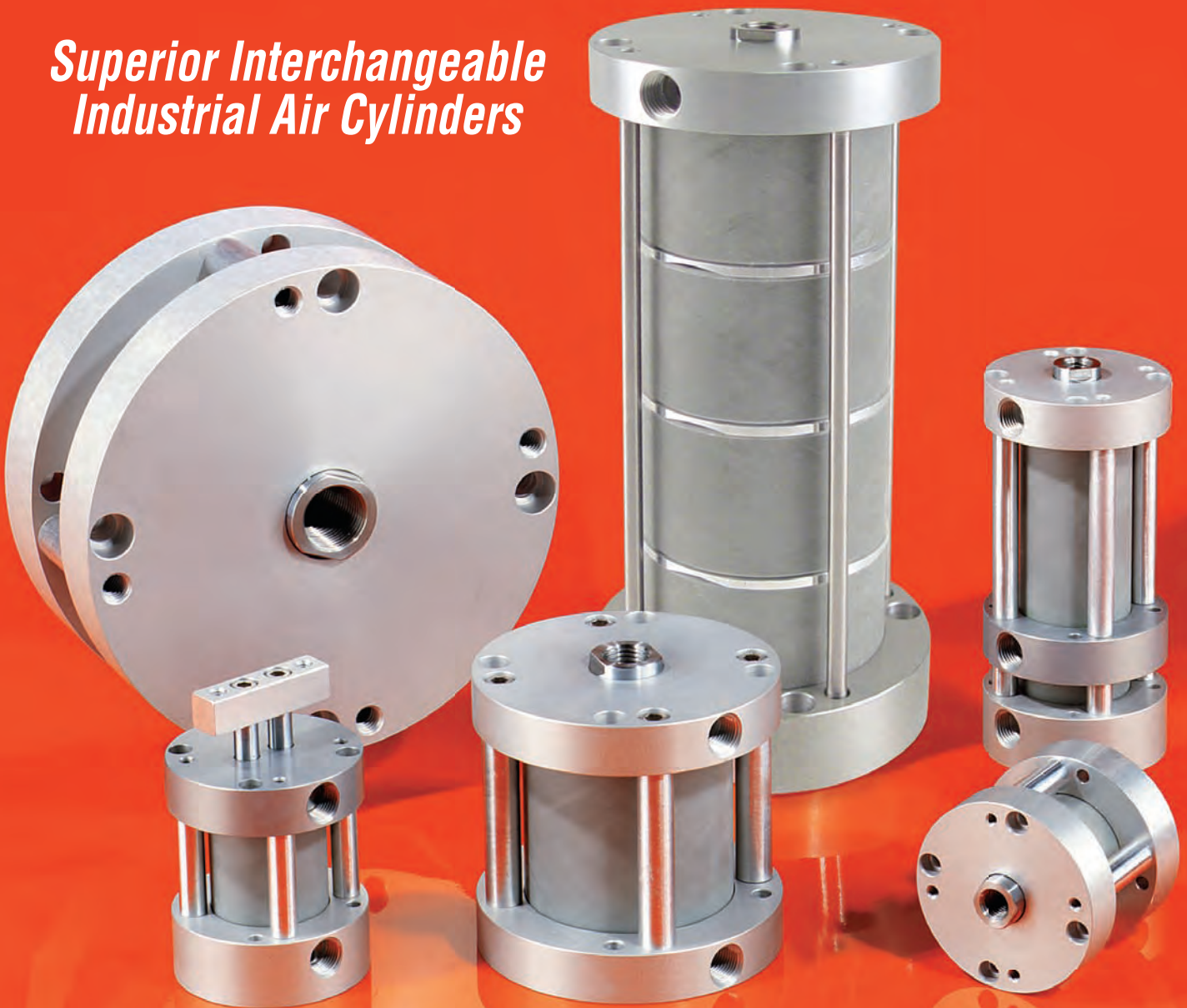

Pancake[®] II Air Cylinders

*Superior Interchangeable
Industrial Air Cylinders*



Product Index



Standard Series PSD, PSR, PSX, PWD, PTD

How it works	3
How to Order	5
Dimensions	6 - 9
Options	8, 9
Weights	7
Repair kits	9

Nonrotating , Twin Rod Series PND

How it works	10
How to Order	11
Dimensions	12, 13
Options	12, 13
Weights	13
Repair kits	13

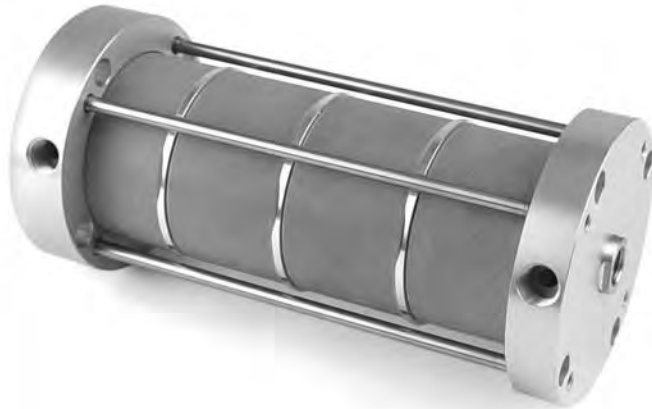

Multi-Power® Series PA and PB

How it works	14
How to Order	15
Dimensions	16, 17
Options	17
Weights	17
Repair kits	17

3-Position Series P3D

How it works	18
How to Order	19
Dimensions	20, 21
Options	20, 21
Weights	21
Repair kits	21

Magnetic Position Sensing

Sensors	23
Quick disconnect cordsets	23

Accessories

All Series	22
----------------------	----

The Pancake® II Direct Interchange Air Cylinders

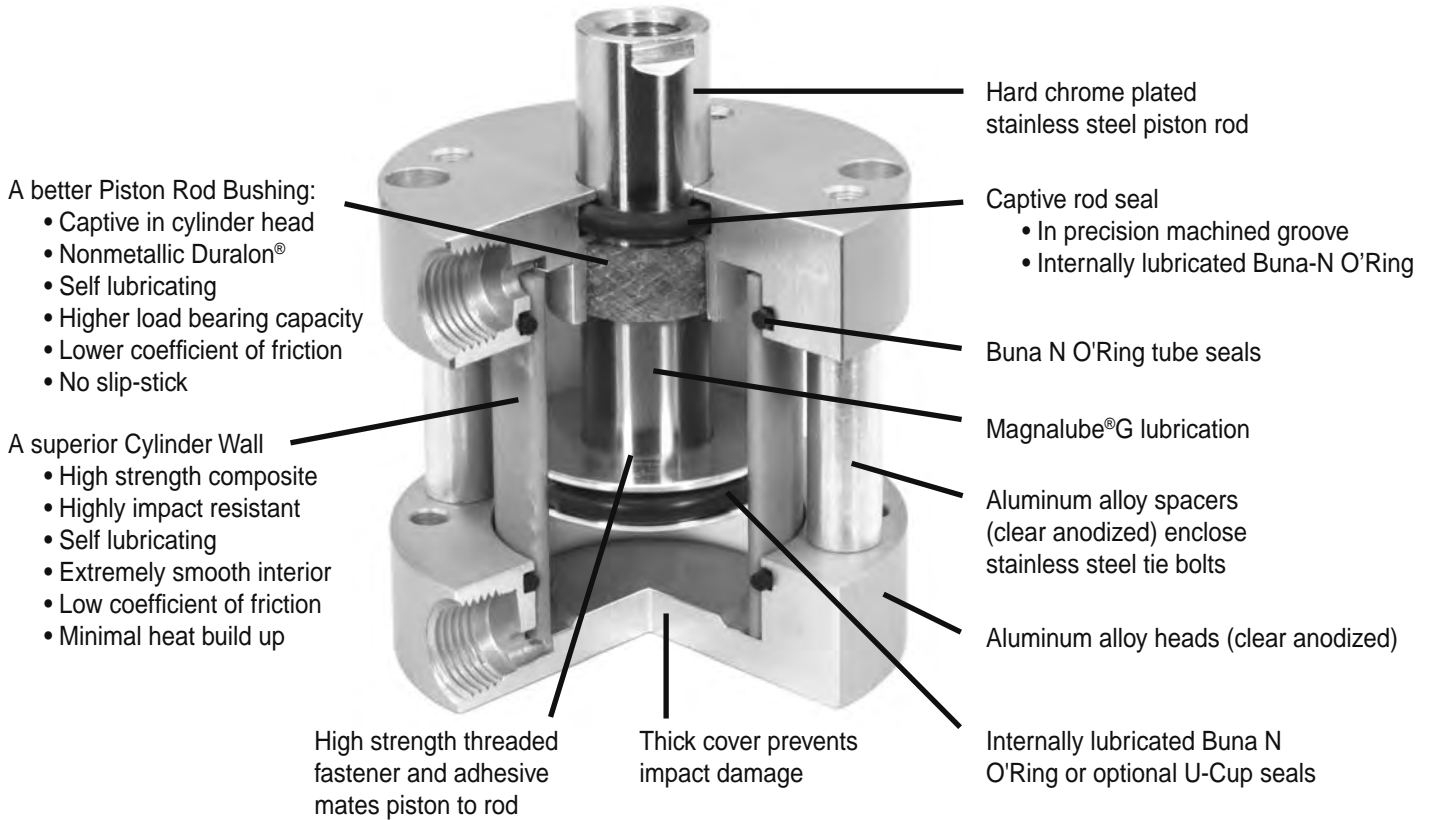

Superior Interchangeable Industrial Air Cylinders

Innovation – For over 40 years our famous Pancakes® have dominated as the world's first compact air cylinder line. Today, backed by decades of engineering and manufacturing innovation, our new **Pancake® II** composite body air cylinders continue in the Pancake® tradition with a wide selection of models and options.

Packed with value – Stainless steel tie bolts and aluminum spacers lock precision machined heads tightly around a unique, high strength, composite cylinder barrel. The barrel's extremely smooth, self-lubricating interior surface insures highly reliable performance and extended seal life. Its high impact resistance reduces chances of cylinder failure due to dings or dents. Zero slip-stick avoids problems that metal cylinders encounter when they sit in a static condition for extended periods of time. Combined with hard chrome plated stainless steel piston rods and a unique, nonmetallic rod bearing, the new Fabco-Air cylinder assembly assures optimal operation and longer product life.

Exceptional Piston Rod Bearing – The better the bearing, the more cycle life you can expect from your air cylinders. **Pancake® II** cylinders incorporate a truly superior rod

Duralon® Rod Bearings Excel

Load Capacity (psi)		Friction Properties		Slip-stick
			Coefficient	
Machine Design 1972/73				
Bearing Reference Issue				
Porous Bronze.....	4,500	Steel-on-steel.....	.50	Yes
Porous iron.....	8,000	Bronze-on-steel.....	.35	Yes
Phenolics.....	6,000	Sintered Bronze-on-steel		
Nylon®.....	1,000	with mineral oil.....	.13	No
TFE.....	500	Bronze-on-steel		
Reinforced Telfon®.....	2,500	with mineral oil.....	.16	No
*TFE fabric.....	60,000	Copper lead alloy-on-steel	.22	Yes
Polycarbonate.....	1,000	Acetal-on-steel.....	.20	No
Acetal.....	1,000	Nylon-on-steel.....	.32	Yes
Carbon-graphite.....	600	Duralon-on-steel.....	.05 - .16	No

* Shows Duralon bearing classification. Not to be used for design purposes.

Printed with permission by Rexnord Corp.

bearing material - Duralon® with the same field-proven performance you have come to expect from the six other Fabco-Air cylinder families.

Duralon® is a composite of a Teflon®/Dacron® fabric liner bonded to a supporting filament-wound, high strength, fiberglass and epoxy resin shell. Resistant to corrosion, moisture and temperature to 325°F, the bearing is reliable in any environment. It has an extremely high load bearing capacity, very low friction, and will not gall or score the piston rod (see physical properties in the table above).

How to Order

<p>Series P - Pancake® II</p>	<p>Action D - double acting R - single acting, spring retract (Model S only) X - single acting, spring extend (Model S only)</p>	<p>Bore 1 - 1/2" 2 - 3/4" 3 - 1-1/16" 4 - 1-1/2" 5 - 2" 6 - 2-1/2" 7 - 3" 8 - 4"</p>	<p>Stroke 0.125 - 1/8" 0.250 - 1/4" 0.375 - 3/8" 0.500 - 1/2" etc., thru 4.000 - 4" (see pages 6 & 7 for standard strokes)</p>	<p>Note: Special strokes are available on request. Contact Engineering or your local Fabco-Air Distributor.</p>
<p>Model S - single rod W - double rod T - double rod, hole thru</p>				

Model Number **Series** **Model** **Action** **Bore** - **Mounting** **Stroke** - **Options**

Mounting

Leave blank for standard counterbored mounting holes (see page 6) in the basic model. For other mounting specify only one option code.

- CB - Screw head clearance holes, both ends¹
- CF - Screw head clearance holes, front¹
- CR - Screw head clearance holes, rear¹
- F - Nose mount (all except double rod models)²
- HB - Threaded mounting holes, both ends
- HF - Threaded mounting holes, front
- HR - Threaded mounting holes, rear
- PM - Pivot mount, pin 90° from port
- SM - Pivot mount, pin in-line with port
- TB - Trunnion mount, both ends³
- TF - Trunnion mount, front³
- TR - Trunnion mount, rear³

- ¹ "Screw head clearance" to allow bolt head to pass through; No counter bores (see page 8)
² Includes heavy duty rear head and rod wiper
³ Not available in 1/2" bore.

How to Order

1. Specify **P**, Model, Action, and Bore
2. Specify optional Mounting (if required), then Stroke
3. Specify the Options in alphabetical order

Ordering example #1: **PTD4-HF2.500-TCFV**

Pancake® II with double rod hole thru, double acting, 1-1/2" bore, front threaded mounting holes, 2-1/2" stroke, coarse female rod thread, and Viton seals.

Ordering example #2: **PSD3-1.000**

Pancake® II with single rod, double acting, 1-1/16" bore, standard counterbored mounting holes and 1" stroke.

Options *Enter in alphabetical order*

- B - Bumpers, both ends¹
- BF - Bumper, front only¹
- BR - Bumper, rear only¹
- E - Magnet on piston for position sensing (see length adders page 9) 3/8" stroke minimum²
- H - Heavy duty rear head (see length adder page 9)
- J - Failsafe operation (single acting, spring retract models)³
- L - Low friction seals (see length adders page 9)
- M, M1, M3, M4 - Magnet on piston and adhesive mounted dovetail extrusion to hold 1/4" dovetail sensors. (see sensors page 23; length adders page 9) 3/8" stroke min.²
- P2, P3, P4 - Front port position other than standard⁴
- Q - Low temperature operation (-40°F to +200°F)
- TCF - Coarse female rod thread, dimension E (page 7)
- TCM - Male rod end with coarse thread (page 8)
- TFM - Male rod end with fine thread (page 8)
- TN - Non-threaded rod
- T1, T3, T4 - Additional adhesive mounted dovetail extrusions located in position 1, 3, or 4
- V - Viton seals for media compatibility (-15°F to +221°F)
- W - Rod wiper, Buna N only (page 8)
- X - **EXTRA** rod extension
Example: X0.5 = 1/2" **EXTRA** Rod Extension
X1 = 1" **EXTRA** Rod Extension

- ¹ Stroke is reduced by .03 per end; .06 for option B; Spring retracted, BR only; Spring extended, BF only.
² Not available with Viton seals or low temperature seals.
³ Not available in 1/2" bore.
⁴ P2 and P4 not available in 1/2" bore.

Pancake® II Cylinders

Model PSD Double Acting, Single Rod

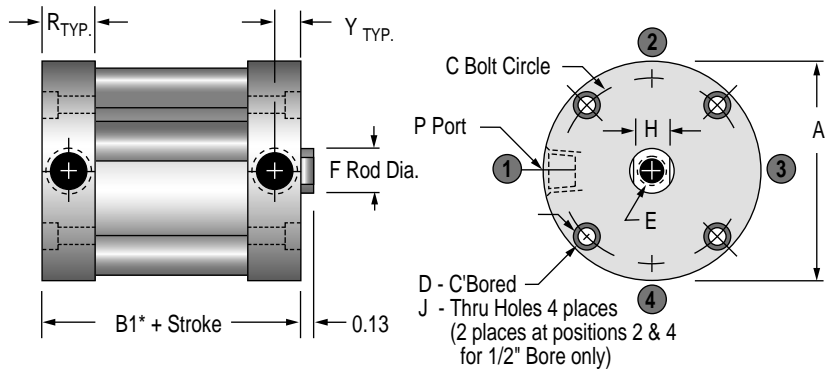

***Note: Some options effect cylinder length**

Standard Strokes – All Models: • 1/8 • 1/4 • 3/8 • 1/2 • 5/8 • 3/4 • 7/8 • 1 • 1-1/4 • 1-1/2 • 1-3/4 • 2 • 2-1/2 • 3 • 3-1/2 • 4
Special strokes available on request. Contact Engineering or your local Fabco-Air Distributor

Model PWD Double Acting, Double Rod Model PTD Double Acting, Hole Thru Double Rod

Hole Thru Diameter (PTD)

Bore	Female Rod Thread	Male Rod Thread
1/2 (1)	0.14	N/A
3/4 (2)	0.14	0.09
1-1/16 (3)	0.22	0.16
1-1/2 (4)	0.28	0.19
2 (5)	0.38	0.25
2-1/2 (6)	0.38	0.25
3 (7)	0.44	0.31
4 (8)	0.50	0.38

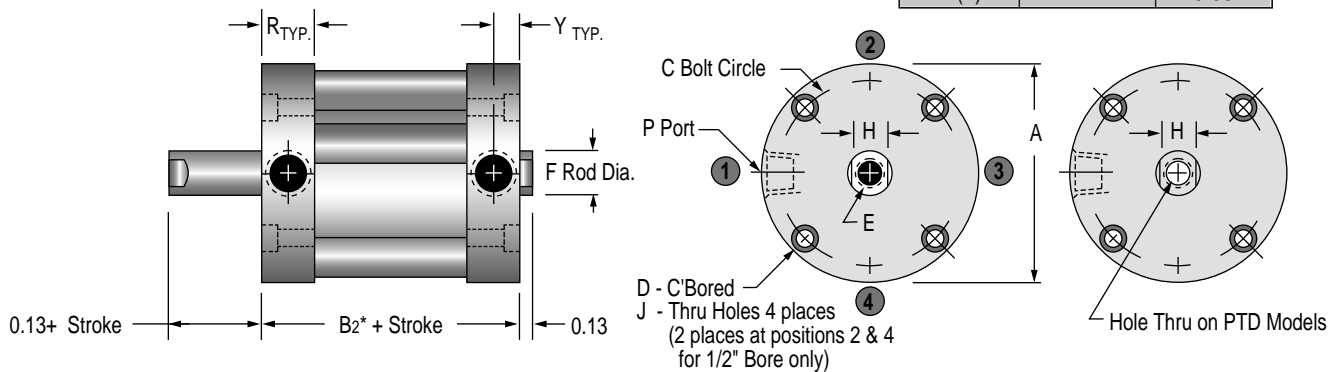

***Note: Some options effect cylinder length**

Dimensions (inches)

Bore	A	B1*	B2*	B3* for Stroke Range				B4* for Stroke Range				C	D C'Bore
				0-1	1.001-2	2.001-3	3.001-4	0-1	1.001-2	2.001-3	3.001-4		
1/2 (1)	1.12	0.56	0.69	0.81	1.38	1.96	2.52	1.06	1.62	2.14	3.21	0.88	0.20 x 0.13 dp
3/4 (2)	1.49	0.56	0.69	0.81	1.38	1.94	2.50	1.06	1.62	2.19	2.75	1.22	0.24 x 0.15 dp
1-1/16 (3)	1.99	0.88	0.94	0.88	1.50	2.13	2.75	1.38	2.00	2.63	3.25	1.69	0.24 x 0.15 dp
1-1/2 (4)	2.62	0.88	1.00	0.88	1.50	2.13	2.75	1.38	2.00	2.63	3.25	2.19	0.34 x 0.22 dp
2 (5)	3.12	0.94	1.06	0.94	1.56	2.19	2.81	1.44	2.06	2.69	NA	2.69	0.34 x 0.22 dp
2-1/2 (6)	3.75	1.19	1.31	1.19	2.06	2.94	3.81	1.94	2.81	2.81	NA	3.25	0.40 x 0.27 dp
3 (7)	4.25	1.25	1.38	1.25	2.12	3.00	3.88	2.00	2.88	2.88	NA	3.78	0.40 x 0.27 dp
4 (8)	5.50	1.56	1.69	1.56	2.44	3.31	4.19	2.31	3.19	3.19	NA	4.94	0.49 x 0.33 dp

Standard Series PSD, PSR, PSX, PWD, PTD Basic Dimensions

Model PSR Single Acting, Spring Retract

See table on page 4
for spring forces

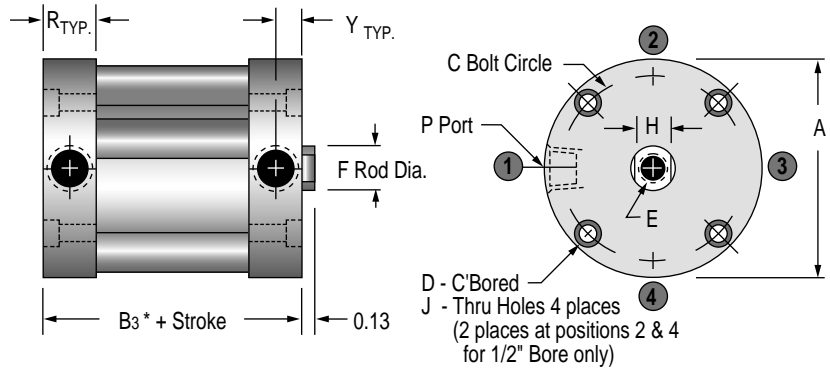

*Note: Some options effect cylinder length

Standard Strokes – All Models: • 1/8 • 1/4 • 3/8 • 1/2 • 5/8 • 3/4 • 7/8 • 1 • 1-1/4 • 1-1/2 • 1-3/4 • 2 • 2-1/2 • 3 • 3-1/2 • 4
Special strokes available on request. Contact Engineering or your local Fabco-Air Distributor

Model PSX Reverse Acting, Spring Extend

See table on page 4
for spring forces

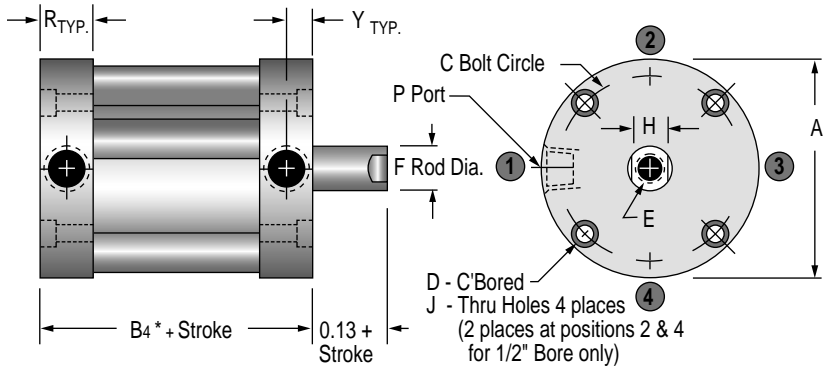

*Note: Some options effect cylinder length

Approximate Cylinder Weights (ounces) PSD, PSR, PWD, PTD, PSX

Bore	PSD, PSR		PWD, PTD		PSX		Nose Mount Option	
	Base	Adder per 1/8 of Stroke	Base	Adder per 1/8 of Stroke Model PWD	Adder per 1/8 of Stroke for Model PTD	Base	Adder per 1/8 of Stroke	Adder to Base Weight
1/2 (1)	1.15	.06	1.26	.14	.08	1.25	.06	0.1
3/4 (2)	1.82	.08	2.03	.18	.13	1.92	.08	0.2
1-1/16 (3)	4.70	.24	5.61	.37	.25	5.09	.24	1.1
1-1/2 (4)	9.22	.32	10.84	.55	.42	10.08	.32	1.8
2 (5)	12.48	.40	14.71	.64	.50	13.44	.40	2.7
2-1/2 (6)	21.50	.48	27.10	.74	.59	24.00	.48	3.1
3 (7)	27.74	.64	36.78	1.01	.76	31.20	.64	3.5
4 (8)	53.47	.80	69.50	1.20	.92	59.33	.80	5.9

Dimensions (inches)

Bore	E Standard	E Coarse	E Depth for Stroke Range		F	H	J Hole	P Port	R	Y
			1/8 – 1/2	5/8 +						
1/2 (1)	#8-32 UNC	N/A	0.30-0.46	0.46	0.25	0.22	0.13	#10-32 UNF	0.34	0.14
3/4 (2)	#10-32 UNF	#10-24 UNC	0.30-0.46	0.46	0.31	0.25	0.15	#10-32 UNF	0.34	0.14
1-1/16 (3)	5/16-24 UNF	5/16-18 UNC	0.37-0.63	0.70	0.50	0.44	0.15	1/8 NPT	0.50	0.25
1-1/2 (4)	3/8-24 UNF	3/8-16 UNC	0.37-0.70	0.70	0.63	0.50	0.20	1/8 NPT	0.50	0.25
2 (5)	1/2-20 UNF	1/2-13 UNC	0.30-0.63	0.70	0.75	0.63	0.20	1/8 NPT	0.53	0.25
2-1/2 (6)	1/2-20 UNF	1/2-13 UNC	0.42-0.70	0.70	0.75	0.63	0.26	1/4 NPT	0.66	0.33
3 (7)	5/8-18 UNF	5/8-11 UNC	0.45-0.73	0.73	0.88	0.75	0.26	1/4 NPT	0.69	0.33
4 (8)	3/4-16 UNF	3/4-10 UNC	0.40-0.70	0.80	1.00	0.88	0.33	3/8 NPT	0.84	0.42

Pancake® II Cylinders

Model Options

Male Rod Ends
 (Option TCM or TFM)

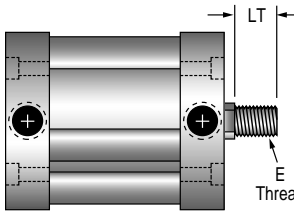

Thread Sizes			
Bore	E Thread		LT
	TCM (Coarse)	TFM (Fine)	
1/2 (1)	N/A	#8-32 UNC	0.38
3/4 (2)	#10-24 UNC	#10-32 UNF	0.38
1-1/16 (3)	5/16-18 UNC	5/16-24 UNF	0.50
1-1/2 (4)	3/8-16 UNC	3/8-24 UNF	0.50
2 (5)	1/2-13 UNC	1/2-20 UNF	0.63
2-1/2 (6)	1/2-13 UNC	1/2-20 UNF	0.63
3 (7)	5/8-11 UNC	5/8-18 UNF	0.75
4 (8)	3/4-10 UNC	3/4-16 UNF	0.75

Rod Wiper
 (Option W)
 Buna-N only

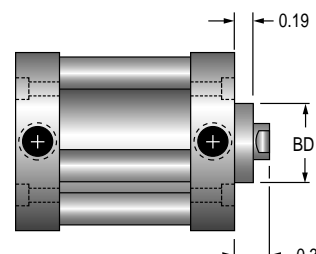

Boss Dia.	
Bore	BD
1/2 (1)	0.56
3/4 (2)	0.69
1-1/16 (3)	0.88
1-1/2 (4)	1.00
2 (5)	1.13
2-1/2 (6)	1.13
3 (7)	1.25
4 (8)	1.38

Mounting Options

Pivot Mount

Complete with bronze pivot bushing.
 Not available as an accessory. (SM shown)

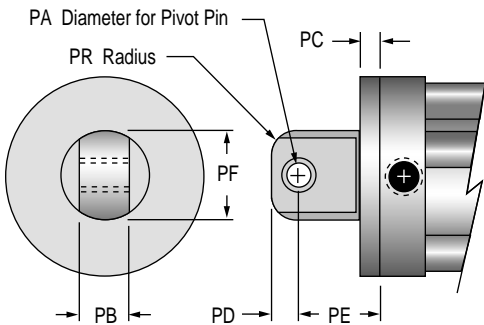

Screw Head Clearance Holes

Available either or both ends.
 (CR shown)

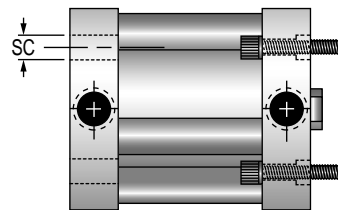

Trunnion Mount

Available rear, front or both.
 Not available on 1/2" bore.
 (TF shown solid)

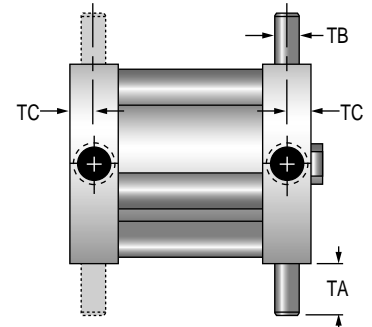

Dimensions (inches)

Bore	PA	PB	PC	PD	PE	PF	PR	SC	TA	TB	TC
1/2 (1)	0.19	0.38	0.19	0.25	0.75	0.63	0.19	0.17	NA	NA	NA
3/4 (2)	0.19	0.38	0.19	0.25	0.75	0.75	0.19	0.23	0.31	0.125	0.17
1-1/16 (3)	0.19	0.38	0.25	0.25	0.81	0.75	0.19	0.25	0.50	0.250	0.25
1-1/2 (4)	0.38	0.75	0.25	0.44	1.19	1.38	0.38	0.34	0.50	0.250	0.25
2 (5)	0.38	0.75	0.31	0.44	1.25	1.38	0.38	0.34	0.50	0.250	0.25
2-1/2 (6)	0.38	0.75	0.38	0.44	1.31	1.38	0.38	0.41	0.63	0.312	0.33
3 (7)	0.63	1.00	0.38	0.56	1.69	1.88	0.38	0.41	0.63	0.312	0.33
4 (8)	0.63	1.00	0.44	0.56	1.75	1.88	0.38	0.50	0.75	0.375	0.42

Series PSD, PSR, PSX, PWD, PTD Option Dimensions

Seal Kits – Series PSD, PSR, PSX, PWD, PTD

Options	Kit Numbers by Bore Size							
	1/2"	3/4"	1-1/16"	1-1/2"	2"	2-1/2"	3"	4"
Standard	PS-1-SK	PS-2-SK	PS-3-SK	PS-4-SK	PS-5-SK	PS-6-SK	PS-7-SK	PS-8-SK
Viton (V)	PS-1-SKV	PS-2-SKV	PS-3-SKV	PS-4-SKV	PS-5-SKV	PS-6-SKV	PS-7-SKV	PS-8-SKV
Low Temperature (Q)	PS-1-SKQ	PS-2-SKQ	PS-3-SKQ	PS-4-SKQ	PS-5-SKQ	PS-6-SKQ	PS-7-SKQ	PS-8-SKQ
Low Friction (L)	PS-1-SKL	PS-2-SKL	PS-3-SKL	PS-4-SKL	PS-5-SKL	PS-6-SKL	PS-7-SKL	PS-8-SKL
Low Friction-Viton (L, V)	PS-1-SKLV	PS-2-SKLV	PS-3-SKLV	PS-4-SKLV	PS-5-SKLV	PS-6-SKLV	PS-7-SKLV	PS-8-SKLV
Low Friction-Low Temperature (L, Q)	PS-1-SKLQ	PS-2-SKLQ	PS-3-SKLQ	PS-4-SKLQ	PS-5-SKLQ	PS-6-SKLQ	PS-7-SKLQ	PS-8-SKLQ

Deviations from Standard Dimensions (Options L, H, E, M)

‡ Heavy duty rear head is recommended for applications where the cylinder is mounted on the front face or trunnion-mounted, and impact loading (20 or more cycles/minute) occurs between the piston and rear head. It increases the overall length of the cylinder as shown.

† A minimum stroke of 3/8" is required to sense end-of-stroke positions. For low friction seals used in conjunction with magnetic position sensing, use "E" or "M" length adder only.

Bore	Length Adder (inches)				
	Low Friction Seals (L)	Heavy Duty Rear Head‡ (H)	Magnetic Position Sensing† (E or M)		
			PSD, PWD, PTD	PSR	PSX
1/2 (1)	0.25	0.13	0.88	0.63	0.38
3/4 (2)	0.25	0.13	0.88	0.88	0.88
1-1/16 (3)	0.38	0.19	0.88	0.88	0.88
1-1/2 (4)	0.38	0.19	0.88	0.88	0.88
2 (5)	0.38	0.19	0.88	0.88	0.88
2-1/2 (6)	0.38	0.25	0.88	0.88	0.88
3 (7)	0.50	0.25	0.88	0.88	0.88
4 (8)	0.50	0.38	0.88	0.88	0.88

Threaded Mounting Holes Available either or both ends.

1/2" Bore (HR shown)

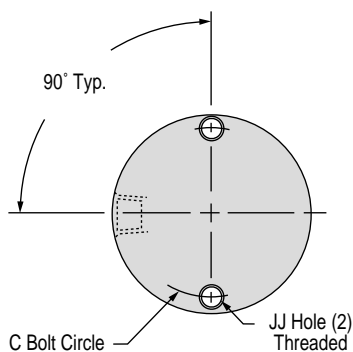

3/4" Bore & Up

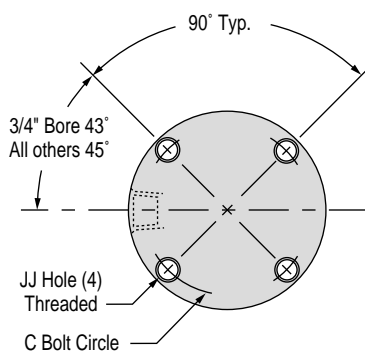

Nose Mount

Available on PSD, PSR, and PSX. (F shown) Includes rod wiper and heavy duty rear head. See length adder above.

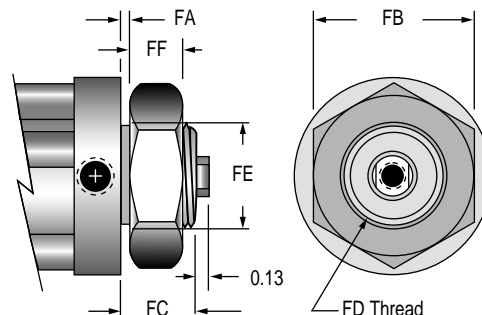

Dimensions (inches)

Bore	C	JJ	FA	FB	FC	FD	FE	FF
1/2 (1)	0.88	#4 – 40 UNC	.06	0.75 Hex	.38	1/2 – 20 UNF-2A	.50	.31
3/4 (2)	1.22	#6 – 32 UNC	.06	0.75 Hex	.38	5/8 – 18 UNF-2A	.62	.25
1-1/16 (3)	1.69	#6 – 32 UNC	.13	1.50 Hex	.75	1 – 14 UNF-2A	1.00	.55
1-1/2 (4)	2.19	#10 – 24 UNC	.13	1.88 Hex	.75	1-1/4 – 12 UNF-2A	1.25	.52
2 (5)	2.69	#10 – 24 UNC	.19	1.88 Hex	.88	1-3/8 – 12 UNF-2A	1.38	.52
2-1/2 (6)	3.25	1/4 – 20 UNC	.25	1.88 Hex	1.00	1-3/8 – 12 UNF-2A	1.38	.52
3 (7)	3.78	1/4 – 20 UNC	.25	1.88 Hex	1.00	1-3/8 – 12 UNF-2A	1.38	.52
4 (8)	4.94	5/16 – 18 UNC	.19	2.62 Hex	1.12	1-3/4 – 12 UN-2A	1.75	.88

Maximum Torque for Nose Mount Option

Bore	Foot-Pounds
1/2 (1)	12
3/4 (2)	28
1-1/16 (3)	100
1-1/2 (4)	120
2 (5)	130
2-1/2 (6)	130
3 (7)	130
4 (8)	150

Pancake® II Cylinders

Nonrotating, double acting 4 Bore sizes 3/4" thru 2" Strokes to 4" standard



Twin piston rods are incorporated into the cylinder head to achieve NON-ROTATION. The rods are securely fastened to the piston and tied together externally by a rod end tool bar. The tool bar insures that the rods move in tandem and provides an ideal mounting surface for any attachments required by your application. The tool bar is furnished with threaded mounting holes or optional counter-bored mounting holes.

Ratings – Standard Units all Series

- Body Self-lubricating composite
- Heads Clear anodized aluminum alloy
- Tie Bolts Stainless steel
- Rod Chrome plated stainless steel
- Piston Stainless steel
- Rod end Tool bar
- Ports Position #1
- Seals Internally lubricated Buna-N
- Lubrication Magnalube®-G
- Rod bushing Bronze
- Stroke tolerance ± 1/64"
- Media Air
- Pressure rating, maximum 200 psi
- Minimum recommended operating pressure 15 psi
- Temperature rating Cylinder -25° to +221°F (-32° to +105°C)
- Temperature rating Electronic sensors -4° to +176°F (-20° to +80°C)

Allowable Torsion Load and Rotational Tolerance

Side loading should be avoided for any cylinder application. The smaller diameter twin rods will have more deflection due to side load than the one standard rod in a comparable **Pancake® II** cylinder. However, the PND Series is designed to work satisfactorily against pure torsional loads. Maximum torsional load per bore size is shown in the following table.

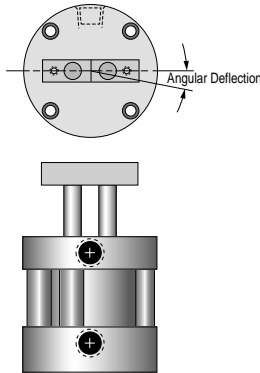

Approximate Angular Deflection (Degrees) due to max. torsional load							
Bore	Torsional Load Max.	Stroke					
		0 to 1-1/2	2	2-1/2	3	3-1/2	4
3/4	0.3 in-lbs	less than 0.22	0.51	0.98	1.67	2.62	3.88
1-1/16	1.0 in-lbs	less than 0.15	0.33	0.64	1.09	1.71	2.53
1-1/2	5.0 in-lbs	less than 0.08	0.18	0.36	0.61	0.95	1.41
2	10.0 in-lbs	less than 0.03	0.07	0.13	0.22	0.34	0.50

Freeplay Rotational Tolerance				
Bore	3/4" (2)	1-1/16" (3)	1-1/2" (4)	2" (5)
Max. Rotation	±1°	±3/4°	±1/2°	±1/2°

Cylinder Sizing Guide

Bore Diameter (inch)	3/4	1-1/16	1-1/2	2
Rod Diameter (inch)	0.19	0.25	0.38	0.50
Rod Area (in ²)	0.05	0.10	0.22	0.38
Push Area (in ²)	0.44	0.88	1.76	3.14
Pull Area (in ²)	0.39	0.78	1.54	2.76

How to Order

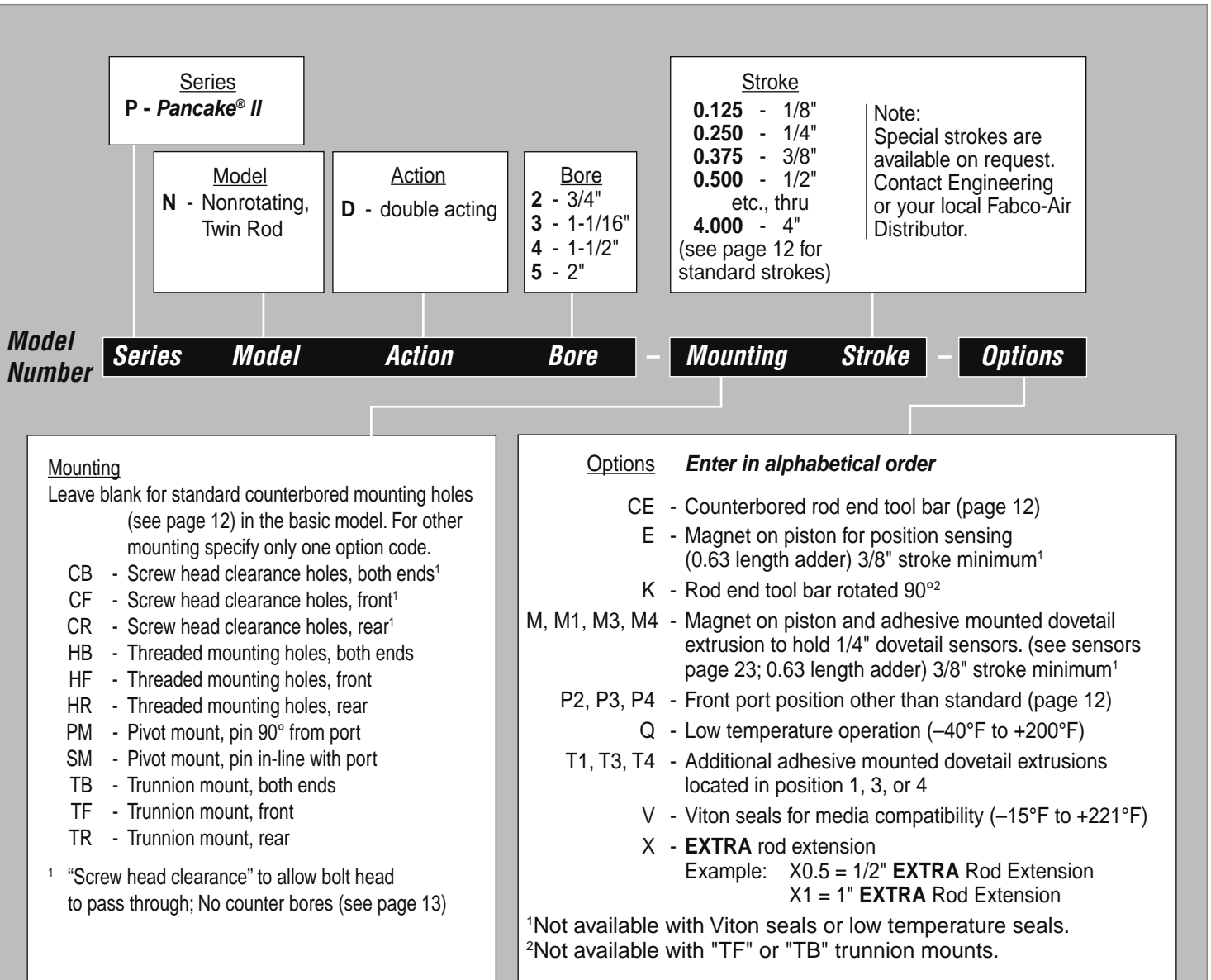

How to Order

1. Specify P, Model, Action and Bore
2. Specify optional Mounting (if required), then Stroke
3. Specify the Options in alphabetical order

Ordering example #1: **PND3-PM0.375-CE**

This model number specifies a **Pancake® II** nonrotating, double acting, cylinder with tool bar, 1-1/16" bore, pivot mounting, 3/8" stroke and counterbored rod end tool bar.

Ordering example #2: **PND5-2.000**

This model number specifies a **Pancake® II** nonrotating, double acting, cylinder with tool bar, 2" bore, standard counterbored mounting holes, and 2" stroke.

Pancake® II Cylinders

Basic Model PND

**Twin Rod, Nonrotating
 Double Acting**

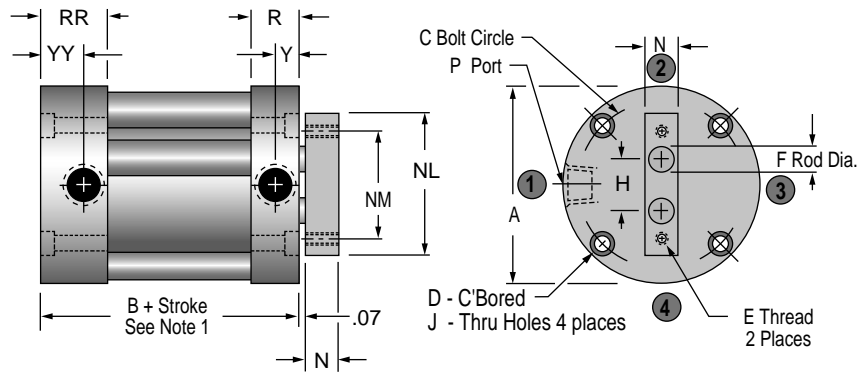

Note 1: Magnetic Position Sensing Length Adder = 0.63
 A minimum stroke of 3/8" is required to sense end-of-stroke positions

Standard Strokes – All Models: • 1/8 • 1/4 • 3/8 • 1/2 • 5/8 • 3/4 • 7/8 • 1 • 1-1/4 • 1-1/2 • 1-3/4 • 2 • 2-1/2 • 3 • 3-1/2 • 4
Special strokes available. Contact Engineering or your local Fabco-Air distributor for information.

Counterbored Rod End Tool Bar

Option CE

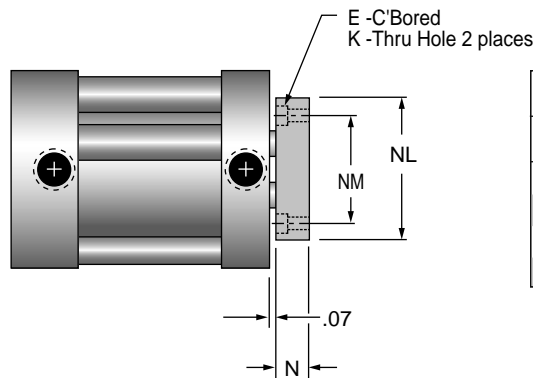

C'Bore Hole Dimensions (inches)

Bore	E C'Bore	K
3/4 (2)	0.24 x 0.15 dp	0.15
1-1/16 (3)	0.29 x 0.18 dp	0.18
1-1/2 (4)	0.40 x 0.27 dp	0.26
2 (5)	0.49 x 0.33 dp	0.33

Dimensions (inches)

Bore	A	B	C	D	E Thread	F	H	J	N	NL	NM	P	R	RR	Y	YY
3/4 (2)	1.49	0.94	1.22	0.24 x 0.15 dp	#6-32 UNC	0.19	0.332	0.15	0.38	1.25	0.88	#10-32 UNF	0.34	0.47	0.14	0.27
1-1/16 (3)	1.99	1.31	1.69	0.24 x 0.15 dp	#8-32 UNC	0.25	0.422	0.15	0.38	1.44	1.06	1/8 NPT	0.50	0.69	0.25	0.44
1-1/2 (4)	2.62	1.31	2.19	0.34 x 0.22 dp	1/4-20 UNC	0.38	0.562	0.20	0.50	2.00	1.50	1/8 NPT	0.50	0.69	0.25	0.44
2 (5)	3.12	1.38	2.69	0.34 x 0.22 dp	5/16-18 UNC	0.50	0.750	0.20	0.63	2.50	1.88	1/8 NPT	0.53	0.72	0.25	0.44

Nonrotating Series PND Dimensions & Options

Seal Kits – Series PND

Options	Kit Numbers by Bore Size			
	3/4"	1-1/16"	1-1/2"	2"
Standard	PN-2-SK	PN-3-SK	PN-4-SK	PN-5-SK
Viton (V)	PN-2-SKV	PN-3-SKV	PN-4-SKV	PN-5-SKV
Low Temperature (Q)	PN-2-SKQ	PN-3-SKQ	PN-4-SKQ	PN-5-SKQ

Mounting Options

Trunnion Mount

Available rear, front or both.
(TF shown solid)

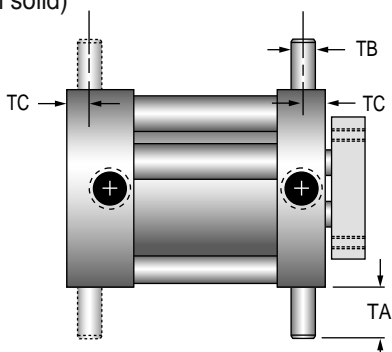

Pivot Mount

Complete with bronze pivot bushing.
Not available as an accessory. (SM shown)

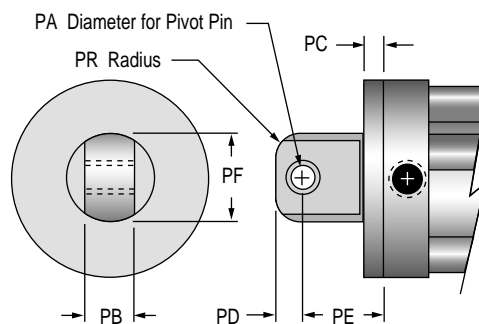

Threaded Mounting Holes

Available either or both ends. (HR shown)

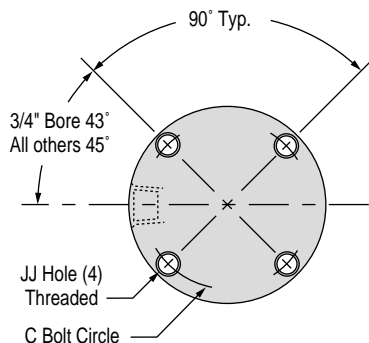

Screw Head Clearance Holes

Available either or both ends.
(CR shown)

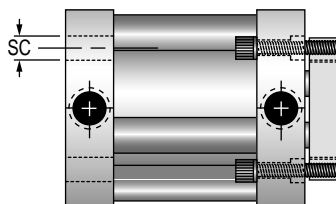

Approximate Cylinder Weights (ounces)

Bore	Base	Adder per 1/8 of Stroke
3/4 (2)	3.1	0.1
1-1/16 (3)	7.4	0.5
1-1/2 (4)	14.3	0.7
2 (5)	21.5	0.9

Dimensions (inches)

Bore	C	JJ	PA	PB	PC	PD	PE	PF	PR	SC	TA	TB	TC
3/4 (2)	1.22	#6-32 UNC	0.19	0.38	0.19	0.25	0.75	0.75	0.19	0.23	0.31	0.125	0.17
1-1/16 (3)	1.69	#6-32 UNC	0.19	0.38	0.25	0.25	0.81	0.75	0.19	0.25	0.50	0.250	0.25
1-1/2 (4)	2.19	#10-24 UNC	0.38	0.75	0.25	0.44	1.19	1.38	0.38	0.34	0.50	0.250	0.25
2 (5)	2.69	#10-24 UNC	0.38	0.75	0.31	0.44	1.25	1.38	0.38	0.34	0.50	0.250	0.25

Pancake® II Cylinders

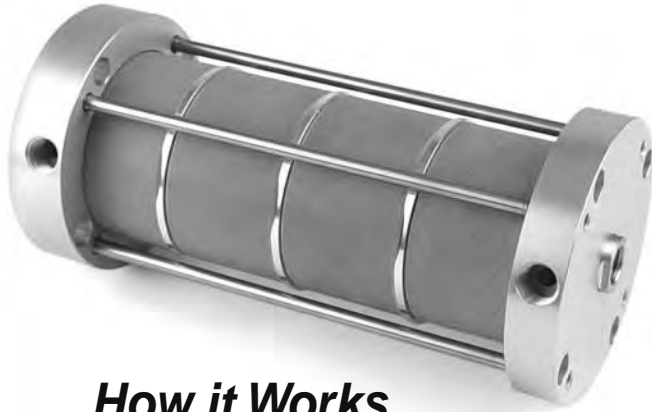

How it Works

PA Series shown

Fabco-Air attaches multiple pistons to a common shaft and provides internal air passages through the shaft to all pistons. When air pressure is applied to the extend port, all pistons are pressurized simultaneously, enabling tremendous thrust forces to be obtained. (See the handy cylinder sizing guide below for the force multiplying factors.) When air pressure is applied to the retract port only one piston is pressurized.

NOTE: 1) Series PB is made with multiple retract and single extend cylinder action for applications requiring high pulling force. See "How to Order" and "Sizing Guide".

2) Additional retract stages are offered in the PA Series (multiple extend and single retract) with the use of ported baffles. Contact engineering for application and information. Add 0.50" length to dimension B* for each ported baffle. See "Options" R2, R3, R4 listed on page 15.

Double acting, single rod end cylinders multiply force output. 3 Bore sizes 2-1/2" thru 4". Strokes to 4" standard.

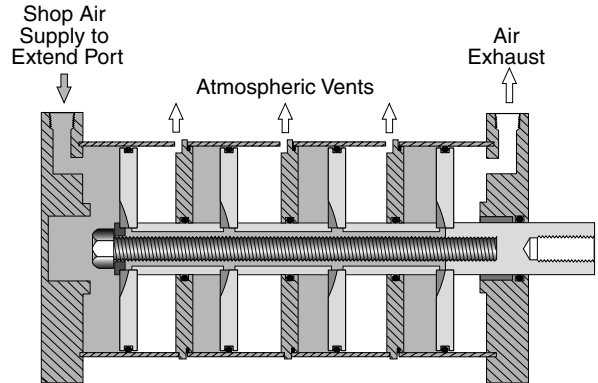

Extend Port - Air supplied to all pistons

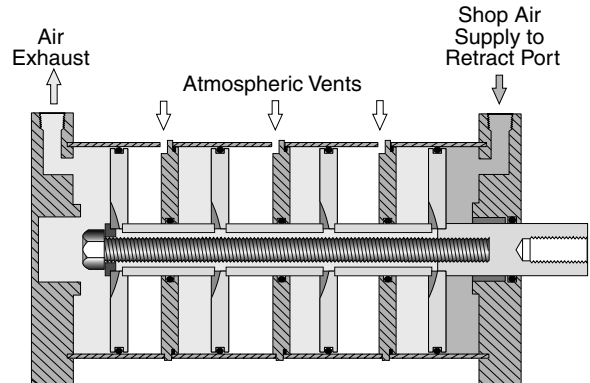

Retract Port - Air supplied to front piston only

Ratings – Standard Units all Series

- Body Self-lubricating composite
- Heads Clear anodized aluminum alloy
- Tie Bolts Stainless steel
- Rod Chrome plated stainless steel
- Piston Aluminum alloy
- Rod end Female thread with wrench flats
- Ports Position #1
- Seals Internally lubricated Buna-N
- Lubrication Magnalube®-G
- Rod bushing PTFE composite bearing
- Stroke tolerance $\pm 1/64"$ per stage
- Media Air
- Pressure rating, maximum 200 psi
- Minimum recommended operating pressure 15 psi
- Temperature rating
 Cylinder -25° to $+221^{\circ}$ F
 (-32° to $+105^{\circ}$ C)
- Temperature rating
 Electronic sensors -4° to $+176^{\circ}$ F
 (-20° to $+80^{\circ}$ C)

Cylinder Sizing Guide

Bore	Bore Model Designation	Extend Piston Area (in ²)			Retract Piston Area (in ²)
		PA2	PA3	PA4	
2-1/2	6	9.4	13.8	18.3	4.5
3	7	13.5	20.0	26.5	6.5
4	8	24.3	36.1	47.9	11.8

Bore	Bore Model Designation	Retract Piston Area (in ²)			Extend Piston Area (in ²)
		PB2	PB3	PB4	
2-1/2	6	8.9	13.4	17.9	4.9
3	7	12.9	19.4	25.9	7.1
4	8	23.6	35.3	47.1	12.6

How to Order

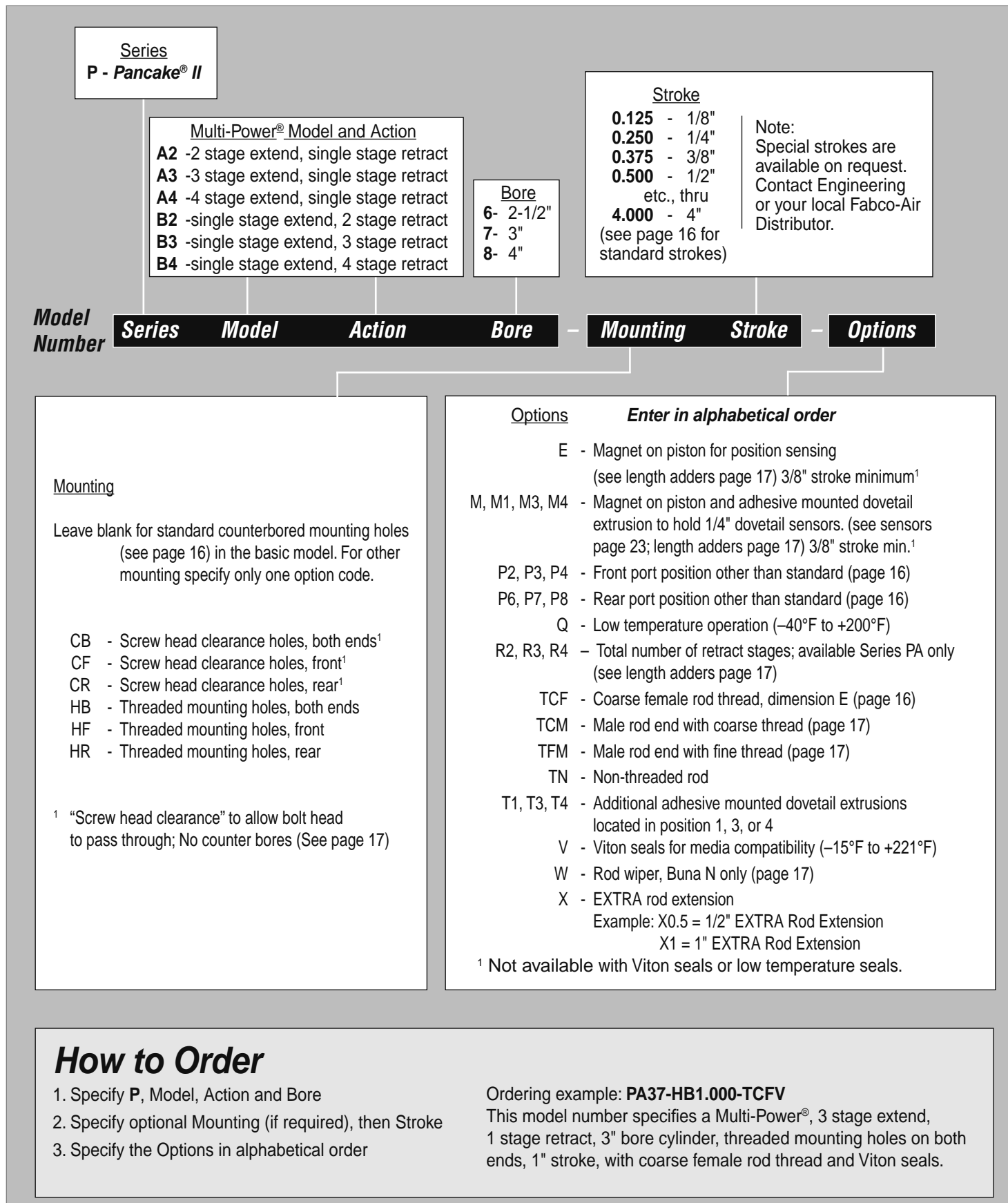

Pancake® II Cylinders

Model PA2 or PB2

Standard Strokes – All Models: • 1/8 • 1/4 • 3/8 • 1/2 • 5/8 • 3/4 • 7/8 • 1 • 1-1/4 • 1-1/2 • 1-3/4 • 2 • 2-1/2 • 3 • 3-1/2 • 4
Special strokes available on request. Contact Engineering or your local Fabco-Air Distributor

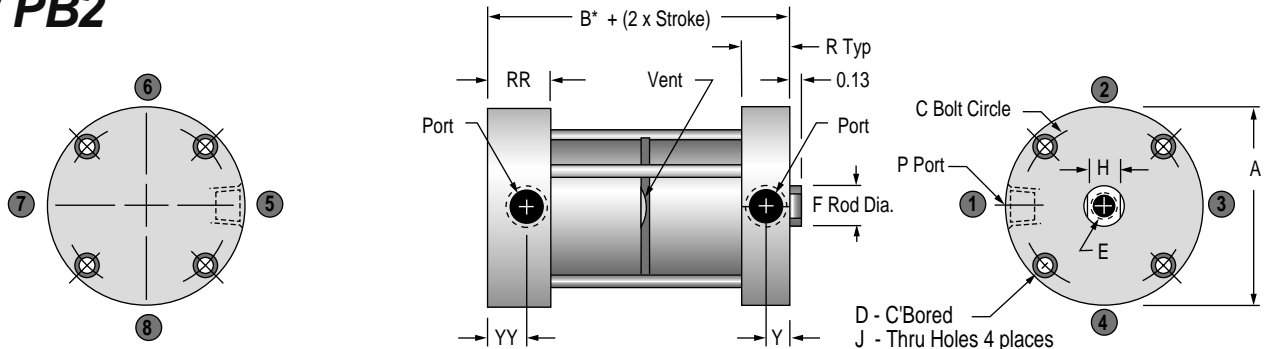

Model PA3 or PB3

Standard Strokes – All Models: • 1/8 • 1/4 • 3/8 • 1/2 • 5/8 • 3/4 • 7/8 • 1 • 1-1/4 • 1-1/2 • 1-3/4 • 2 • 2-1/2 • 3 • 3-1/2 • 4
Special strokes available on request. Contact Engineering or your local Fabco-Air Distributor

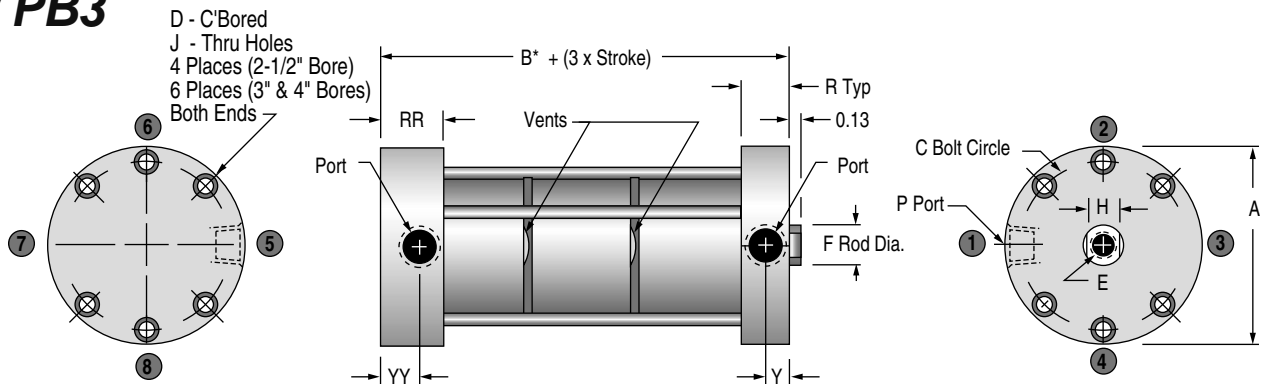

Model PA4 or PB4

Standard Strokes – All Models: • 1/8 • 1/4 • 3/8 • 1/2 • 5/8 • 3/4 • 7/8 • 1 • 1-1/4 • 1-1/2 • 1-3/4 • 2 • 2-1/2 • 3 • 3-1/2 • 4
Special strokes available on request. Contact Engineering or your local Fabco-Air Distributor

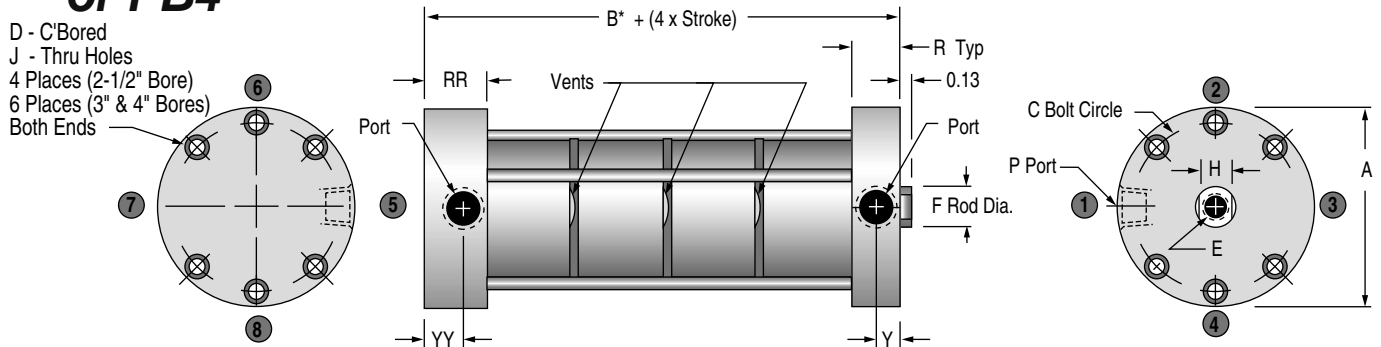

***Dimension "B" for Strokes .125, .188, and .250 (inches)**

Bore	.125 Stroke			.188 Stroke			.250 Stroke		
	PA2 or PB2	PA3 or PB3	PA4 or PB4	PA2 or PB2	PA3 or PB3	PA4 or PB4	PA2 or PB2	PA3 or PB2	PA4 or PB2
2-1/2 (6)	2.65	3.64	4.63	2.71	3.76	4.81	2.77	3.87	4.97
3 (7)	2.75	3.77	4.79	2.81	3.90	4.98	2.88	4.01	5.15
4 (8)	3.38	4.61	5.85	3.44	4.74	6.04	3.53	4.89	6.24

Dimensions (inches)

Bore	A	B* (strokes over .250)			C	D C'Bore	E Female Thread		E Depth for Stroke Range		F	H	J	P	R	RR	Y	YY
		PA2 or PB2	PA3 or PB3	PA4 or PB4			E Standard	E Course	1/8 - 1/2	5/8 +								
		2-1/2 (6)	3.75	2.29			3.15	4.02	3.25	0.40 x 0.27 dp								
3 (7)	4.25	2.39	3.28	4.18	3.78	0.40 x 0.27 dp	5/8-18 UNF	5/8-11 UNC	0.45-0.73	0.73	0.88	0.75	0.26	1/4 NPT	0.69	0.94	0.33	0.58
4 (8)	5.50	3.04	4.15	5.27	4.94	0.49 x 0.33 dp	3/4-16 UNF	3/4-10 UNC	0.40-0.70	0.80	1.00	0.88	0.33	3/8 NPT	0.84	1.22	0.42	0.80

Seal Kits - Multi-Power® Series PA & PB

Options	Kit Numbers by Stages and Bore Size								
	PM2-2½"	PM2-3"	PM2-4"	PM3-2½"	PM3-3"	PM3-4"	PM4-2½"	PM4-3"	PM4-4"
Standard	PM2-6-SK	PM2-7-SK	PM2-8-SK	PM3-6-SK	PM3-7-SK	PM3-8-SK	PM4-6-SK	PM4-7-SK	PM4-8-SK
Viton (V)	PM2-6-SKV	PM2-7-SKV	PM2-8-SKV	PM3-6-SKV	PM3-7-SKV	PM3-8-SKV	PM4-6-SKV	PM4-7-SKV	PM4-8-SKV
Low Temperature (Q)	PM2-6-SKQ	PM2-7-SKQ	PM2-8-SKQ	PM3-6-SKQ	PM3-7-SKQ	PM3-8-SKQ	PM4-6-SKQ	PM4-7-SKQ	PM4-8-SKQ

Mounting Options

Threaded Mounting Holes

Available either or both ends. (HR shown)

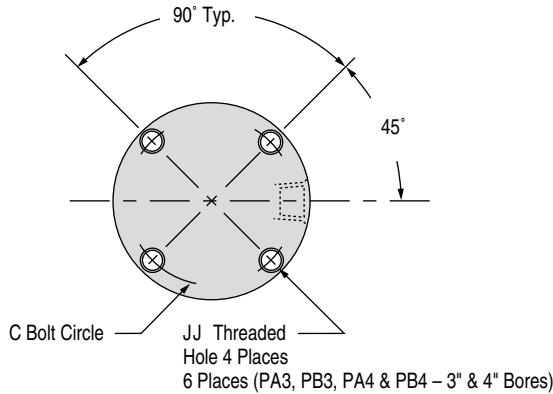

Screw Head Clearance Holes

Available either or both ends. (CR shown)

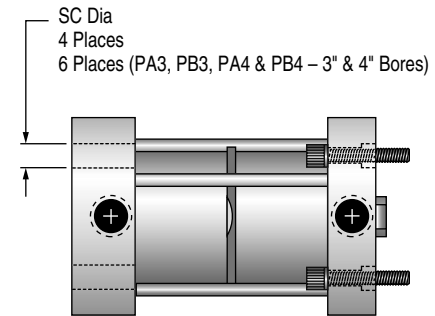

Model Options

Male Rod Ends
(Option TCM or Option TFM)
(Model PA2 shown)

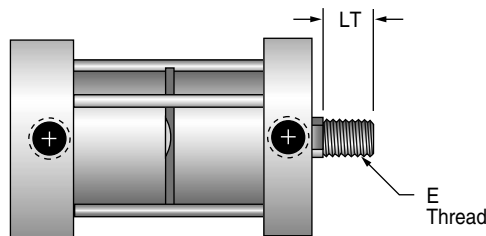

Rod Wiper
(Option W)

Buna-N only.
(Model PA2 shown)

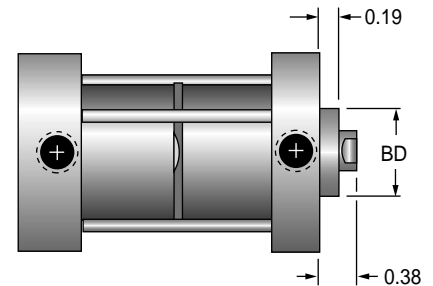

Approximate Cylinder Weights (ounces)

Bore	PA2, PB2		PA3, PB3		PA4, PB4	
	Base	Adder per 1/8 Stroke	Base	Adder per 1/8 Stroke	Base	Adder per 1/8 Stroke
2-1/2 (6)	37.2	1.2	53.3	1.8	69.4	2.4
3 (7)	49.9	1.6	71.0	2.4	92.1	3.2
4 (8)	93.1	2.0	133.8	3.0	174.5	4.0

Dimensions (inches)

Bore	BD	C	JJ	E Male Thread		LT	SC
				TCM (Coarse)	TFM (Fine)		
2-1/2 (6)	1.13	3.25	1/4 - 20 UNC	1/2-13 UNC	1/2-20 UNF	0.63	0.41
3 (7)	1.25	3.78	1/4 - 20 UNC	5/8-11 UNC	5/8-18 UNF	0.75	0.41
4 (8)	1.38	4.94	5/16 - 18 UNC	3/4-10 UNC	3/4-16 UNF	0.75	0.50

Length Adder for Options (inches)

Bore	Series	Magnetic Position Sensing† (E or M)	Ported Baffle	
			Retract Stages	Port Size
2-1/2	PA2, PB2	0.88	R2	0.50 ¼ NPT
	PA3, PB3		R3	1.00 ¼ NPT
	PA4, PB4		R4	1.50 ¼ NPT
3	PA2, PB2	0.88	R2	0.50 ¼ NPT
	PA3, PB3		R3	1.00 ¼ NPT
	PA4, PB4		R4	1.50 ¼ NPT
4	PA2, PB2	0.88	R2	0.50 ¼ NPT
	PA3, PB3		R3	1.00 ¼ NPT
	PA4, PB4		R4	1.50 ¼ NPT

† 1) A minimum stroke of 3/8" is required to sense end-of-stroke positions.
2) Magnet is applied to front piston.

Pancake® II Cylinders



**Double acting, single rod end
 Cylinder provides 3 positions
 8 Bore sizes 1/2" thru 4"
 Strokes to 4" standard**

Other multi-position cylinders (4 position, 5 position, etc.) are available as specials. Contact Engineering or your local Fabco-Air distributor for more information.

Ratings – Standard Units all Series

- Body Self-lubricating composite
- Heads Clear anodized aluminum alloy
- Tie Bolts Stainless steel
- Rod Chrome plated stainless steel
- Piston Aluminum alloy
- Rod end Female thread & wrench flats
- Ports Position #1
- Seals Internally lubricated Buna-N
- Lubrication Magnalube®-G
- Rod bushing PTFE composite bearing
- Stroke tolerance ± 1/64" per stroke
- Media Air
- Pressure rating, maximum 200 psi
- Minimum recommended operating pressure 15 psi
- Temperature rating Cylinder -25° to +221°F (-32° to +105°C)
- Temperature rating Electronic sensors -4° to +176°F (-20° to +80°C)

Cylinder Sizing Guide

Bore Diameter (inch)	1/2	3/4	1-1/16	1-1/2	2	2 1/2	3	4
Rod Diameter (inch)	0.25	0.31	0.50	0.63	0.75	0.75	0.88	1.00
Rod Area (in ²)	0.05	0.08	0.19	0.31	0.44	0.44	0.60	0.79
Push Area (in ²)	0.20	0.44	0.88	1.76	3.14	4.91	7.07	12.57
Pull Area (in ²)	0.15	0.36	0.69	1.45	2.66	4.47	6.47	11.78

How it Works

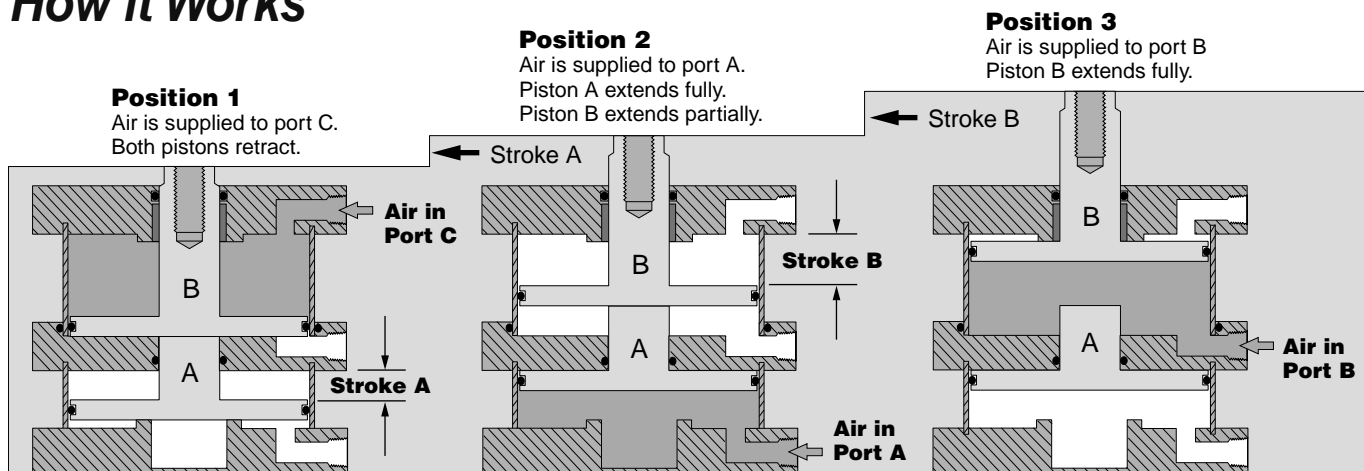

How to Order

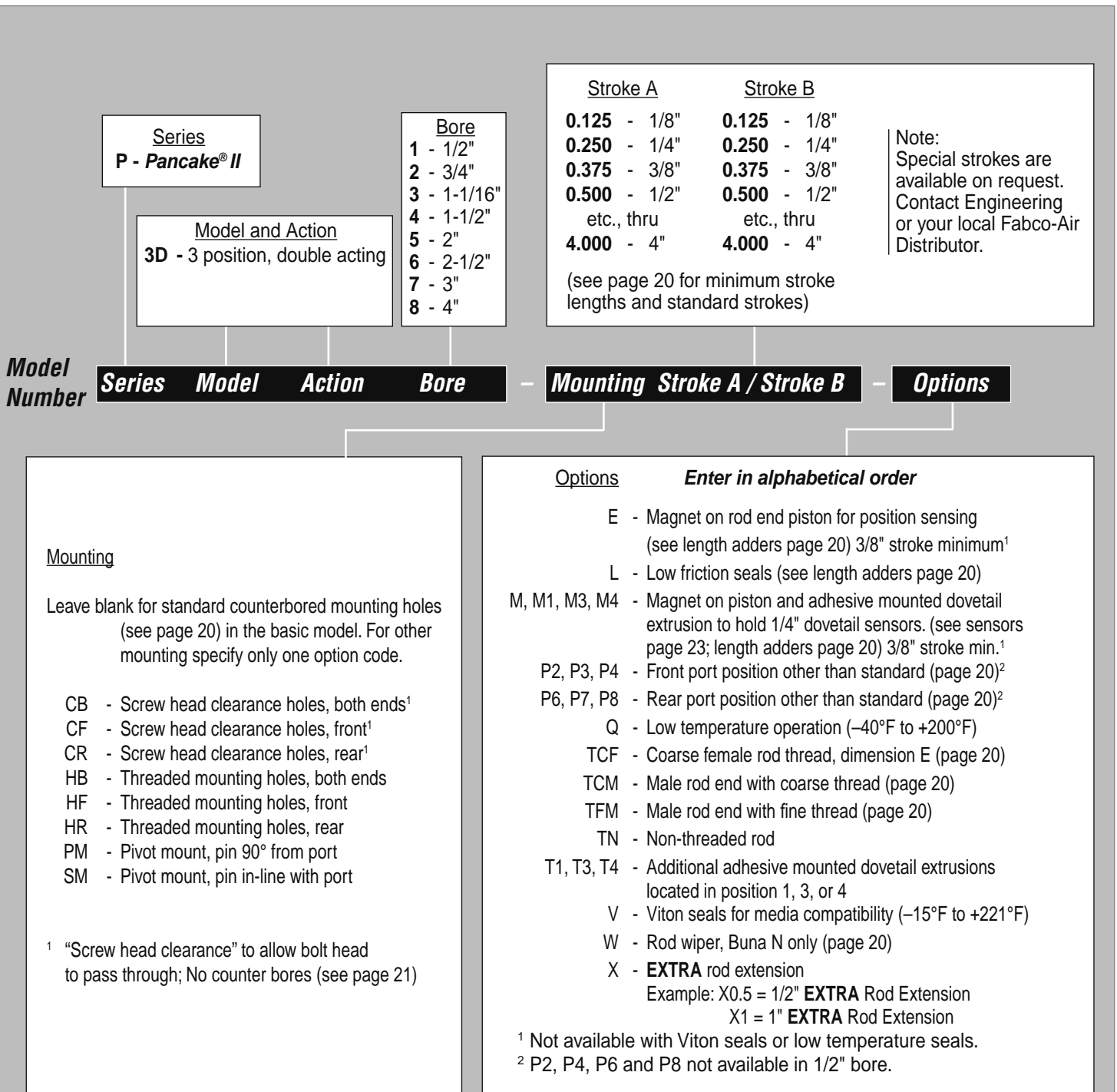

How to Order

1. Specify P, Model, Action and Bore
2. Specify optional Mounting (if required), then Stroke
3. Specify the Options desired

Ordering example: **P3D5-CR0.375/2.000-TCM**

This model number specifies a 3-position, double acting cylinder, 2" bore, screw clearance holes at rear, 3/8" stroke A, 2" stroke B, and male rod end with coarse thread.

Pancake® II Cylinders

Basic Model

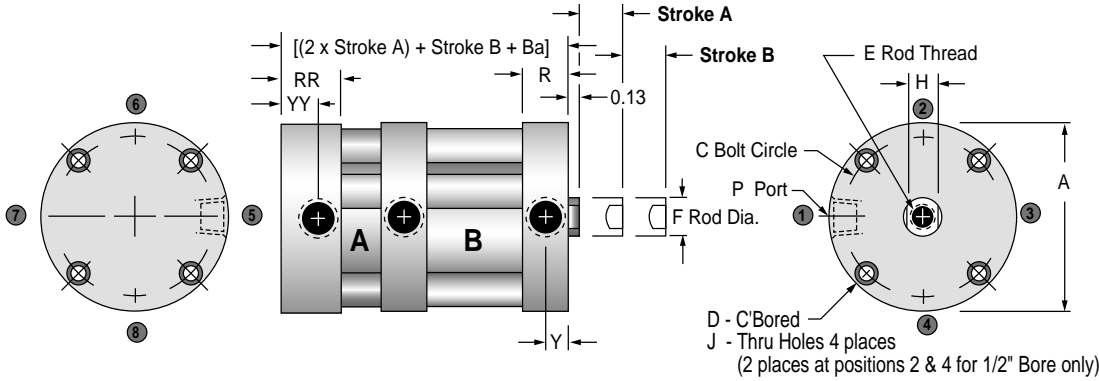

Bore	Base Model Stroke A
1/2 (1)	0.19
3/4 (2)	0.19
1-1/16 (3)	0.25
1-1/2 (4)	0.25
2 (5)	0.25
2-1/2 (6)	0.38
3 (7)	0.38
4 (8)	0.34

*Note:
1) No minimum for stroke B.
2) No minimum for stroke A or B with Low Friction Option -L

Standard Strokes -- • 1/8 • 1/4 • 3/8 • 1/2 • 5/8 • 3/4 • 7/8 • 1 • 1-1/4 • 1-1/2 • 1-3/4 • 2 • 2-1/2 • 3 • 3-1/2 • 4
Special strokes available on request. Contact Engineering or your local Fabco-Air Distributor

Model Options

Rod Wiper (Option W)

Buna-N only.

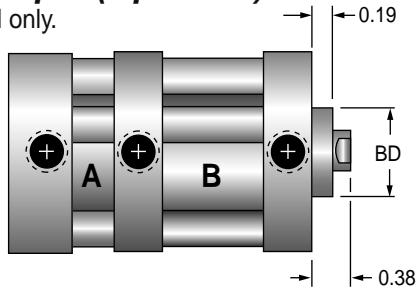

Male Rod Ends (Option TCF or TFM)

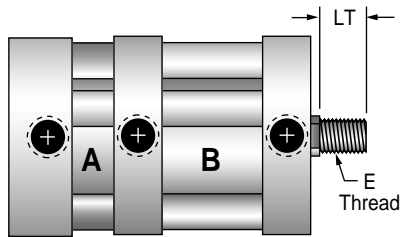

Deviations from Standard Dimensions (Options L, E, M)

Bore	Low Friction Seals (L)	Magnetic Position Sensing [†] (E or M)	Low Friction Seals & Magnetic Position Sensing [†] (EL or LM)
1/2 (1)	0.50	0.88	1.13
3/4 (2)	0.50	0.88	1.13
1-1/16 (3)	0.75	0.88	1.25
1-1/2 (4)	0.75	0.88	1.25
2 (5)	0.75	0.88	1.25
2-1/2 (6)	0.75	0.88	1.25
3 (7)	1.00	0.88	1.38
4 (8)	1.00	0.88	1.38

†1) A minimum stroke of 3/8" is required to sense end-of-stroke positions.
2) Magnet is applied to piston of stroke B.

Dimensions (inches)

Bore	A	Ba	BD	C	D C'Bore	E Female Thread		E Depth for Stroke Range		F	H	J	LT	P	R	RR	Y	YY
						E Standard	E Course	1/8 - 1/2	5/8 +									
1/2 (1)	1.12	1.14	0.56	0.88	0.20 x 0.13 dp	#8-32 UNC	N/A	0.30-0.46	0.46	0.25	0.22	0.13	0.38	#10-32 UNF	0.34	0.47	0.14	0.27
3/4 (2)	1.49	1.14	0.69	1.22	0.24 x 0.15 dp	#10-32 UNF	#10-24 UNC	0.30-0.46	0.46	0.31	0.25	0.15	0.38	#10-32 UNF	0.34	0.47	0.14	0.27
1-1/16 (3)	1.99	1.67	0.88	1.69	0.24 x 0.15 dp	5/16-24 UNF	5/16-18 UNC	0.37-0.63	0.70	0.50	0.44	0.15	0.50	1/8 NPT	0.50	0.69	0.25	0.44
1-1/2 (4)	2.62	1.70	1.00	2.19	0.34 x 0.22 dp	3/8-24 UNF	3/8-16 UNC	0.37-0.70	0.70	0.63	0.50	0.20	0.50	1/8 NPT	0.50	0.69	0.25	0.44
2 (5)	3.12	1.80	1.13	2.69	0.34 x 0.22 dp	1/2-20 UNF	1/2-13 UNC	0.30-0.63	0.70	0.75	0.63	0.20	0.63	1/8 NPT	0.53	0.72	0.25	0.44
2-1/2 (6)	3.75	2.25	1.13	3.25	0.40 x 0.27 dp	1/2-20 UNF	1/2-13 UNC	0.42-0.70	0.70	0.75	0.63	0.26	0.63	1/4 NPT	0.66	0.91	0.33	0.58
3 (7)	4.25	2.34	1.25	3.78	0.40 x 0.27 dp	5/8-18 UNF	5/8-11 UNC	0.45-0.73	0.73	0.88	0.75	0.26	0.75	1/4 NPT	0.69	0.94	0.33	0.58
4 (8)	5.50	3.00	1.38	4.94	0.49 x 0.33 dp	3/4-16 UNF	3/4-10 UNC	0.40-0.70	0.80	1.00	0.88	0.33	0.75	3/8 NPT	0.84	1.22	0.42	0.80

Seal Kits - Multi-Position Series P3D

Options	Kit Numbers by Bore Size							
	1/2"	3/4"	1-1/16"	1-1/2"	2"	2-1/2"	3"	4"
Standard	P3-1-SK	P3-2-SK	P3-3-SK	P3-4-SK	P3-5-SK	P3-6-SK	P3-7-SK	P3-8-SK
Viton (V)	P3-1-SKV	P3-2-SKV	P3-3-SKV	P3-4-SKV	P3-5-SKV	P3-6-SKV	P3-7-SKV	P3-8-SKV
Low Temperature (Q)	P3-1-SKQ	P3-2-SKQ	P3-3-SKQ	P3-4-SKQ	P3-5-SKQ	P3-6-SKQ	P3-7-SKQ	P3-8-SKQ
Low Friction (L)	P3-1-SKL	P3-2-SKL	P3-3-SKL	P3-4-SKL	P3-5-SKL	P3-6-SKL	P3-7-SKL	P3-8-SKL
Low Friction-Viton (L, V)	P3-1-SKLV	P3-2-SKLV	P3-3-SKLV	P3-4-SKLV	P3-5-SKLV	P3-6-SKLV	P3-7-SKLV	P3-8-SKLV
Low Friction-Low Temperature (L, Q)	P3-1-SKLQ	P3-2-SKLQ	P3-3-SKLQ	P3-4-SKLQ	P3-5-SKLQ	P3-6-SKLQ	P3-7-SKLQ	P3-8-SKLQ

Mounting Options

Threaded Mounting Holes

Available either or both ends. (HR shown)

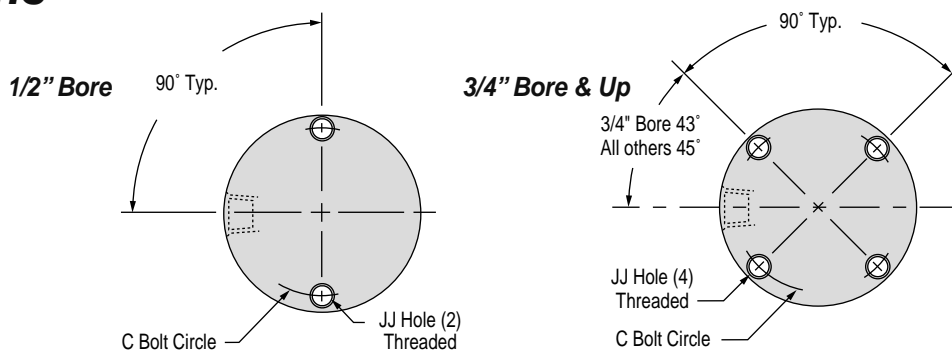

Screw Head Clearance Holes

Available either or both ends. (CR shown)
Screw head clearance holes are standard on all center sections.

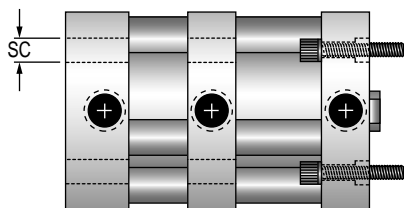

Pivot Mount

Complete with bronze pivot bushing. (SM shown)
Not available as an accessory

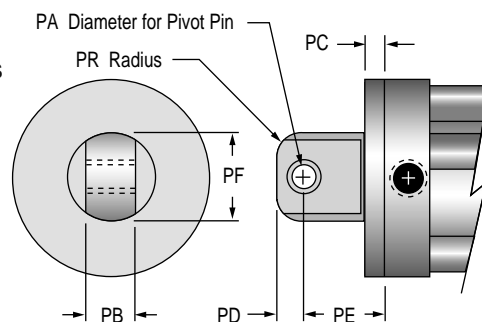

Dimensions (inches)

Bore	C	JJ	PA	PB	PC	PD	PE	PF	PR	SC
1/2 (1)	0.88	#4-40 UNC	0.19	0.38	0.19	0.25	0.75	0.63	0.19	0.17
3/4 (2)	1.22	#6-32 UNC	0.19	0.38	0.19	0.25	0.75	0.75	0.19	0.23
1-1/16 (3)	1.69	#6-32 UNC	0.19	0.38	0.25	0.25	0.81	0.75	0.19	0.25
1-1/2 (4)	2.19	#10-24 UNC	0.38	0.75	0.25	0.44	1.19	1.38	0.38	0.34
2 (5)	2.69	#10-24 UNC	0.38	0.75	0.31	0.44	1.25	1.38	0.38	0.34
2-1/2 (6)	3.25	1/4-20 UNC	0.38	0.75	0.38	0.44	1.31	1.38	0.38	0.41
3 (7)	3.78	1/4-20 UNC	0.63	1.00	0.38	0.56	1.69	1.88	0.38	0.41
4 (8)	4.94	5/16-18 UNC	0.63	1.00	0.44	0.56	1.75	1.88	0.38	0.50

Approximate Cylinder Weights (ounces)

Bore	Base	Adder per 1/8 of Stroke
1/2 (1)	3.3	0.16
3/4 (2)	4.5	0.2
1-1/16 (3)	9.9	0.6
1-1/2 (4)	18.7	0.8
2 (5)	24.5	1.0
2-1/2 (6)	41.3	1.2
3 (7)	52.9	1.6
4 (8)	102.7	2.0

Selection Guide

Accessory	Standard Series	PND Series	Multi-Power Series	P3D Series
Clevis Bracket	✓	✓	N/A	✓
Trunnion Bracket	✓	✓	N/A	N/A
Rod Eye	✓	N/A	✓	✓

Clevis Bracket

Anodized aluminum alloy
Chrome plated steel pin included

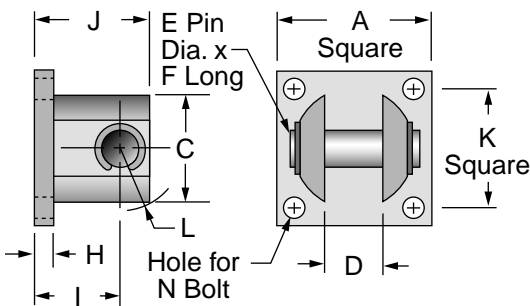

The bracket is intended for mounting with either a rod pivot or pivot mount; it is not intended to mount directly with the rear cylinder head.

Dimensions (inches)

Kit No.	Bore	A	C	D	E	F	H	I	J	K	L	N
CB-3	1/2 (1)	1.00	0.71	0.39	0.187	0.93	0.16	0.56	0.78	0.75	0.42	#6
	3/4 (2)											
	1-1/16 (3)											
CB-6	1-1/2 (4)	1.75	1.37	0.75	0.375	1.63	0.22	0.94	1.34	1.38	0.80	#10
	2 (5)											
	2-1/2 (6)											
CB-8	3 (7)	2.50	2.10	1.00	0.625	2.42	0.25	1.25	1.81	2.00	1.19	1/4
	4 (8)											

Trunnion Bracket (pair)

Anodized aluminum alloy
complete with bronze pivot bushings

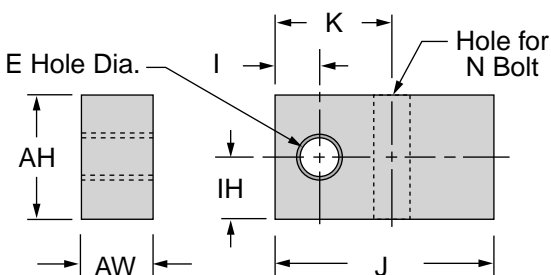

Dimensions (inches)

Kit No.	Bore	AH	AW	E	I	IH	J	K	N
TB-2	3/4 (2)	0.63	0.31	0.126	0.22	0.30	1.12	0.56	#10
TB-5	1-1/16 (3)	0.88	0.50	0.251	0.31	0.38	1.50	0.81	1/4
	1-1/2 (4)								
TB-7	2 (5)	1.00	0.63	0.313	0.38	0.45	1.63	0.94	5/16
	2-1/2 (6)								
TB-8	4 (8)	1.25	0.75	0.376	0.44	0.55	1.88	1.06	3/8

Rod Eye

Steel with bronze pivot bushing and nut

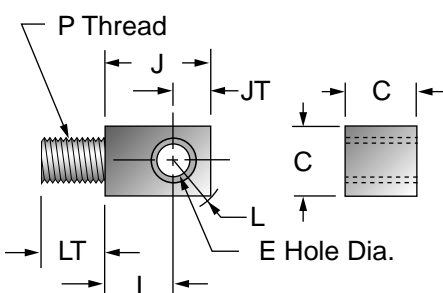

Dimensions (inches)

Kit No.	Bore	C	E	I	J	JT	L	LT	P
RE-1	1/2 (1)	0.38	0.187	0.47	0.72	0.25	0.32	0.38	#8-32 UNC
RE-2	3/4 (2)	0.38	0.187	0.47	0.72	0.25	0.32	0.38	#10-32 UNF
RE-3	1-1/16 (3)	0.38	0.187	0.47	0.72	0.25	0.32	0.63	5/16-24 UNF
RE-4	1-1/2 (4)	0.75	0.375	0.72	1.16	0.44	0.58	0.63	3/8-24 UNF
RE-6	2 (5)	0.75	0.375	0.72	1.16	0.44	0.58	0.75	1/2-20 UNF
	2-1/2 (6)								
RE-7	3 (7)	1.00	0.625	1.00	1.63	0.63	0.80	0.88	5/8-18 UNF
RE-8	4 (8)	1.00	0.625	1.00	1.63	0.63	0.80	0.88	3/4-16 UNF

Sensor Specifications & Ordering Information

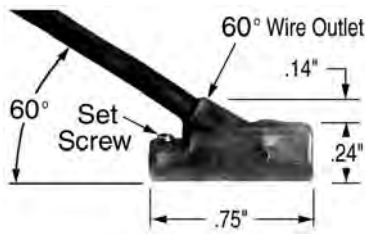

- Encased in a plastic housing, dovetail style electronic sensors are corrosion resistant. 60° wire outlet allows close mounting.
- Two methods of mounting are available:
 - Tie bolt spacer mounted clamps (Option -E)
 - Adhesive mounted dovetail extrusions (Option -M)
- Order sensors separately from the table below

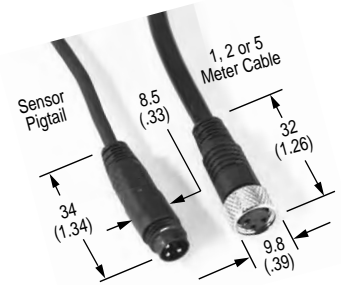

Ordering Guide – Dovetail Style Magnetic Sensor with LED				Sensor Temperature Range -20° to +80° C (-4° to +176° F)	Female Cordsets for Quick Disconnect								
Sensor Type	Prewired 9 ft. Part No.	Quick Disconnect Part No.*	Wire Leads	Electrical Characteristics									
Electronic	949-000-031	949-000-331	3	Sourcing PNP 6-24 VDC, 0.20 Amp Max current, 0.5 Voltage Drop	<table border="1"> <thead> <tr> <th>Length</th> <th>Part No.</th> </tr> </thead> <tbody> <tr> <td>1 Meter</td> <td>CFC-1M</td> </tr> <tr> <td>2 Meters</td> <td>CFC-2M</td> </tr> <tr> <td>5 Meters</td> <td>CFC-5M</td> </tr> </tbody> </table>	Length	Part No.	1 Meter	CFC-1M	2 Meters	CFC-2M	5 Meters	CFC-5M
Length	Part No.												
1 Meter	CFC-1M												
2 Meters	CFC-2M												
5 Meters	CFC-5M												
Electronic	949-000-032	949-000-332	3	Sinking NPN 6-24 VDC, 0.20 Amp Max current, 0.5 Voltage Drop									

Note: Quick disconnect styles are supplied with 6 inch pigtail with male connector. Order female cordsets separately.*

Option -E Magnet on piston – use spacer mounted clamps

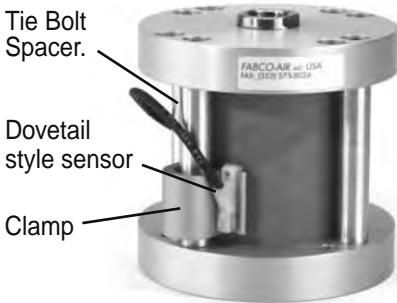

To apply dovetail style sensors first locate clamp in rough position on any of the tie bolt spacers or tie rods and lock it in place with the set screw.

Next, make fine adjustment by sliding the sensor within the clamp and lock in place with its set screw.

Clamp Selection Guide for Standard, Twin Rod & 3-Position Series						
Kit No.	SC-1	SC-2	SC-3	SC-5	SC-7	SC-8
To Fit Bore	1/2	3/4	1-1/16	1-1/2 & 2	2-1/2 & 3	4

Clamp Selection Guide for MultiPower® Series	
Kit No.	900-G00-000
To Fit Bore	All bore sizes

Order clamps and sensors separately

Option -M Magnet on piston and adhesive mounted dovetail extrusions

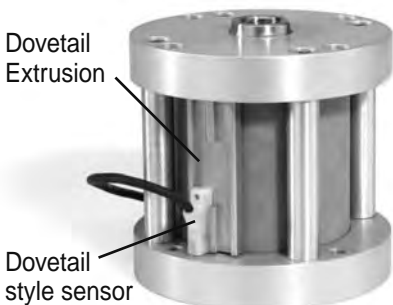

Specify Option M for mounting rail(s) located in standard position(2).

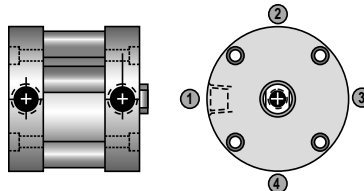

Specify option M1, M3, or M4 for mounting rail in alternate positions 1, 3, or 4 respectively. Additional dovetail rails may be applied by specifying options T1, T3, or T4.

The design and construction of the **Pancake II** allows the cylinder barrel to float approximately 0.020 axially. It can also rotate slightly. The axial movement will be more noticeable than the rotational movement during cylinder cycling and may present what appears to be sensor

Standard Dovetail Rail Positions		
Bore	Stroke Range	Position
1/2"	3/8" to 1-1/4"	1 & 3
1/2"	1-1/2" & above	1
3/4"	3/8" to 1-1/4"	2 & 4 [‡]
3/4"	1-1/2" & above	2
1-1/16" & up	3/8" & above	2

[‡]Note: When alternate positions are specified, the second of two required dovetail rails will be applied at position 2. (Contact factory for other combinations.)

malfunction when using the extruded dovetail rail. Thus, for extremely precise sensor applications where this may be troublesome, it is recommended to use the spacer-mounted clamps shown above in the -E option to provide a more stable and rigid sensor mount.



Pancake® II Cylinders

Series PSD, PSR, PSX, PWD, PTD

Basic Model	Base Price by Bore Size							
	1/2 (1)	3/4 (2)	1-1/16 (3)	1-1/2 (4)	2 (5)	2-1/2 (6)	3 (7)	4 (8)
PSD	\$40.35	\$41.70	\$54.10	\$64.30	\$74.15	\$94.15	\$115.90	\$170.80
PSR (0 to 1" Stroke)	43.25	45.95	59.60	69.00	79.35	100.75	124.15	183.75
PSR (1-1/8 to 4" Stroke)	47.35	48.90	63.25	74.20	84.60	109.35	132.70	192.35
PSX (0 to 1" Stroke)	51.90	53.50	68.05	81.80	92.25	114.30	138.35	204.90
PSX (1-1/8 to 4" Stroke)	53.05	54.90	69.50	87.00	97.40	122.90	146.95	212.70
Add per 1/8" of Stroke (PSD, PSR, PSX)	0.25	0.25	0.35	0.45	0.70	0.95	1.00	1.25
PWD	58.55	60.20	75.70	93.15	107.00	132.50	159.55	226.30
Add per 1/8" of Stroke	0.30	0.30	0.40	0.70	0.95	1.05	1.15	1.50
PTD	63.45	65.55	81.80	99.25	115.75	141.30	169.45	239.05
Add per 1/8" of Stroke	0.30	0.30	0.40	0.70	0.95	1.05	1.15	1.50

Mounting Options	Adders by Bore Size							
	1/2 (1)	3/4 (2)	1-1/16 (3)	1-1/2 (4)	2 (5)	2-1/2 (6)	3 (7)	4 (8)
CB, CF, CR (Screw Head Clearance Holes)	2.40	2.50	2.50	2.50	2.50	2.50	2.50	2.50
	per end	per end	per end	per end	per end	per end	per end	per end
F (Nose Mount)	5.50	6.35	21.30	23.70	30.40	33.45	35.60	47.25
HB, HF, HR (Threaded Mounting Holes)	2.85	2.95	3.15	3.95	3.95	4.60	4.60	5.65
	per end	per end	per end	per end	per end	per end	per end	per end
PM, SM (Pivot Mount)	10.95	11.55	13.40	18.20	21.15	27.25	32.75	44.75
TB, TF, TR (Trunnion Mount)	NA	9.60	9.60	9.60	9.60	10.90	10.90	11.50
		per end	per end	per end	per end	per end	per end	per end

Options	Adders by Bore Size							
	1/2 (1)	3/4 (2)	1-1/16 (3)	1-1/2 (4)	2 (5)	2-1/2 (6)	3 (7)	4 (8)
No charge for Options								
H, P2, P3, P4, TCF, TN								
B (both ends)	9.75	9.75	20.65	20.65	27.40	27.65	27.65	45.65
BF (front only)	6.05	6.05	14.55	14.55	21.30	21.30	21.30	34.05
BR (rear only)	3.70	3.70	6.05	6.05	6.05	6.35	6.35	11.55
E (Magnetic Piston Sensing)	4.50	4.50	4.50	6.65	11.15	14.80	19.40	22.00
J (with Standard Seals)	NA	0.10	0.20	0.20	0.25	0.25	0.25	0.30
J (with Viton Seals)	NA	0.45	0.65	0.65	0.90	0.90	1.05	2.90
L (Low Friction Seals)	3.20	3.30	4.10	4.60	5.50	6.75	7.80	9.25
M, M1, M3, M4 (Mag. Piston Sensing)	5.95	5.95	5.95	8.75	14.75	22.05	26.55	29.30
Q (Low Temperature Seals)								
Single Acting	2.00	2.55	3.15	4.00	5.00	6.20	7.80	9.80
Reverse Acting	2.30	2.85	3.55	4.40	5.50	6.90	8.60	10.75
Double Acting	2.35	2.90	3.70	4.55	5.70	7.15	8.95	11.25
Double End Rod	2.90	3.70	4.55	5.70	7.15	8.95	11.25	14.05
Q (Low Temp. Seals with L Option)								
Single Acting	4.35	5.50	6.85	8.55	10.70	13.45	16.80	21.05
Reverse Acting	4.80	6.05	7.55	9.45	11.75	14.80	18.50	23.15
Double Acting	5.00	6.20	7.80	9.85	12.35	15.45	19.25	24.15
Double End Rod	6.20	7.80	9.85	12.35	15.35	19.25	24.15	30.25
TCM, TFM (Male Rod Thread each end)	3.85	4.00	4.45	4.80	6.80	6.80	8.05	9.60
T1, T3, T4 (Switch Mounting Rail per rail)	2.25	2.25	2.90	2.90	2.90	3.60	3.60	3.60
V (with Standard Seals)								
Single Acting	1.80	1.85	3.30	5.55	7.40	10.70	14.80	20.30
Reverse Acting	2.50	2.80	4.45	6.90	8.75	12.00	16.55	22.05
Double Acting	3.75	3.95	5.80	9.25	12.20	16.60	24.40	30.50
Double End Rod	4.50	4.65	6.95	10.55	13.60	17.90	26.20	32.45
V (with Low Friction Seals)								
Single Acting	5.35	5.50	9.25	11.55	18.65	24.10	27.65	35.90
Reverse Acting	6.00	6.15	10.35	13.10	20.00	25.45	30.05	37.65
Double Acting	10.80	11.00	17.55	21.85	34.70	43.85	51.40	61.85
Double End Rod	11.40	11.60	18.60	23.15	36.15	45.10	53.20	63.65
W (Rod Wiper single end)	6.65	7.05	8.60	9.20	10.80	11.45	13.15	13.90
W (Rod Wiper double end)	13.30	14.00	17.30	18.20	21.50	22.85	26.45	27.85
X (each 1/2" or fraction thereof - each end)	0.60	0.60	0.80	0.95	1.20	1.20	1.30	1.65

Pancake® II - Nonrotating Series PND

Basic Model	Base Price by Bore Size			
	3/4 (2)	1-1/16 (3)	1-1/2 (4)	2 (5)
PND	\$62.30	\$81.70	\$96.80	\$111.85
Adder per 1/8" of stroke	0.30	0.40	0.65	0.85

Mounting Options	Adders by Bore Size			
	3/4 (2)	1-1/16 (3)	1-1/2 (4)	2 (5)
CB, CF, CR (Screw Head Clearance Holes)	\$2.50 per end	\$2.50 per end	\$2.50 per end	\$2.50 per end
HB, HF, HR (Threaded Mounting Holes)	2.95 per end	3.15 per end	3.95 per end	3.95 per end
PM, SM (Pivot Mount)	11.55	13.40	18.20	21.15
TB, TF, TR (Trunnion Mount)	9.60 per end	9.60 per end	9.60 per end	9.60 per end

Options	Adders by Bore Size			
	3/4 (2)	1-1/16 (3)	1-1/2 (4)	2 (5)
No charge for Options CE, K, P2, P3, P4				
E (Magnetic Piston Sensing)	\$4.50	\$4.50	\$6.65	\$11.15
M, M1, M3, M4 (Mag. Piston Sensing)	5.95	5.95	8.75	14.75
Q (Low temperature seals)	5.15	6.35	8.05	10.00
T1, T3, T4 (Switch mounting rail per rail)	2.25	2.90	2.90	2.90
V (Viton Seals)	12.00	18.95	23.50	36.60
X (each 1/2" or fraction thereof)	0.60	0.80	0.95	1.20

Pancake® II Multi-Power® Series PA & PB

Basic Model	Base Price by Bore Size		
	2-1/2 (6)	3 (7)	4 (8)
PA2 or PB2	\$155.35	\$194.20	\$281.95
Add per 1/8" of Stroke	2.70	3.35	4.10
PA3 or PB3	223.45	266.25	354.55
Add per 1/8" of Stroke	4.05	4.50	5.05
PA4 or PB4	272.60	324.75	433.30
Add per 1/8" of Stroke	4.90	5.45	6.10

Mounting Options	Adders by Bore Size		
	2-1/2 (6)	3 (7)	4 (8)
CB, CF, CR (Screw Head Clearance Holes)	\$2.50 per end	\$2.50 per end	\$2.50 per end
HB, HF, HR (Threaded Mounting Holes)	4.60 per end	4.60 per end	5.65 per end

Options	Adders by Bore Size		
	2-1/2 (6)	3 (7)	4 (8)
No charge for Options P2 thru P8, TCF, TN,			
E (Magnetic Piston Sensing)	\$14.80	\$19.40	\$22.00
M, M1, M3, M4 (Mag. Piston Sensing)	22.05	26.55	29.30
Q (Low Temperature Seals)			
PA2	12.55	15.70	19.70
PA3	22.00	27.45	34.45
PA4	38.50	48.05	60.25
R (Ported Baffle)			
R2	17.50	18.45	29.70
R3	35.00	36.90	59.40
R4	52.50	55.35	89.10
TCM, TFM (Male Rod Thread)	6.80	8.05	9.60
T1, T3, T4 (Switch Mounting Rail per rail)	3.60	3.60	3.60
PA2	20.70	30.40	38.10
V (Viton Seals)			
PA3	31.05	45.65	57.25
PA4	41.45	60.80	76.35
W (Rod Wiper)	11.45	13.15	13.90
X (Rod extension each 1/2" or fraction thereof)	1.20	1.30	1.65

Multi-Position Series P3D

Basic Model	Base Price by Bore Size							
	1/2 (1)	3/4 (2)	1-1/16 (3)	1-1/2 (4)	2 (5)	2-1/2 (6)	3 (7)	4 (8)
P3D	\$68.05	\$71.45	\$87.00	\$103.00	\$118.15	\$145.85	\$198.75	\$264.65
*Total combined stroke adder (per 1/8")	0.30	0.30	0.40	0.60	0.90	1.00	1.10	1.25

*Total combined stroke = (2 x Stroke A) + Stroke B

Mounting Options	Adders by Bore Size							
	1/2 (1)	3/4 (2)	1-1/16 (3)	1-1/2 (4)	2 (5)	2-1/2 (6)	3 (7)	4 (8)
CB, CF, CR (Screw Head Clearance Holes)	\$2.40 per end	\$2.50 per end	\$2.50 per end	\$2.50 per end	\$2.50 per end	\$2.50 per end	\$2.50 per end	\$2.50 per end
HB, HF, HR (Threaded Mounting Holes)	2.85 per end	2.95 per end	3.15 per end	3.95 per end	3.95 per end	4.60 per end	4.60 per end	5.65 per end
PM, SM (Pivot Mount)	10.95	11.55	13.40	18.20	21.15	27.25	32.75	44.75

Options No charge for Options P2 thru P8, TCF, TN	Adders by Bore Size							
	1/2 (1)	3/4 (2)	1-1/16 (3)	1-1/2 (4)	2 (5)	2-1/2 (6)	3 (7)	4 (8)
E (Magnetic Piston Sensing)	\$4.50	\$4.50	\$4.50	\$6.65	\$11.15	\$14.80	\$19.40	\$22.00
L (Low Friction Seals)	6.20	6.60	8.20	9.20	10.75	13.25	15.40	18.05
M, M1, M3, M4 (Mag. Piston Sensing)	5.95	5.95	5.95	8.75	14.75	22.05	26.55	29.30
Q (Low Temperature Seals)	4.60	5.80	7.30	9.15	11.45	14.35	17.90	22.45
Q (with Low Friction Seals)	9.95	12.50	15.60	19.70	24.65	30.85	38.55	48.25
TCM, TFM (Male Rod Thread)	3.85	4.00	4.45	4.80	6.80	6.80	8.05	9.60
T1, T3, T4 (Switch Mounting Rail per rail)	2.25	2.25	2.90	2.90	2.90	3.60	3.60	3.60
V (with Standard Seals)	4.70	5.05	7.40	11.75	15.75	21.30	31.15	39.00
V (with Low Friction Seals)	13.85	14.10	22.60	28.00	44.50	56.05	65.75	79.25
W (Rod Wiper)	6.65	7.05	8.60	9.20	10.80	11.45	13.15	13.90
X (each 1/2" or fraction thereof)	0.60	0.60	0.80	0.95	1.20	1.20	1.30	1.65

Sensor Prices

Electronic Sensor Type	Prewired Part No.	Price	Quick Disconnect Part No.	Price
Sourcing	949-000-031	\$23.80	949-000-331	\$31.30
Sinking	949-000-032	23.80	949-000-332	31.30

Female Cord Set	Part No.	Price
1 Meter	CFC-1M	\$14.35
2 Meters	CFC-2M	16.05
5 Meters	CFC-5M	20.30

Sensor Mounting Clamp for Standard, Twin Rod & 3-Position Series							Sensor Clamp for Multi-Power® Series	
Bore	1/2 (1)	3/4 (2)	1-1/16 (3)	1-1/2 (4) and 2 (5)	2-1/2 (6) and 3 (7)	4 (8)	Bore	2-1/2 (6), 3 (7) & 4 (8)
Kit Number	SC-1	SC-2	SC-3	SC-5	SC-7	SC-8	Kit Number	900-G00-000
Price	\$5.30	\$5.30	\$5.30	\$5.30	\$5.30	\$5.30	Price	\$5.30

Accessory Prices

Clevis Bracket		
Kit No.	Bore	Price
CB-3	1/2 (1)	\$16.20
	3/4 (2)	
	1-1/16 (3)	
CB-6	1-1/2 (4)	22.90
	2 (5)	
	2-1/2 (6)	
CB-8	3 (7)	28.95
	4 (8)	

Trunnion Bracket (Pair)		
Kit No.	Bore	Price
TB-2	3/4 (2)	\$9.00
TB-5	1-1/16 (3)	10.70
	1-1/2 (4)	
TB-7	2 (5)	12.80
	2-1/2 (6)	
TB-8	3 (7)	15.05
	4 (8)	

Rod Eye		
Kit No.	Bore	Price
RE-1	1/2 (1)	\$11.30
RE-2	3/4 (2)	12.00
RE-3	1-1/16 (3)	12.00
RE-4	1-1/2 (4)	12.55
RE-6	2 (5)	12.55
	2-1/2 (6)	
RE-7	3 (7)	14.05
RE-8	4 (8)	14.05

Seal Kits – Series PSD, PSR, PSX, PWD, PTD

Options	Kit Numbers and Prices by Bore Size							
	1/2"	3/4"	1-1/16"	1-1/2"	2"	2-1/2"	3"	4"
Standard	PS-1-SK \$3.15	PS-2-SK \$4.50	PS-3-SK \$3.95	PS-4-SK \$4.30	PS-5-SK \$4.60	PS-6-SK \$6.20	PS-7-SK \$6.85	PS-8-SK \$6.15
Viton (V)	PS-1-SKV \$6.00	PS-2-SKV \$7.80	PS-3-SKV \$8.15	PS-4-SKV \$10.55	PS-5-SKV \$14.45	PS-6-SKV \$22.35	PS-7-SKV \$27.50	PS-8-SKV \$31.55
Low Temperature (Q)	PS-1-SKQ \$4.60	PS-2-SKQ \$5.25	PS-3-SKQ \$5.25	PS-4-SKQ \$5.80	PS-5-SKQ \$6.45	PS-6-SKQ \$10.15	PS-7-SKQ \$12.05	PS-8-SKQ \$10.00
Low Friction (L)	PS-1-SKL \$4.30	PS-2-SKL \$4.80	PS-3-SKL \$8.35	PS-4-SKL \$9.00	PS-5-SKL \$9.35	PS-6-SKL \$11.45	PS-7-SKL \$13.30	PS-8-SKL \$14.00
Low Friction-Viton (L, V)	PS-1-SKLV \$15.75	PS-2-SKLV \$15.30	PS-3-SKLV \$25.35	PS-4-SKLV \$27.65	PS-5-SKLV \$24.75	PS-6-SKLV \$34.30	PS-7-SKLV \$37.95	PS-8-SKLV \$41.90
Low Friction-Low Temperature (L, Q)	PS-1-SKLQ \$6.65	PS-2-SKLQ \$6.95	PS-3-SKLQ \$8.15	PS-4-SKLQ \$8.75	PS-5-SKLQ \$10.15	PS-6-SKLQ \$14.10	PS-7-SKLQ \$17.35	PS-8-SKLQ \$15.75

Seal Kits – Nonrotating Series PND

Options	Kit Numbers and Prices by Bore Size			
	3/4"	1-1/16"	1-1/2"	2"
Standard	PN-2-SK \$4.05	PN-3-SK \$3.85	PN-4-SK \$4.15	PN-5-SK \$4.50
Viton (V)	PN-2-SKV \$7.00	PN-3-SKV \$7.15	PN-4-SKV \$9.65	PN-5-SKV \$13.55
Low Temperature (Q)	PN-2-SKQ \$4.60	PN-3-SKQ \$5.00	PN-4-SKQ \$5.65	PN-5-SKQ \$6.20

Seal Kits - Multi-Power® Series PA & PB

Options	Kit Numbers and Prices by Stages and Bore Size								
	PM2-2 1/2"	PM2-3"	PM2-4"	PM3-2 1/2"	PM3-3"	PM3-4"	PM4-2 1/2"	PM4-3"	PM4-4"
Standard	PM2-6-SK \$9.85	PM2-7-SK \$10.60	PM2-8-SK \$9.45	PM3-6-SK \$13.95	PM3-7-SK \$15.00	PM3-8-SK \$13.55	PM4-6-SK \$18.05	PM4-7-SK \$19.35	PM4-8-SK \$17.65
Viton (V)	PM2-6-SKV \$32.15	PM2-7-SKV \$38.55	PM2-8-SKV \$38.90	PM3-6-SKV \$44.95	PM3-7-SKV \$54.05	PM3-8-SKV \$55.20	PM4-6-SKV \$57.80	PM4-7-SKV \$69.55	PM4-8-SKV \$71.50
Low Temperature (Q)	PM2-6-SKQ \$15.85	PM2-7-SKQ \$18.25	PM2-8-SKQ \$15.05	PM3-6-SKQ \$24.55	PM3-7-SKQ \$25.45	PM3-8-SKQ \$21.35	PM4-6-SKQ \$28.60	PM4-7-SKQ \$32.75	PM4-8-SKQ \$27.65

Seal Kits - Multi-Position Series P3D

Options	Kit Numbers and Prices by Bore Size							
	1/2"	3/4"	1-1/16"	1-1/2"	2"	2-1/2"	3"	4"
Standard	P3-1-SK \$4.00	P3-2-SK \$5.80	P3-3-SK \$6.30	P3-4-SK \$6.90	P3-5-SK \$7.40	P3-6-SK \$9.85	P3-7-SK \$10.70	P3-8-SK \$9.60
Viton (V)	P3-1-SKV \$8.20	P3-2-SKV \$10.35	P3-3-SKV \$12.40	P3-4-SKV \$16.35	P3-5-SKV \$23.40	P3-6-SKV \$31.00	P3-7-SKV \$43.05	P3-8-SKV \$51.65
Low Temperature (Q)	P3-1-SKQ \$6.20	P3-2-SKQ \$6.80	P3-3-SKQ \$8.25	P3-4-SKQ \$9.20	P3-5-SKQ \$10.20	P3-6-SKQ \$15.85	P3-7-SKQ \$18.55	P3-8-SKQ \$15.75
Low Friction (L)	P3-1-SKL \$6.15	P3-2-SKL \$6.95	P3-3-SKL \$15.10	P3-4-SKL \$16.35	P3-5-SKL \$16.90	P3-6-SKL \$20.30	P3-7-SKL \$23.65	P3-8-SKL \$25.20
Low Friction-Viton (L, V)	P3-1-SKLV \$27.60	P3-2-SKLV \$26.40	P3-3-SKLV \$46.85	P3-4-SKLV \$50.60	P3-5-SKLV \$44.00	P3-6-SKLV \$59.40	P3-7-SKLV \$64.00	P3-8-SKLV \$72.35
Low Friction-Low Temperature (L, Q)	P3-1-SKLQ \$10.15	P3-2-SKLQ \$10.80	P3-3-SKLQ \$14.00	P3-4-SKLQ \$15.25	P3-5-SKLQ \$17.65	P3-6-SKLQ \$23.70	P3-7-SKLQ \$29.20	P3-8-SKLQ \$27.25



FABCO-AIR, Inc. ■ 3716 N.E. 49th Avenue ■ Gainesville, FL 32609-1699
 ■ Telephone (352) 373-3578 ■ Fax (352) 375-8024 ■ E-Mail service@fabco-air.com
 ■ Web Site <http://www.fabco-air.com>

Fabco-Air Product Catalog Library



Cylinders, Valves and Accessories
 Catalog #CV9

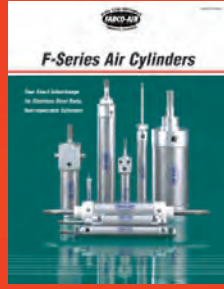

Stainless Steel Body Air Cylinders
 Catalog #SSB-03



Square Pancake® II Air Cylinders
 Catalog #SqPan2



ISO 6431 Cylinders
 Catalog #FAQR-09



Twin Rod, Non-Rotating Air Cylinders - Catalog # FDF-09 and Catalog # FDXS-09



Multi-Power® Air Presses
 Catalog #FP16

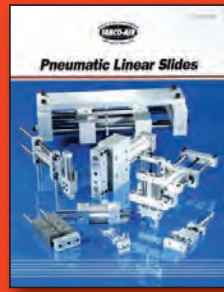

Linear Slides - 6 Families
 Catalog #LS-03

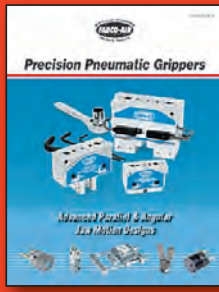

Pneumatic Grippers, Parallel Jaw and Angular Motion - Catalog # GR-8



Pneumatic Angular Grippers
 Catalog #FKA-09



ISO 6432 Cylinders
 Catalog #FAE-09



NFPA Interchangeable Air Cylinders - Catalog # NF-6

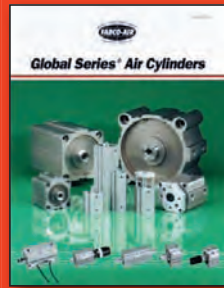

Global Series™ Metric Air Cylinders - Catalog # GC-15



Swing Clamps
 Catalog #SC-DB04

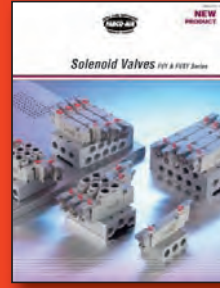

Manifold Solenoid Valves
 Catalog #FVS-Y-09

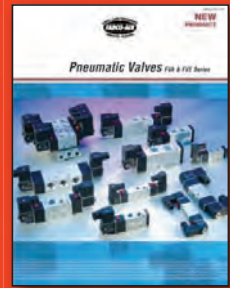

Air Pilot & Solenoid Valves
 Catalog #FVA.E-09



Modular Air Preparation System - FRLs
 Catalog #FRL-06

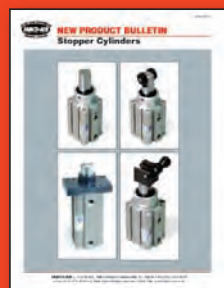

Stopper Cylinders
 Catalog #ST-SC



Swing Clamps, Pneumatic & Hydraulic
 Catalog #FML.H

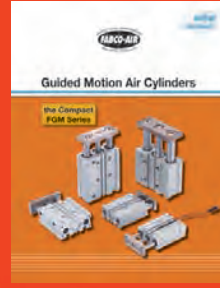

Guided Motion Air Cylinders
 Catalog #FGM-10



Air Slide Tables
 Catalog #FGXS-10