



Pneumatic Linear Slides



Product Index

Introduction–

Engineering considerations for product selection 4 -7
 Quick reference guide to Fabco-Air linear slides 8
 New attachment method
 for dovetail style sensors 9



GB750 with adjustable stop collars and bumpers

“GB” Series –

Construction & engineering data ... 10, 11
 Order guide 12
 Tooling and stop options 12
 Position sensing options 13
 Dimensions 14, 15

Model Size	Guide Shaft Dia.	Bore	Standard Stroke Lengths (Inch)
375	3/8"	12mm	1/2, 1, 1-1/2, 2, 3, 4, 5, 6, 7, 8, 9, 10
500	1/2"	20mm	1, 2, 3, 4, 5, 6, 7, 8, 9, 10
750	3/4"	32mm	1, 2, 3, 4, 5, 6, 7, 8, 9, 10



“L” series model shown with cushions



“S” series model shown with cushions

“L & S” Series –

Construction & engineering data ... 16, 17
 Order guide 18, 19
 “S” series dimensions 20
 “L” series dimensions 21
 Position sensing options 19
 Tooling and stop options 19, 22
 Cushions 23
 How to order summary 23

Model Size	Guide Shaft Dia.	Bore	Standard Stroke Length (Inch)
250	1/4"	5/16"	1/2", 1", 1-1/2", 2", 3", 4"
375	3/8"	9/16"	1/2", 1", 1-1/2", 2", 3", 4", 5", 6"
500	1/2"	3/4"	1", 2", 3", 4", 6", 8", 10", 12"
750	3/4"	1-1/16"	1", 2", 3", 4", 6", 8", 10", 12"
1000	1"	1-1/2"	1 to 4 by 1" incr., 6 to 24 by 2" incr.
1250	1-1/4"	2"	1 to 4 by 1" incr., 6 to 24 by 2" incr.
3-1250	1-1/4"	3"	1 to 4 by 1" incr., 6 to 24 by 2" incr.



“SE” series model shown with dowel hole/slot options on surfaces 2, 3 & 4

“SE” Series –

Construction & engineering data ... 24, 25
 Order guide 26-28
 Dimensions 30, 31
 Thin parts placer 25, 28, 29
 3-Position, tandem cylinder models 29
 Adjustable stop options 28, 35
 Dial-A-Stroke® option 36
 Position sensing options 27, 32, 33
 Stop and shock options 28, 34-36
 Hi-thrust (Multi-Power®) slides 35
 How to order summary 36, 37

Model Size	Guide Shaft Dia.	Bore	Standard Stroke Length (Inch)
250	1/4"	1/2"	1/2" to 4" by 1/2" increments
375	3/8"	3/4"	1" to 6" by 1" increments
500	1/2"	1-1/8"	1" to 10" by 1" increments
625	5/8"	1-1/8"	1" to 10" by 1" increments
750	3/4"	2"	1" to 6" by 1" increments 8" to 18" by 2" increments
1000	1"	2-1/2"	1" to 6" by 1" increments 8" to 20" by 2" increments
1500	1-1/2"	3-1/4"	2" to 30" by 2" increments



EZ625 with J72B electronic sensors

“EZ” Series –

Construction & engineering data ... 38, 39
 Order guide..... 40-45
 Dimensions..... 46-49
 Thin parts plater..... 49
 3-Position, tandem cyl. models 48
 Adjustable stop options 45
 Position sensing options 42, 43, 50, 51
 Tooling, stop and shock options 44, 45, 52-56
 Applications 57
 How to order summary 58, 59

Model Size	Guide Shaft Dia.	Bore	Standard Stroke Length (Inch)
250	1/4"	1/2"	1/2" to 4" by 1/2" increments
375	3/8"	3/4"	1" to 6" by 1" increments
500	1/2"	1-1/8"	1" to 10" by 1" increments
625	5/8"	1-1/8"	1" to 10" by 1" increments
750	3/4"	2"	1" to 6" by 1" increments 8" to 18" by 2" increments
1000	1"	2-1/2"	1" to 6" by 1" increments 8" to 20" by 2" increments
1500	1-1/2"	3-1/4"	2" to 30" by 2" increments

“EZP” Series – (pick & place)

Construction & engineering data
 EZP5025 60
 EZP7550 61
 Order guide..... 62-66
 Position sensing options 64, 65
 Tooling, stop & shock options 66, 67
 Dimensions
 EZP5025 68
 EZP7550 69
 3-position tandem cyl. models 70
 Toolbar / transition plates for parallel gripper mounting..... 71



EZP5025



EZP7550

“TS” Series –

Construction & engineering data ... 72, 73
 Order guide..... 74-76
 Dimensions..... 76-77
 Air cushion..... 72, 80
 Bolt-on options..... 78, 79
 Position sensing options 75, 79
 Rod scraper 74, 78, 80
 How to order summary 80, 81



TS200-3.0-MH3-TGSB-S03SB-H2R-H3L-RPB

Model Size	Bore	Guide Shaft Dia.	Standard Strokes in 1" Increments
112	1-1/8"	1/4"	1" to 10"
150	1-1/2"	3/8"	1" to 12"
200	2"	1/2"	1" to 15"
250	2-1/2"	5/8"	1" to 20"
325	3-1/4"	3/4"	1" to 20"
400	4"	1"	1" to 20"

Other Fabco-Air Linear Guided Motion Products

Global Series® Cylinders
 Guided Toolplate models
Catalog # GC-15



Pancake® Cylinders
 with External Guide Pins
 (Option “G”)
 See **Catalog # CV9**



Square 1® Cylinders
 with External Guide Pins
 (Option “G”)
 See **Catalog # CV9**



FABCO-AIR Linear Slides

Fabco-Air offers a wide assortment of linear slides, each suited to a vast variety of applications. But how does one know which slide to select? This section of the catalog will guide you through the selection process by providing useful information and helpful hints.

Selecting a linear slide involves five factors

Factor 1: Bore size of cylinder

(determines power factor and linear thrust)

Factor 2: Guide Shaft Diameter

(determines slide's load capacity)

Factor 3: Stroke (select from standard available strokes, or Fabco-Air can provide special stroke lengths)

Factor 4: Bearing Type and Guide Shaft material

(linear ball bearing or sleeve type bearing; guide shaft material is matched to bearing type and application environment)

Factor 5: Selection of slide series

(determines physical layout of the cylinder, bearings, guide shafts, toolbar/ toolplate)

Factors 1 through 3 – Bore, Guide Shaft Size & Stroke

In this catalog, each slide series is detailed in its own section. Engineering information can be found at the beginning of each section, detailing cylinder bore size, guide shaft size, and standard strokes, as well as loading information listing how much load can be supported at a given stroke and what amount of shaft deflection can be expected. Refer to this data to determine correct model size required for your application.

Factor 4 –

Bearings & Guide Shafts

Linear ball bearings vs. sleeve type bearings. . .

Linear ball bearings provide three major benefits:

1. Precision and accuracy - linear ball bearings can operate with little or no “play”, providing precise, repeatable motion.
2. Smooth, low friction motion - linear ball bearings can handle even severe overhung loads without sticking or binding. Rolling elements mean no sliding friction.
3. Long life - reduced friction provides long service life, especially on long strokes with high loads.

Sleeve type bearings – Duralon® or Rulon®

1. Sleeve bearings work best when used to support “carriage” type loads (where load is applied equally to the four bearings)
2. Sleeve bearings can handle moderate overhung loading. Heavy overhung loads can cause bearing to wear “egg-shaped”.
3. Sleeve bearings **must** have running clearance between I.D. and guide shaft. Therefore, some “play” will be exhibited at the toolbar. The closer the bearing-to-bearing spacing and/or the longer the stroke, the more free play motion at the toolbar.

Helpful bearing selection hints

- Long stroke, high speed applications are best handled by linear ball bearings.
- Short stroke, high cycle rate applications are best handled by Sleeve Type bearings. (example: 1" stroke @ 200 cycles per minute). Short, fast reciprocating motion can shorten the life of linear ball bearings and/or guide shafts because the inertia of the ball circuit causes “skidding” when direction is rapidly reversed.

– Engineering Considerations for Product Selection

Steel shell linear ball bearings – Yes!

Inexpensive linear ball bearings – No!

Fabco-Air linear ball bearing slides use high quality, high precision “steel shell” bearings that provide superior load support. Here's why. . With steel shell bearings, the bearing load is distributed back to the housing bore via the entire bearing O.D. The ball bearing's I.D. is unaffected by the housing bore size, therefore providing a very precise “fit” to the guide shaft. Bearing-to-shaft pre-load can be accurately established and maintained.

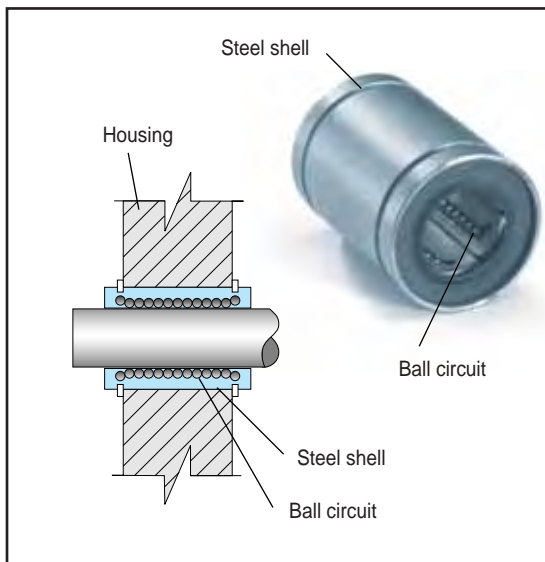

Competitor's slides, equipped with bearings with plastic housings and load-plate type ball circuit construction can be problematic.

This self aligning bearing concept is useful in applications where misalignment is likely. But it is unnecessary and often detrimental when used with packaged linear slides in which bearing housings are machined to such a high degree of accuracy.

Problem: bearing load is distributed back to the housing bore through small, crown shaped “bumps” on the load plates. High loads and/ or sudden impacts cannot be supported by such a small area, causing the crowns to deform the housing bore. Furthermore the **ball bearing's I.D. is DIRECTLY** affected by the housing bore size. Enlarged housing bores, whether caused by deformation or by improperly finished I.D.s will cause bearing “slop” and toolbar “play”.

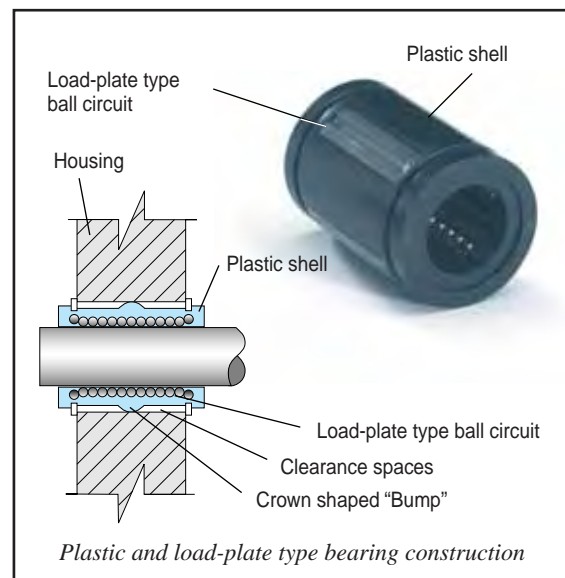

Conversely, bores that are too small, such as when closed up by over anodizing, will increase the pre-load to the shaft. Excessive pre-load causes bearing overload and premature bearing and/or shaft failure.

Some recently developed plastic housing linear ball bearings have a ring or band in the center to help support the load. This feature still does not have support equal to the steel shell bearings used on Fabco-Air slides, and because the ring is “split”, the bearing's I.D. is still directly affected by the final housing bore diameter.

FABCO-AIR Linear Slides

Factor 4 – continued

Linear Ball Bearing

Loading and Life Expectancy

Many slide applications involve an overhung load applied to the end of the guide shaft. In almost all of these cases, the slide's load capacity is determined by the strength of the guide shaft and its ability to resist bending. Linear ball bearings are **not** the limitation because their load capacities dramatically exceed the bending strength of the guide shafts.

Linear Ball Bearing Load Capacities

For Shaft Diameters of	Rolling Load Ratings
.250"	60 lbs each bearing
.375"	64 lbs each bearing
.500"	177 lbs each bearing
.625"	272 lbs each bearing
.750"	300 lbs each bearing
1.000"	410 lbs each bearing
1.500"	900 lbs each bearing

Example: from the load sizing guide found on page 45, a model EZ1000 slide with 2.0" stroke has a recommended overhung load of 200 pounds (produces .005" max. toolbar deflection or less). This load is supported by two linear bearings rated at 410 lbs each, 820 lbs total - which translates to a "safety factor" of more than 4 to 1! For a 20" stroke with the same .005" deflection, the load sizing guide gives a load recommendation of 4 pounds – a factor of over 200 to 1!

Linear ball bearings provide precise "no play" motion **and** long life is assured because it is loaded only to a small fraction of its capacity.

Life expectancy is 3 million to over 10 million cycles. This general cycle life can be predicted regardless of its stroke because the linear ball bearing is being so lightly loaded, compared to its rated capacity. Cycle life is determined as much by the number of "ball circuit reversals" as any other factor, including inches of total shaft travel.

Loading of Sleeve Bearings

Sleeve type bearings offer simplicity and low cost. They are ideal for moderate overhung loads, and can easily handle high loads in moderate speed carriage load applications.

Fabco-Air's superior Duralon® bearing offers increased performance over other sleeve bearing materials. Self lubricating, low friction Duralon® is a composite of Teflon®/Dacron® fabric liner bonded to filament-wound, high strength fiberglass and epoxy shell. Duralon® is resistant to corrosion, moisture, and temperature to 325° F. It has outstanding physical properties, very low friction, and will not gall or score guide shaft material.

Duralon® bearings are provided as standard on "GB" and "L & S" Series slides, and are available as an optional substitution (specify option code "X") on all other Fabco-Air linear slides. Rulon® bearings can be substituted for linear ball bearings by specifying option code "W". These bearings have an anodized aluminum shell with a Rulon® liner, and are available for users preferring this type of bearing material.

Guide Shaft Material Selection

The "GB" and "L & S" series slides are provided standard with pre-chrome plated stainless steel shafting. This material is supplied on other slides when option "X" (Duralon®) or option "W" (Rulon®) is specified. Slides with linear ball bearings are supplied with case hardened and ground steel (1045) shafting (shaft surface acts as inner race for the linear ball bearings). "SE" series uses a slightly larger tolerance material than "EZ" and "TS" slides, to provide a controlled pre-load for "no-play" motion. When option "Z", stainless steel shafting, is specified for use with linear ball bearings, a 440C case hardened and ground stainless material is supplied, ground to the same tolerance as 1045 shaft would be for that slide model.

Note: 1045 shafting is hardened to 60-65 Rc, while 440C stainless is hardened to 52-56 Rc. Higher loaded slides may have a slight shaft life expectancy reduction with the 440C material.

– Engineering Considerations for Product Selection

Moisture Environments – Application Tips

Coolant splash, water spray, and humidity applications can be handled by several methods. Duralon® and pre-chrome stainless steel shafting can be used. When linear ball bearings are used, Fabco-Air can supply units greased with a special moisture displacing lubricant and corrosion resistant plated guide shafts.

Operating Speed Considerations

An often overlooked aspect in the selection of linear slides is the speed at which it will operate. It can be difficult to obtain true and accurate speed information, yet ignoring speed factors can have disastrous results.

Safe speed range is generally 6 to 8 inches per second if no external stop options are utilized. A 12" stroke in 2 seconds is approximately 6"/second speed. It is approximate speed because we have not taken into account acceleration and deceleration time. On shorter strokes, ignoring acceleration/deceleration can be very misleading. A 1" stroke in 0.16 second is an average speed of 6"/second, but in reality, mid-stroke speed is much higher because a good portion of time was accelerating up to speed. It then requires a higher speed to travel that same distance in the 0.16 second time span. This higher speed develops severe impact forces when it suddenly stops at the end of stroke.

Machine cycle speed can also be misleading. Cycling at 30 parts per minute is a comfortable speed for moderate strokes. But, is the slide reciprocating at a uniform speed, or does it dwell (remain stationary) for part of the cycle? If so, the slide has to operate at a higher speed to make up for the time lost during dwell.

High speeds can be handled safely and reliably with the right combination of bearings/shaft, adjustable stops, and bumpers or hydraulic shock absorbers. Here are some tips:

Handling High Speeds

High speeds are best accomplished using linear ball bearings, as they can handle speeds up to 100 inches of travel per second. One exception is on short stroke (less than

1"), high cycle applications. Short, fast reciprocating motion tends to make the recirculating balls skid on the guide shaft when direction is reversed quickly, due to the inertia of the balls travelling in their track. A sleeve bearing may be superior in those applications. Fabco-Air offers both linear ball and sleeve bearings on most slide and pick & place models.

High speeds can cause heat buildup in the air cylinder caused by the friction of the seals. To minimize friction, most Fabco-Air slides are equipped with high quality, 80 durometer nitrile (Buna N) lip-type seals. Slides can be operated non-lubricated, but life expectancy is increased on high speed applications by using lubricated air.

High speed can cause damaging impact forces when the slide suddenly stops at the end of stroke. Adjustable stops should be used wherever possible to absorb impact externally rather than allowing the piston to bottom out inside the cylinder. "TS200" models and larger as well as "L & S 500" models and larger are available with air cushions to help decelerate the slide near end of stroke. Also, most slide models are available with either urethane bumpers or hydraulic shock absorbers. Urethane bumpers are an inexpensive way to absorb moderate impact forces while providing quieter operations. Precision end of stroke stop positioning is not possible though, as allowance must be made for the urethane to deform.

High loads at high speeds are best decelerated using hydraulic shock absorbers. Hydraulic shocks can be sized to the application, and provide a reliable way of decelerating a load over a given distance, bringing the motion to a safe, smooth stop in much the same way that a car is braked to a uniform stop (linear motion energy is converted to heat and dissipated). Hydraulic shocks are used in conjunction with adjustable stops. End of stroke stop positioning is precise (within .001") and pistons are not bottomed out in the cylinder. Linear energy remaining at the end of stroke after the hydraulic shock has decelerated the load is absorbed safely by the adjustable stop in the form of a minor impact force. With proper shock sizing, moderate to heavy loads can be operated at speeds up to 24 inches per second – and lighter loads even faster.

FABCO-AIR Linear Slides

Factor 5 – Quick Reference Guide to Slide Selection

Each Fabco-Air slide series is shown here for size and layout comparison.

For size comparison, drawings are to scale, showing 4" stroke slides with 1/2" diameter guide shafts.

"GB" Series (sleeve bearings)

Air cylinder is machined into bearing block. Standard features include bottom, side & rear mounting holes, top & side ports. Toolbar with top, front, and bottom mounting holes.

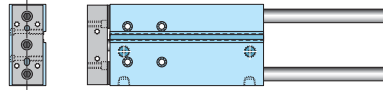

GB500-4

Reasons to select:

Rugged block slide, featuring replaceable Duralon® bearings, repairable built-in cylinder, interchangeable bolt pattern. Dual port locations, multiple mounting surfaces. Four inch stroke or less.

"L & S" Series (Sleeve bearings)

An inexpensive series using non-repairable air cylinders. The "L" Series is similar to the "EZ" Series while the "S" Series is similar to the "SE". Note: Sleeve bearings need clearance to operate. Therefore some toolbar play exists. "L" & "S" slides are not intended for ultra-precision applications.

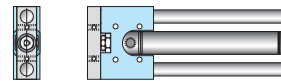

S500-4.0-MH1

Reasons to select:

Used for applications where the extreme precision of a linear ball bearing slide is not required.

"S" Series – Shorter than "L", but less capacity and more "play".

"L" Series – high load capacity. Less "play" than "S" because bearings are further apart.

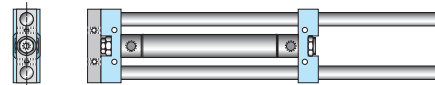

L500-4.0-MH1

"SE" Series (Linear ball bearings*)

A shortened version of the "EZ" Series to save length. Cylinder is built into the bearing block which houses four linear ball bearings.

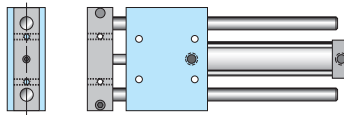

SE500-4.0-MS1

Reasons to select:

Shorter than "EZ". Good load capacity. Wide spacing of guide shafts to resist torsional load. Linear ball bearings at each end of bearing block provide "no-play" precision motion.

"EZ" Series (Linear ball bearings*)

Rugged slide with guide shafts either side of integral air cylinder. The bearings are spaced further apart as stroke increases, providing exceptional bearing support.

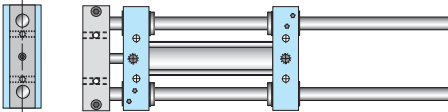

EZ500-4.0-MH1

Reasons to select:

Wide spacing of guide shafts to resist torsional load. Good load capacity. Provides "no-play" precision motion. Widest choice of tooling, stop, and shock options.

"TS" Series (Linear ball bearings*)

Very compact. It is the only linear ball bearing slide available that is "built into" the air cylinder.



TS200-4.0-MV2

Reasons to select:

Used where space is limited. High load capacity. Linear ball bearings at each end of cylinder provide "no-play" precision motion. Many tooling options available.

- Engineering Considerations for Product Selection

New Attachment Method for Dovetail Style Sensors

Introducing the universal sensor system

Now, one magnetically operated electronic sensor* can be used across the board on all pneumatic elements of your equipment design projects – on every cylinder, every linear slide, every gripper, and every press requirement.

This dovetail style sensor can be installed into integral dovetail slots on Fabco-Air Pancake® and Square 1® cylinder products, plus “GB” series slides and Global Series™ air cylinders equipped with magnetic pistons. The same sensor can be specified on Fabco-Air “SPG” series parallel grippers and the square or round body angular grippers.

By utilizing Fabco-Air's new and unique “double dovetail slot extruded aluminum rail”, shown in the photo (right), these same sensors can be used on “L & S”, “SE”, “EZ”, “EZP”, and “TS” series slide products by simply specifying a sensor option code in the catalog number. The extruded rail and dovetail sensors can also be purchased separately and installed on nearly any tube and tie-rod or “non-repair” type cylinder equipped with magnetic piston band.

How it works

An extruded aluminum rail with two side-by-side dovetail slots is attached to the cylinder body with a special adhesive-backed foam tape. The sensor inserts into one of the dovetail slots, is positioned as desired, and locked in place with a set screw.

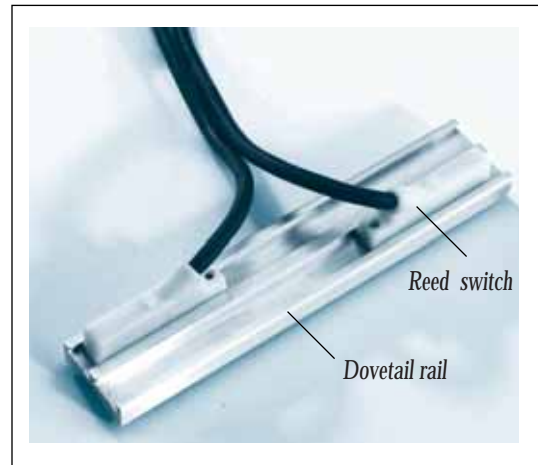

Double rail design allows side by side placement of the sensors to accommodate even the shortest stroke cylinders.

This compact and easy to install sensor mounting system is now available on the following Fabco-Air linear slide series: “L & S”, “SE”, “EZ”, “EZP” and “TS”.

*Note: Reed switch also available on most series.



Typical installation

The photo above shows an “SE” series linear slide with rail attachment and two sensors. Installation is quick and easy, and can be removed and remounted by simply peeling off and installing new tape. High-performance tape was originally developed for automotive trim parts, and provides a reliable attachment method with the convenience of “peel and stick” type tape.

Sensor adjustment is accomplished by simply sliding switch to



proper position and locking the set screw at the wire exit end of the switch (photo above right).

To order the rail separately. . .

Use catalog number “ER – (length in inches)”.

Example: ER-12.06 (overall length = 12 1/16”)

Rail is provided complete with adhesive foam tape.

To install, peel tape backing and apply to cylinder tube.

To order sensors for “ER” extruded rail, see page 13 of this catalog.

"GB" Series Linear Slides *Interchangeable, offe*

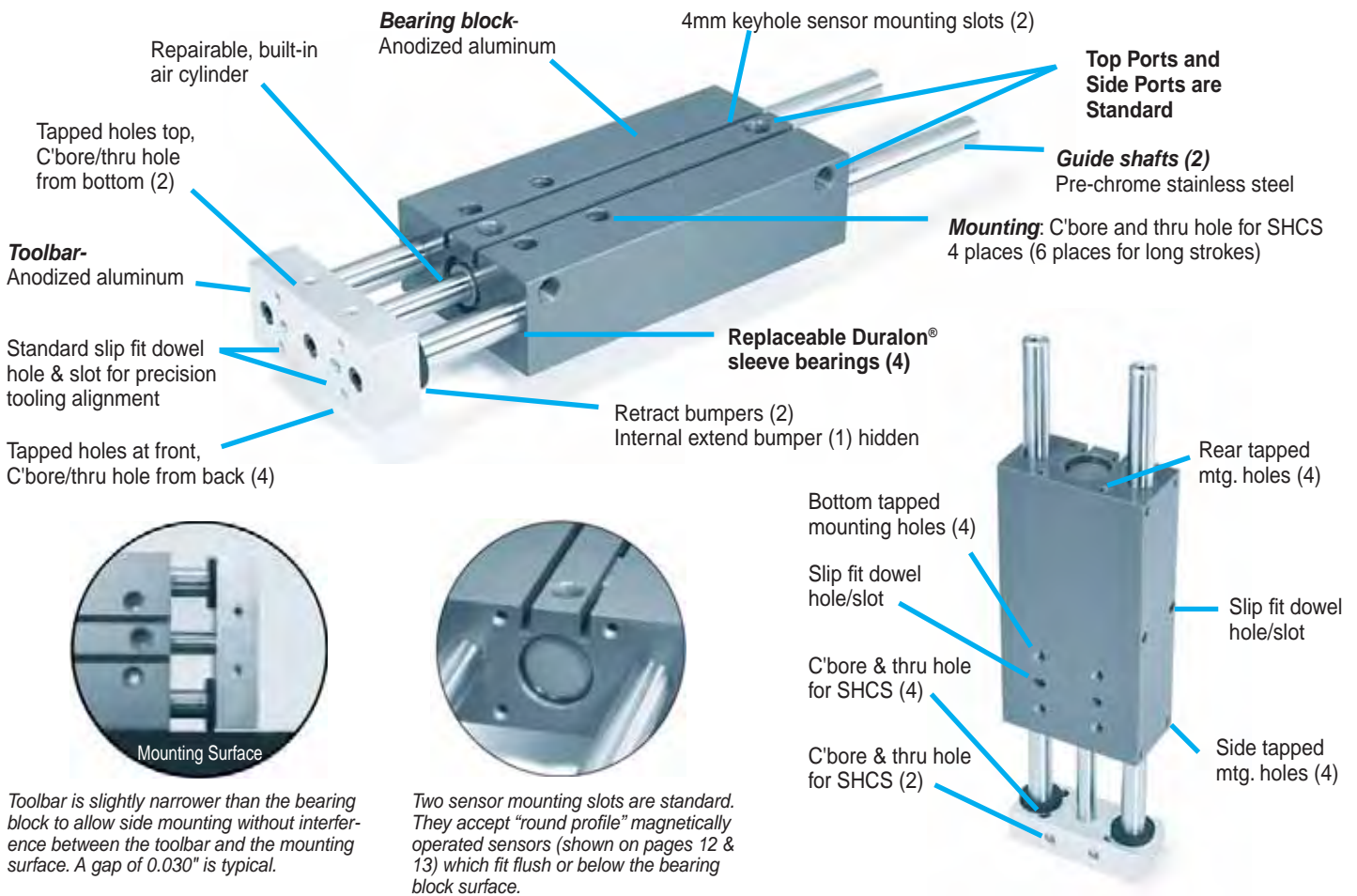

Toolbar is slightly narrower than the bearing block to allow side mounting without interference between the toolbar and the mounting surface. A gap of 0.030" is typical.

Two sensor mounting slots are standard. They accept "round profile" magnetically operated sensors (shown on pages 12 & 13) which fit flush or below the bearing block surface.

Check list of NEW Key Features of "GB" Series Block Style Slides

- Longer strokes:
 - GB375 - Now 1/2" thru 6" strokes
 - GB500 - Now 1" thru 10" strokes
 - GB750 - Now 1" thru 10" strokes
- Two 4mm keyhole sensor mounting slots
- New round profile sensors with advanced technical features

Check list of Standard Features

- Tapped/thru hole combination mounting holes top & bottom
- Tapped holes front face of toolbar (4)
- Anodized toolbar and bearing block
- Extend and retract bumpers
- Replaceable sleeve bearings
- Side tapped mounting holes in body
- Slip fit dowel holes/slots on bottom and side of body
- Toolbar is slightly narrower than body, allowing side mounting of slide with clearance between toolbar and mounting surface
- Slip fit dowel hole/slot on front face of toolbar
- Top and side ports

- Rear tapped holes in body - can be used for rear flange mounting
- Toolbar has square pattern front face tapped holes (4) that are also counterbored at back for thru bolt mounting
- Toolbar has vertical tapped/counterbored mounting holes

Check list of versatile Options Availability

- V - Viton seals allow operation to 325°F
- E - Magnetic piston for position sensing
- T1 - "Blank" toolbar
- A - Pair of clamp collars with rubber bumpers for extend adjustable stop
- B - Rear clampbar with rubber bumpers for extend adjustable stop (instead of collars)
- C - Tapped guide shafts at rear
- D - Rear stopbar, stop bolt and stop plate for adjustable extend stop
- F - Rear toolbar; same as front toolbar with matching hole pattern

Exceptional Guide Shaft Bearings - The better the bearing, the more cycle life you can expect from your slides.

Fabco-Air has incorporated a truly superior bearing material, Duralon®, for smooth performance and longer product life.

Duralon® is a composite of a Teflon®/Dacron® fabric liner bonded to a supporting filament-wound, high strength, fiberglass and epoxy resin shell. Resistant to corrosion, moisture and temperature to 325°F, the bearing is reliable in any environment. It has an extremely high load bearing capacity, very low friction, and will not gall or score the piston rod (see physical properties in the table below).

Duralon® Bearings Excel		Friction Properties	
Load Capacity (psi)		Coefficient	Slip-stick
Machine Design 1972/73 Bearing Reference Issue			
Porous Bronze.....	4,500	Steel-on-steel.....	.50 Yes
Porous iron.....	8,000	Bronze-on-steel.....	.35 Yes
Phenolics.....	6,000	Sintered Bronze-on-steel	
Nylon®.....	1,000	with mineral oil.....	.13 No
TFE.....	500	Bronze-on-steel	
Reinforced Teflon®.....	2,500	with mineral oil.....	.16 No
*TFE fabric.....	60,000	Copper lead alloy-on-steel	.22 Yes
Polycarbonate.....	1,000	Acetal-on-steel.....	.20 No
Acetal.....	1,000	Nylon-on-steel.....	.32 Yes
Carbon-graphite.....	600	Duralon-on-steel.....	.05 - .16 No

* Shows Duralon bearing classification. Not to be used for design purposes.

Printed with permission by Rexnord Corp. Duralon® is a registered trademark of Rexnord Corp.

ring longer strokes & more features than other block-style slides

Engineering Data

Model	GB375	GB500	GB750
Guide Shaft Diameter	3/8"	1/2"	3/4"
Bore	12 mm (.472")	20 mm (.787")	32 mm (1.260")
Power Factor Extend	.17	.49	1.25
Power Factor Retract	.13	.37	0.94

Pressure Rating: Maximum operating pressure is 150 psi Air

Output Force: Output Force = Pressure X Power Factor

Speed: Safe speed range is determined by a number of factors. The most important consideration is total reciprocating weight. High loads combined with high speeds can develop severe and damaging impact loads. For speeds over 10 inches per second use extend bumpers (Options "A" or "B").

Accuracy: GB Series Slides feature replaceable, high performance, self lubricating Duralon® sleeve bearings and special ground guide shafts. Straightness tolerance is .0015" per foot of guide shaft. Repeatability of extend stroke is .001" with Option "D".

Model Number	WEIGHT (lbs.)											
	Stroke (inches)											
	1/2	1	1-1/2	2	3	4	5	6	7	8	9	10
GB375	.58	.74	.88	1.03	1.32	1.61	1.90	2.19	-	-	-	-
GB500	-	1.78	-	2.36	2.96	3.55	4.14	4.74	5.33	5.93	6.52	7.12
GB750	-	3.83	-	4.96	6.11	7.23	8.36	9.50	10.63	11.76	12.90	14.02

Load Sizing Guide

GB Series

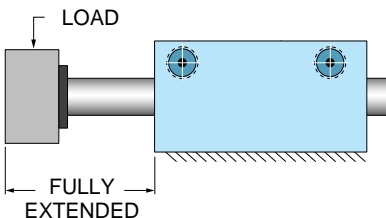

Load Limits: Safe loading involves a combination of factors including: bearing capacity, shaft strength and allowable deflection, life expectancy, how the load is applied, and how fast the load is accelerated/decelerated.

DO NOT OVERLOAD – Overloading can cause reduced product life, shaft bending and loss of position accuracy, as well as seal and bearing failure. **CAUTION:** Heavy reciprocating loads can cause damaging impact forces at end of stroke. It may be necessary to use stop collars and/or bumpers, or reduce speeds to avoid damage to slide and/or tooling.

Model Number	SAFE LOADS (lbs.)												Maximum Deflection
	Stroke (inches)												
	1/2	1	1-1/2	2	3	4	5	6	7	8	9	10	
GB375	6.0	6.0	6.0	6.0	6.0	3.5	3.0	2.5					.005"
	6.0	6.0	6.0	6.0	6.0	6.0	6.0	6.0					.015"
GB500		17.0		17.0	17.0	12.0	10.0	6.0	3.0	2.5	2.0	1.5	.005"
		17.0		17.0	17.0	17.0	16.0	12.0	8.0	6.0	4.0	2.5	.015"
GB750		42.0		42.0	42.0	42.0	34.0	26.0	18.0	10.0	7.0	4.0	.005"
		42.0		42.0	42.0	42.0	40.0	35.0	28.0	21.5	15.0	10.0	.015"

“GB” Series Linear Slides – Order Guide

Model Number Code

Series Model Size Stroke Options
GB 500 – 10.0 – AET1

Model Size	Guide Shaft Diameter	Bore	Power Factor		Standard Stroke Lengths (inches)
			Extend	Retract	
375	3/8"	12mm	.17	.13	1/2, 1, 1-1/2, 2, 3, 4, 5, 6
500	1/2"	20mm	.49	.37	1, 2, 3, 4, 5, 6, 7, 8, 9, 10
750	3/4"	32mm	1.25	0.94	1, 2, 3, 4, 5, 6, 7, 8, 9, 10

Helpful hints:

- **Model size = guide shaft diameters in three decimal places.**
- Force (pounds) at toolbar = (power factor) x (psi)
- Operating pressure range: 20 to 150 psi.

Option Descriptions

A – Pair of clamp collars with rubber bumpers for extend adjustable stop (Bumpers may be removed if not desired)



D – Rear stopbar, stop bolt and stop plate for adjustable extend stop (includes Option "C")



B – Rear clampbar with rubber bumpers for alternate extend adjustable stop (instead of collars) - bumpers may be removed if not desired



E – Magnetic piston for position sensing (Operating temperature range: -4°F to 176°F)

Order magnetic sensors separately. See page 13.



C – Tapped guide shafts at rear



F – Rear toolbar; same as front toolbar with matching hole pattern (will be blank if "T1" specified; includes Option "C")



T1 – "Blank" toolbar (no mounting holes) – No charge

V – Viton seals. Increases operating temperature limit to 325°F

Special Option: Proximity Switches – consult factory.

Magnetically Actuated Sensors – Use with Option “E”

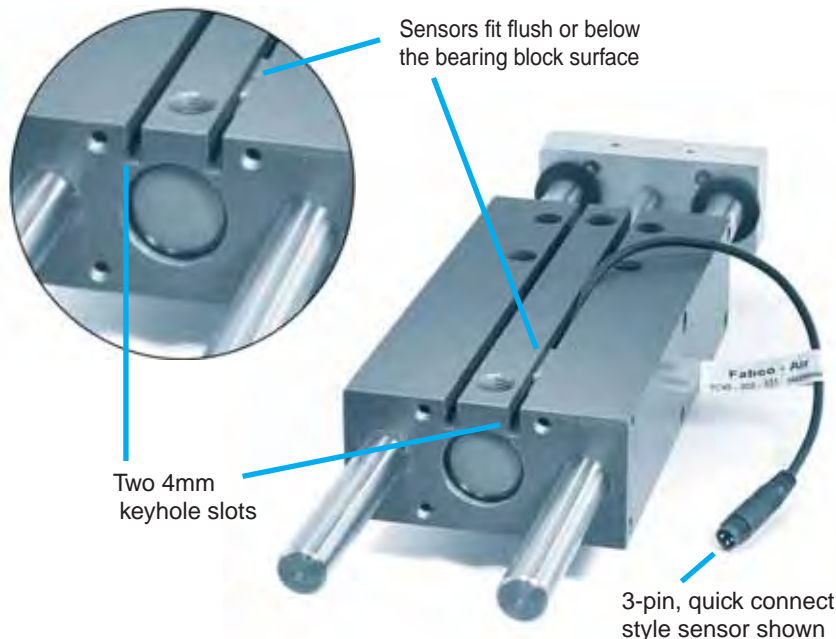

Round Profile Sensors feature surge suppression, polarity protection, LED indicator, and extremely fast switching speeds. They slide into mating 4mm keyhole slots on the top face of the bearing block and are easily positioned and locked in place with a set screw. They are offered in two styles: a quick connect style with a 6 inch pigtail and male connector, or a prewired style with a 9 foot lead.

Female Cordsets are available in 1, 2, and 5 meter lengths.

Specify Option E and order sensors and cordsets separately from the tables below.

Sensor Dimensions (mm unless noted)

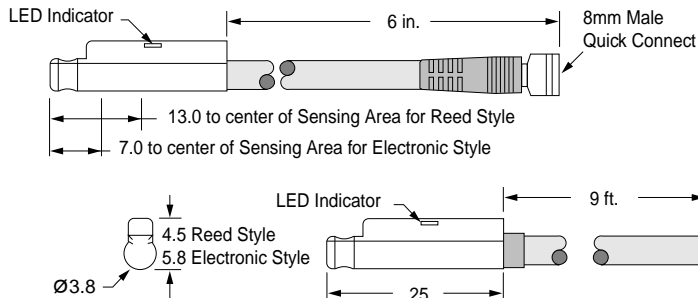

All sensors feature surge suppression, polarity protection, LED indicator, and extremely fast switching speeds.



Prewired sensor shown with 9 ft. lead



3 pin cordset shown with sensor pigtail

8mm Female Cordsets for Quick Connect Sensors

Cordset Description	Part No.
1 meter, 3-Pin	CFC-1M
2 meters, 3-Pin	CFC-2M
5 meters, 3-Pin	CFC-5M

Magnetic Sensors – Electrical Characteristics							Part Numbers	
Sensor Type	Function	Switching Voltage	Switching Current	Switching Power	Switching Speed	Voltage Drop	Prewired 9 ft. Part No.	Quick Connect Part No.
Reed Switch for PLC's w/LED (current limiting)	SPST Normally Open	5-120V AC/DC 50/60 Hz	0.04 Amp max 0.005 Amp min.	4 Watts max.	0.5 ms operate 0.1 ms release	2.5 Volts	9C49-000-002	9C49-000-302 Requires 3 pin cordset
Electronic LED and Sourcing	PNP Normally Open	6-30 VDC	0.2 Amp max.	6 Watts max.	1.5µs operate 0.5µs release	1.5 Volts	9C49-000-031	9C49-000-331 Requires 3 pin cordset
Electronic LED and Sinking	NPN Normally Open	6-30 VDC	0.2 Amp max.	6 Watts max.	1.5µs operate 0.5µs release	1.5 Volts	9C49-000-032	9C49-000-332 Requires 3 pin cordset

"GB" Series Linear Slides

Dimensions

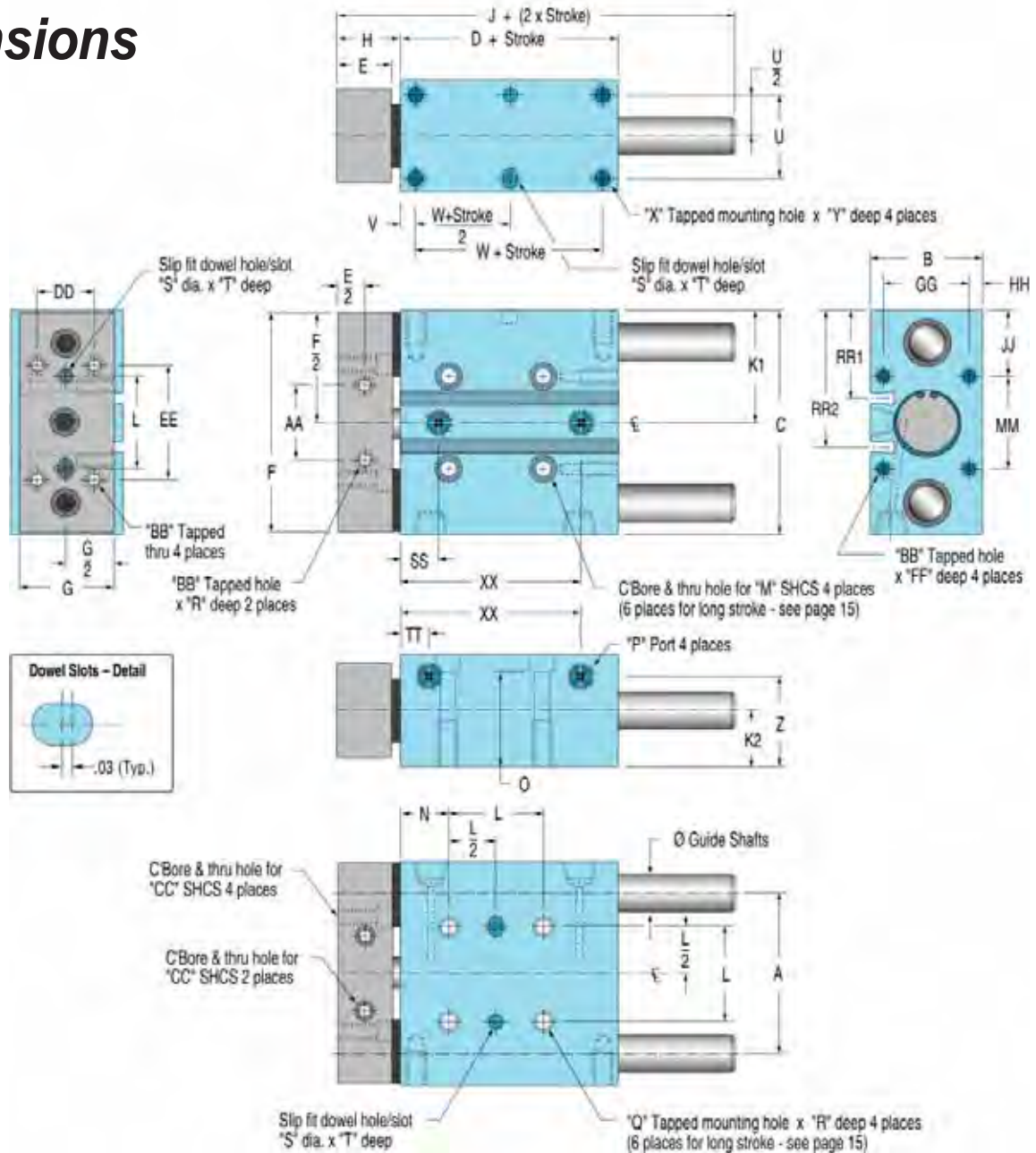

		"XX" Dimension (varies with stroke)											
		Stroke	1/2	1	1-1/2	2	3	4	5	6	7	8	9
Model 375		1.247	1.875	2.375	2.875	3.875	4.875	5.875	6.875	-	-	-	-
Model 500		-	2.375	-	3.375	4.375	5.375	6.375	7.375	8.375	9.375	10.375	11.375
Model 750		-	2.125	-	3.125	4.125	5.125	6.125	7.125	8.125	9.125	10.125	11.125

Slide Dimensions																					
Model	Bore mm	Bore Inch	Ø Guide Shaft Dia	A	B	C	D	E	F	G	H	J	K1	K2	L	M	N	O	P	Q	R
375	12	0.47	3/8"	1.625	1.00	2.25	1.375	.500	2.188	.812	.56	2.44	1.125	.500	.875	#6	.562	.79	10 - 32	10 - 24	.50
500	20	0.78	1/2"	2.125	1.50	3.00	1.875	.750	2.938	1.250	.88	3.31	1.500	.750	1.250	#10	.625	1.20	1/8 NPT	1/4-20	.63
750	32	1.26	3/4"	2.875	2.00	4.00	2.125	1.000	3.938	1.750	1.19	4.06	2.000	1.000	1.688	1/4"	.812	1.74	1/8 NPT	5/16-18	.88

Model	S	T	U	V	W	X	Y	Z	AA	BB	CC	DD	EE	FF	GG	HH	JJ	MM	RR1	RR2	SS	TT
375	1/8	.12	.750	.187	1.000	8 - 32	.38	.85	.625	6 - 32	#4	.500	1.000	.25	.625	.187	.688	.875	.92	1.34	.372	.372
500	3/16	.18	1.125	.187	1.500	10-24	.44	1.22	1.000	10-24	#6	.750	1.500	.50	1.125	.187	.875	1.250	1.17	1.83	.500	.375
750	1/4	.25	1.500	.250	1.625	1/4-20	.50	1.69	1.375	1/4-20	#10	1.000	2.000	.50	1.000	.500	1.156	1.688	1.58	2.43	.500	.500

Dimension Variations for longer stroke models

"LL" Dimension (varies with stroke)								
Stroke	3	4	5	6	7	8	9	10
Model 375	2.188	3.188	4.188	5.188	-	-	-	-
Model 500	-	-	4.000	5.000	6.000	7.000	8.000	9.000
Model 750	-	-	3.125	4.125	5.125	6.125	7.125	8.125

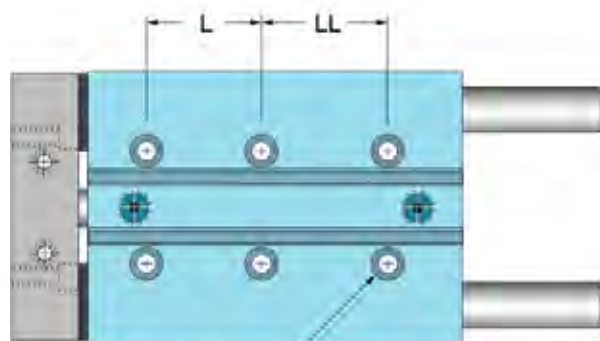

Hole for 'M' SHCS and 'Q' tapped hole 6 places

Option "A" Stop Collars

Model	A	B	C	D
375	.34	.88	.31	.06
500	.41	1.13	.44	.13
750	.50	1.50	.56	.19

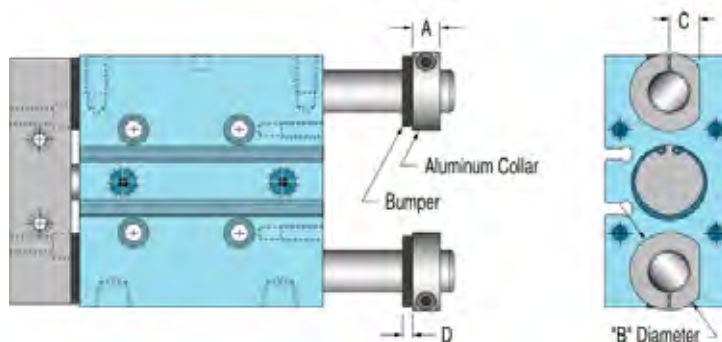

Option "B" Rear Clampbar

Model	A	B	C	D
375	.38	.75	.41	2.19
500	.50	1.25	.63	2.94
750	.50	1.75	.88	3.94

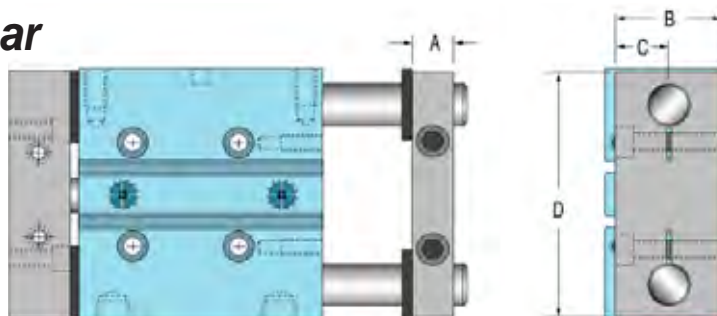

Option "C" Tapped Guide Shafts at Rear Option "D" Rear Stopbar, Stopbolt & Stop Plate

Model	A	B	C	D	E	F	G	H
375	8-32	.38	.25	.50	2.13	.13	10-24	1.25
500	10-32	.50	.31	.63	2.75	.13	1/4-20	1.59
750	5/16-24	.63	.38	.88	3.75	.13	5/16-18	1.31

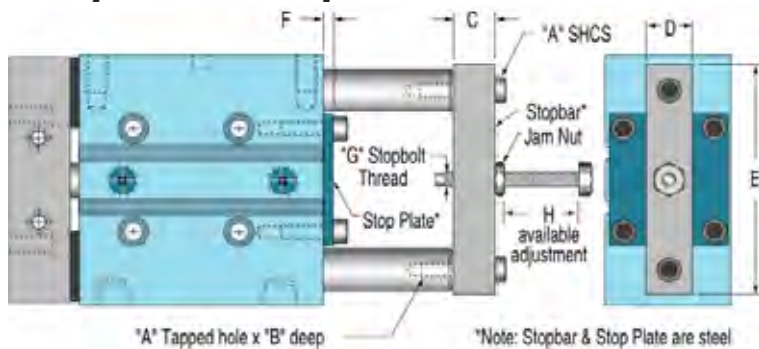

'A' Tapped hole x 'B' deep

*Note: Stopbar & Stop Plate are steel

"L" & "S" Series Linear Slides

Basic Model Selection

"S" Series (short) – single bearing block design, short overall length. (Photo this page)

"L" Series (long) – double bearing block design, increased bearing support. (Photo on next page)

Determine load capacity required and select a slide with appropriate guide shaft diameters and bearing block design.

Use the convenient sizing guide at the right to determine safe loading and shaft deflections for various stroke lengths.

"S" Series- pictured here

"L" Series- photo on next page

Pre-lubricated: All cylinders are factory lubricated with special high endurance oil.

Pre-Tested: The quality of each assembly is assured by testing each unit for leakage and binding resistance prior to shipment.

Front Toolbar
Clear anodized aluminum, machined top & front for squareness. Tapped mounting holes top & front are standard. Code – T1: Optional blank toolbar (no mounting holes)
Codes –T5 & T6: Optional toolbars for joining dissimilar slides together for X-Y motion.

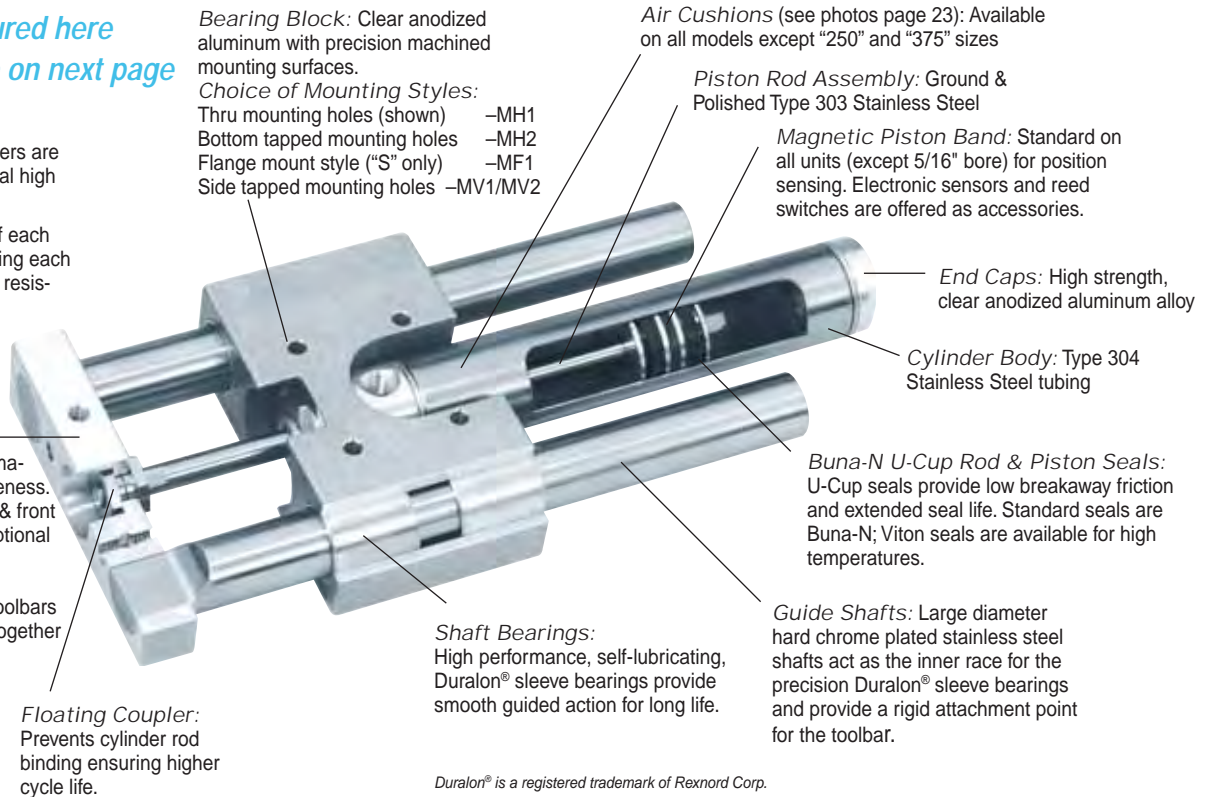

Floating Coupler: Prevents cylinder rod binding ensuring higher cycle life.

Duralon® is a registered trademark of Rexnord Corp.

Engineering Data

Model	S250	L250	S375	L375	S500	L500	S750	L750	S1000	L1000	S1250	L1250	S3-1250	L3-1250
Guide Shaft Diameter	1/4"		3/8"		1/2"		3/4"		1"		1-1/4"		1-1/4"	
Bore	5/16"		9/16"		3/4"		1-1/16"		1-1/2"		2"		3"	
Power Factor Extend	.07		.25		.44		.89		1.77		3.14		7.07	
Power Factor Retract	.06		.22		.39		.81		1.62		2.84		6.63	
Weight, lbs. @ zero stroke	.17	.19	.46	.57	1.00	1.22	1.89	2.38	6.04	6.33	10.16	11.47	18.15	17.97
Add per inch of stroke	.04	.07	.07	.13	.18	.25	.30	.54	.53	.96	.59	1.02	.71	1.14
Standard Strokes	1/2" to 2" by 1/2" 3" & 4"		1/2" to 2" by 1/2" 3" to 6" by 1"		1" to 4" by 1" 6" to 12" by 2"				1" to 4" by 1" 6" to 24" by 2"					

Pressure Rating: Maximum operating pressure is 150 psi Air

Output Force: Output Force = Pressure X Power Factor

Speed: Safe speed range is determined by a number of factors. The most important consideration is total reciprocating weight. High loads combined with high speeds can develop severe and damaging impact loads. For speeds over 10 inches per second use optional extend and retract bumper package and/or air cushions.

Accuracy: The toolbar rod coupler design allows clearance for piston rod float to protect against binding. At full extension, the toolbar will exhibit a small amount of axial end play. The actual toolbar travel may vary slightly from nominal as a result. In applications requiring extreme accuracy, adjustable stop collars should be used in conjunction with a longer stroke length to eliminate the effect of end play.

Running clearances are required between the sleeve bearings and guide shafts. The minimal resultant toolbar free play due to these running clearances is not included in the tabulated load limits (see table on next page).

Low cost, yet rugged, sleeve bearing type linear slides

Load Sizing Guide

S Series – Single Bearing Block (Short)

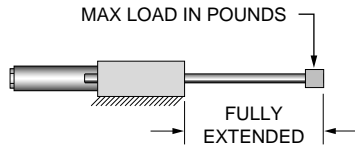

L Series – Double Bearing Block (Long)

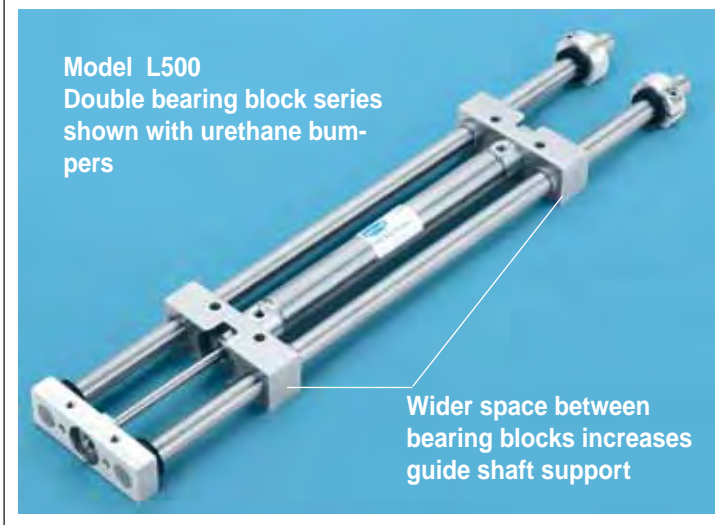
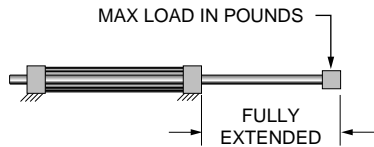

Load Limits: Safe loading involves a combination of factors including: bearing capacity, shaft strength and allowable deflection, life expectancy, how the load is applied, and how fast the load is accelerated/decelerated.

DO NOT OVERLOAD – overloading can cause reduced product life, shaft bending and loss of positional accuracy, as well as seal and bearing failure. **CAUTION:** Heavy reciprocating loads can cause damaging impact forces at end of stroke. It may be necessary to use stop collars and/or bumpers, or air cushions (except “250” and “375” model sizes), or reduce speeds to avoid damage to slide and/or tooling.

SAFE LOADS (lbs.)

Model Number	Stroke																Maximum Deflection
	1/2"	1"	1 1/2"	2"	3"	4"	6"	8"	10"	12"	14"	16"	18"	20"	22"	24"	
S250	3.7	3.7	3.0	2.1	1.5	1.0											.005"
	3.7	3.7	3.7	3.7	3.0	2.0											.015"
L250	5.0	5.0	4.0	2.5	1.7	1.2											.005"
	5.0	5.0	5.0	5.0	5.0	3.0											.015"
S375	7.5	7.5	7.5	7.5	4.8	2.5	1.5										.005"
	7.5	7.5	7.5	7.5	7.5	7.5	4.5										.015"
L375	10	10	10	10	6.0	3.5	2.5										.005"
	10	10	10	10	10	10	7.0										.015"
S500	18.7		18.7	14	5.8	2.5			1.2	0.8							.005"
	18.7		18.7	18.7	16	6.8	4.5	2.1	1.7								.015"
L500	25		22	15	7.0	3.0			1.5	1.0							.005"
	25		25	25	25	8.0	5.0	2.5	2.0								.015"
S750	30		30	20	13	5.0			2.5	2.0							.005"
	30		30	30	30	28	15	8.5	5.0								.015"
L750	40		40	35	23	10			4.0	2.5							.005"
	40		40	40	40	35	19	10	6.0								.015"
S1000	55		55	55	55	20			10	8.2	7.0	5.0	2.0	1.6	0.9	0.5	.005"
	55		55	55	55	55	50	35	18	12.0	7.5	5.0	4.5	2.8	0.9		.015"
L1000	70		70	70	70	32			16.4	12	10.5	8.0	5.4	3.1	1.4	0.7	.005"
	70		70	70	70	70	70	40	22	18.0	15.0	11.0	6.0	4.0	1.7		.015"
S1250	95		95	95	95	95	95	45	25	16.6	10.9	8.0	5.1	4.5	3.9		.005"
	95		95	95	95	95	95	95	95	54.0	39.0	22.7	17.5	13.0	8.5		.015"
L1250	125		125	125	125	125	125	70	39	26.0	17.0	12.5	8.0	7.0	5.5		.005"
	125		125	125	125	125	125	125	125	84.0	60.0	35.5	27.5	18.5	16.0		.015"
S3-1250	220		220	220	220	150	105	55	35	23.0	15.3	11.2	8.0	7.0	5.5		.005"
	220		220	220	220	220	220	150	122	74.0	55.0	31.8	27.5	18.5	16.0		.015"
L3-1250	280		280	280	280	256	130	70	39	26.0	17.0	12.5	8.0	7.0	5.5		.005"
	280		280	280	280	280	280	190	136	84.0	60.0	35.5	27.5	18.5	16.0		.015"

"L" & "S" Series Linear Slides – Order Guide

Step 1 Select a slide series ("L" or "S") of a size to meet loading considerations. Determine stroke length, mounting style, plus any optional toolbar, mounting bars or integral options (such as Viton seals).
Helpful hint: **Model size = guide shaft diameter in 3 decimal places.**

(L or S) 500 – 8.0 – MH1T1
Model Number Will End Here If No Options Are Desired
Leave Blank If No Integral Options Are Desired

Series
Model Size
Stroke
Mounting Style & Optional Toolbar
Integral Options

Model Size	Guide Shaft Diameter	Bore	Standard Stroke Length
250	1/4"	5/16"	1/2", 1", 1-1/2", 2", 3", 4"
375	3/8"	9/16"	1/2", 1", 1-1/2", 2", 3", 4", 5", 6"
500	1/2"	3/4"	1", 2", 3", 4", 6", 8", 10", 12"
750	3/4"	1-1/16"	1", 2", 3", 4", 6", 8", 10", 12"
1000	1"	1-1/2"	1 to 4 by 1" incr., 6 to 24 by 2" incr.
1250	1-1/4"	2"	1 to 4 by 1" incr., 6 to 24 by 2" incr.
3-1250	1-1/4"	3"	1 to 4 by 1" incr., 6 to 24 by 2" incr.

Integral Option Codes

- **V** Viton Cylinder Seals
- **P** In-line Top Ports ("S" Series only. . . Standard feature on S3-1250 Model only)
- **C** Air Cushions (500 size & larger) Details on pg. 23.

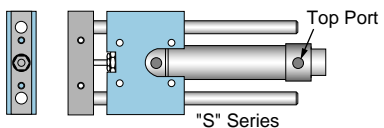

Toolbar Configurations

(For all mounting styles)
Optional toolbars, including blanks for machining custom mounting holes, may be substituted for standard toolbars at **no additional cost**.

All "L & S" Slides of the same model size can be joined together for 2-axis motion using the standard toolbars.

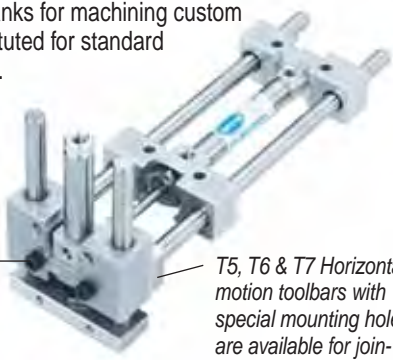

Allen Bolts attach this vertical unit with MH1 mounting to the toolbar of the horizontal unit.

T5, T6 & T7 Horizontal motion toolbars with special mounting holes are available for joining dissimilar "L" & "S" Series models.

Toolbar Option Codes

- **T1** = Blank Toolbar (no mounting holes).
- **T5** for L750 or S750
- **T6** for L1000 or S1000
- **T7** for L1250 or S1250 or L3-1250 or S3-1250

Horizontal Slide Vertical Slide

for L750 or S750 L500 or S500

for L1000 or S1000 L750 or S750

for L1250 or S1250 L1000 or S1000

or L3-1250 or S3-1250

To order: Add "Option Code" to Mounting Style.
Example: L750 – 10.0 – MH2T5

Note: When an "L" Series slide is to be used for the vertical motion, use MH1BP mounting style on the vertical slide. Both bearing blocks need to be attached to a mounting surface for stability.

Mounting Styles

- **MH1** Thru Mounting Holes (4)
 - "S" Series
 - "L" Series
- **MH1BP** ("L" Series Only) Package includes Base Mounting Plate attached to the MH1 bearing block
 - "L" Series
- **MH2** Tapped Mounting Holes (4 on opposite side)
 - "S" Series
 - "L" Series
- **MF1** Front Flange Mtg Holes ("S" Series Only)
 - Tapped Holes (4)
 - "S" Series
- **MV1** Side Tapped Mounting Holes (4)
 - "S" Series
 - "L" Series
- **MV2** Side Tapped w/Ports on opposite side
 - "S" Series
 - "L" Series

Optional "B1" Mounting Bars

For use with MV1 or MV2 mounting styles for both "L" & "S" Slides.

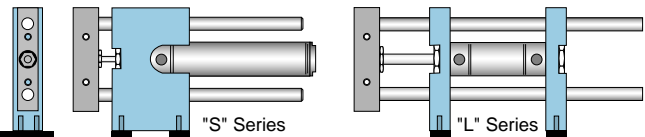

To Order: Add "B1" to mounting style. **Example: S375 – 4.0 – MV1B1**

Building the Model Number in 3 Easy Steps

Step 2 A magnetic piston band is standard on all units (except 250 models) for position sensing. Magnetically operated electronic sensors and reed switches are offered as accessories.

Step 3 What tooling will be required? Will stroke adjustability be needed?

Step 2: Sensing Options

— **J73B**
(4Digits)

Step 3: Tooling & Stop Options

— **RT — KE**

Sensor Codes (Use "S000" if NO Sensors are desired)

Select a code for sensor type and indicate position

Example: J73 **B** — {
E = Extend position only
R = Retract position only
B = Both extend & retract positions

Magnetically operated sensors are not available on "L" or "S" 250 Models.
Proximity Switches can be installed on any model as a special order. Consult factory.

Electronic Sensors & Magnetic Reed Switches

These sensors are actuated by a magnetic band that is standard on all "L" and "S" Series slides (except 250 Models) and are available in 2 mounting styles — **Clamp On** or **Dovetail** in pre-wired or quick disconnect versions.



"J" Style

"E" Style

Clamp-on style pre-wired and quick-disconnect sensors (Dual sensors require 2" or longer stroke).

Dovetail style pre-wired and quick-disconnect sensors are compatible with any stroke.

"J" Clamp-on Style Sensor Code

9 Ft. Prewired	Quick Disconnect*	Sensor Type	LED	Electrical Characteristics
J70 <input type="checkbox"/>	J71 <input type="checkbox"/>	Reed	Yes	5-120 VDC/VAC, 0.5 Amp Max, 10 Watt Max, SPST N.O., 3.5 Voltage Drop
J72 <input type="checkbox"/>	J73 <input type="checkbox"/>	Electronic	Yes	Sourcing PNP 6-24 VDC, 0.50 Amp Max, 1.0 Voltage Drop
J74 <input type="checkbox"/>	J75 <input type="checkbox"/>	Electronic	Yes	Sinking NPN 6-24 VDC, 0.50 Amp Max, 1.0 Voltage Drop

"E" Dovetail Style Sensor Code

9 Ft. Prewired	Quick Disconnect*	Sensor Type	LED	Electrical Characteristics
E70 <input type="checkbox"/>	E71 <input type="checkbox"/>	Reed	Yes	5-120 VDC/VAC, 0.03 Amp Max, 4 Watt Max, 2.0 Voltage Drop
E72 <input type="checkbox"/>	E73 <input type="checkbox"/>	Electronic	Yes	Sourcing PNP 6-24 VDC, 0.20 Amp Max, 0.5 Voltage Drop
E74 <input type="checkbox"/>	E75 <input type="checkbox"/>	Electronic	Yes	Sinking NPN 6-24 VDC, 0.20 Amp Max, 0.5 Voltage Drop
E76 <input type="checkbox"/>	E77 <input type="checkbox"/>	Reed	No	0-120 VDC/VAC, 0.5 Amp Max, 5 Watt Max, 0 Voltage Drop
E800	Dovetail Style Mounting Rail (Customer to furnish Sensors)			

* Order cordsets separately as follows:

Part No. **CFC-1M** is 1 meter cable with female connector.

Part No. **CFC-2M** is 2 meter cable with female connector.

Part No. **CFC-5M** is 5 meter cable with female connector.

— RT Rear Toolbar ("L" Series only)

Specifying **-T1** blank toolbar in "Step 1" also designates blank rear toolbar (**-RT**)

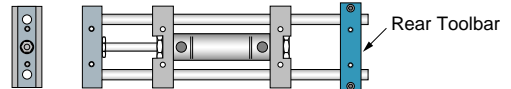

— PL Toolplate ("L" Series only)

Includes plate, stand offs, and the RT rear toolbar.

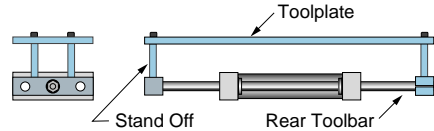

Options for either "L" or "S" Series

Stop Collars are used for stroke adjustment.

— **KE** = Stop Collars extend only

— **KR** = Stop Collars retract only

— **KB** = Stop Collars both extend and retract

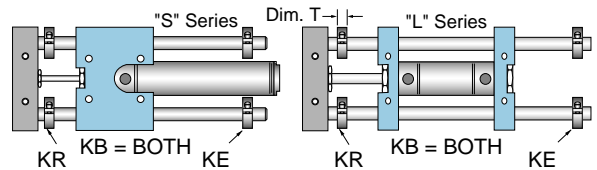

Use of "KR" reduces useable stroke length by thickness (Dim. "T") of collar. Use of "KE" in conjunction with "PL" or "RT" tooling option (on "L" Series only) reduces available stroke by thickness of collar.

Model	250	375	500	750	1000	1250	3-1250
Dimension "T"	.28	.34	.41	.50	.50	.50	.50

Urethane Bumpers —

— **UE** = Bumpers extend only and stop collars

— **UR** = Retract only, no stop collars

— **UB** = Bumpers both ends with stop collars extend

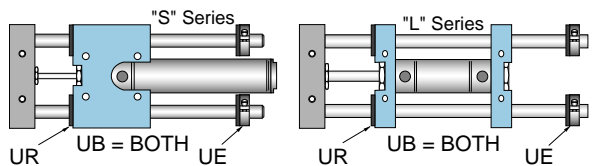

Note: With "PL" or "RT" tooling option ("L" Series only), the stop collar of the "UE" bumper option is deleted because the rear toolbar provides the bumper stop. For pricing, use the cost of a "UR" option in place of the "UE" option ("UE" option includes the cost of bumper washers and the stop collars).

Note: On models 750 & smaller, allow for a Urethane thickness of 1/8". On models 1000 & 1250, allow for a Urethane thickness of 1/4".

"L" & "S" Series Linear Slides

Series S (Short) – Single Bearing Block

Compact Single Bearing Block Design Provides Short Overall Length

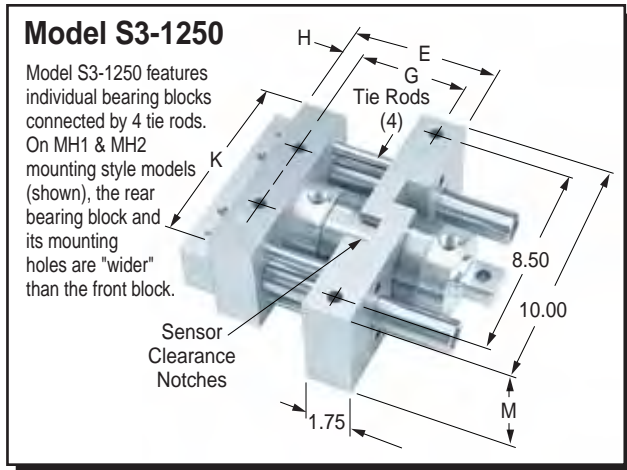

MH1 (Thru Hole) & MH2 (Tapped Hole) Mounting Styles

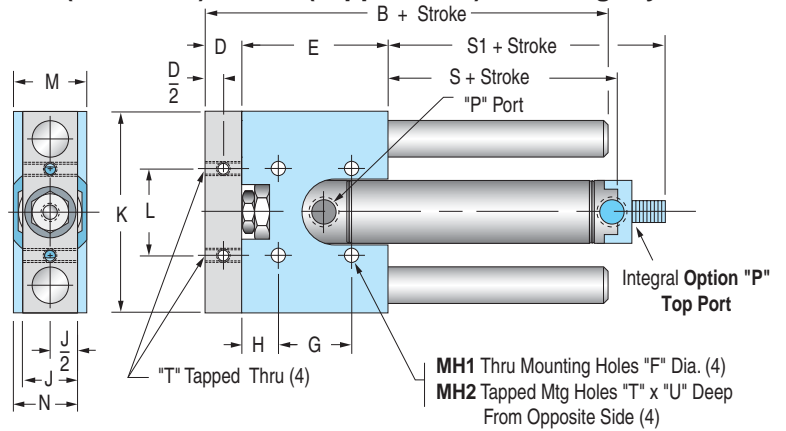

MV1 & MV2 Mounting Styles (Side Tapped Mtg. Holes)

MV1 Shown. MV2 has retract port on opposite side.

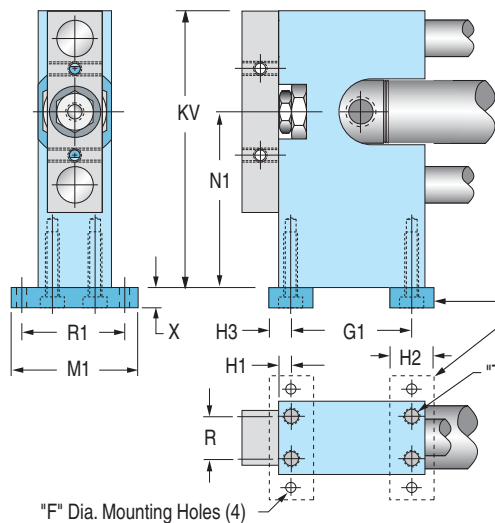

MF1 (Front Flange) Mounting Style

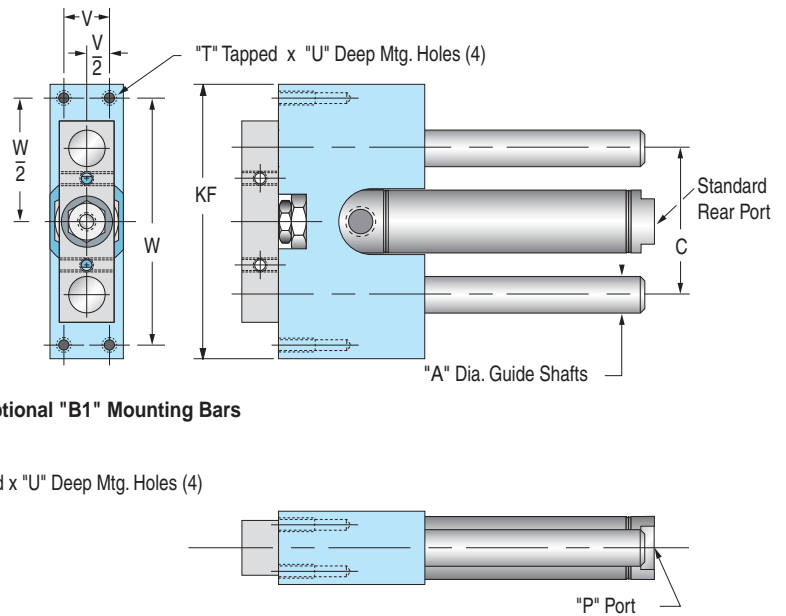

"S" Series Dimensional Data

Model	P Port	R	R1	S	S1	T	U	V	W	X
S250	#10-32	.312	.937	.77	1.31	#6-32	.25	.312	2.062	.25
S375	#10-32	.375	1.125	.86	1.40	#8-32	.38	.437	2.688	.25
S500	1/8 NPT	.562	1.500	1.63	2.20	#10-24	.50	.625	3.375	.38
S750	1/8 NPT	.750	1.875	1.37	1.75	1/4-20	.75	.750	4.625	.50
S1000	1/8 NPT	1.000	2.500	.20	1.02	3/8-16	.88	1.000	6.750	.63
S1250	1/4NPT	1.250	3.375	.75	2.13	1/2-13	1.00	1.250	9.000	.75
S3-1250	3/8 NPT	2.500	5.125	N/A	1.38	1/2-13	1.00	2.500	9.000	.75

Model	Bore	A	B	C	D	E	F	G	G1	H	H1	H2	H3	J	K	KF	KV	L	M	M1	N	N1
S250	5/16	1/4	2.25	1.312	.25	1.00	.144	.500	.688	.31	.16	.50	.25	0.56	1.75	2.38	2.38	.781	.63	1.25	.594	1.500
S375	9/16	3/8	2.37	1.625	.38	1.50	.177	.750	1.125	.44	.19	.62	.31	0.68	2.25	3.00	3.00	.937	.75	1.50	.718	1.875
S500	3/4	1/2	3.50	2.000	.50	2.00	.196	1.000	1.562	.50	.22	.75	.38	0.75	2.75	3.75	3.75	1.187	1.00	2.00	.875	2.375
S750	1-1/16	3/4	4.00	2.750	.62	2.50	.266	1.250	2.000	.63	.25	1.00	.50	1.00	3.88	5.13	5.13	1.500	1.25	2.50	1.125	3.188
S1000	1-1/2	1	5.75	4.000	1.00	3.75	.406	2.500	3.000	.63	.38	1.25	.63	1.50	5.50	7.50	7.50	2.250	1.75	3.25	1.625	4.750
S1250	2	1-1/4*	6.63	5.500	1.25	4.50	.531	3.000	3.000	.75	.75	1.75	.88	2.00	7.50	10.00	10.00	3.062	2.25	4.50	2.125	6.250
S3-1250	3	1-1/4*	8.13	5.500	1.25	6.00	.531	4.250	4.250	.88	.88	1.75	.88	2.00	7.50	10.00	10.00	3.062	4.00	6.25	3.000	6.250

*Note: S1250 & S3-1250 models feature hollow guide shafts (1/4" wall thickness) for dynamic weight savings

Mounting Style Dimensions

Series L (Long) – Double Bearing Block

Dual Bearing Blocks Provide Greater Stability and Increased Loading Capacity

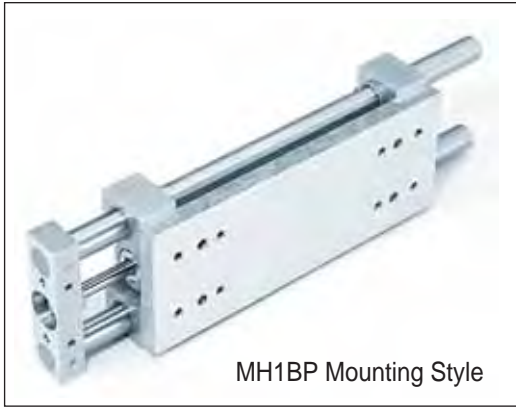

MH1BP Mounting Style

MH1 (Thru Hole) & MH2 (Tapped Hole) Mounting Styles

Does NOT Include Base Plate

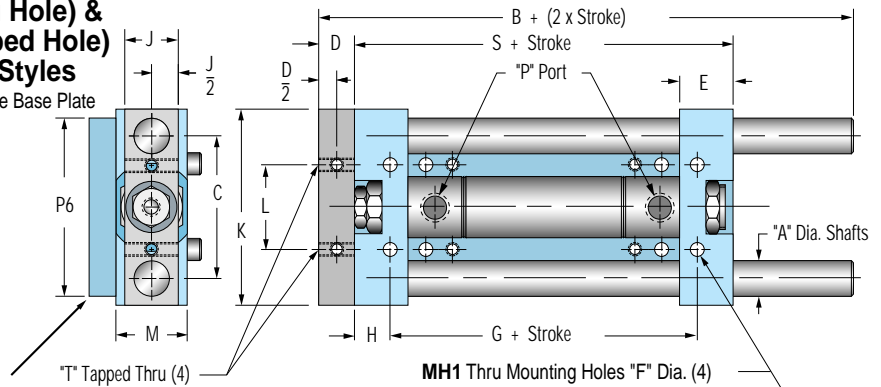

MH1BP Mounting Style (Includes Base Plate)

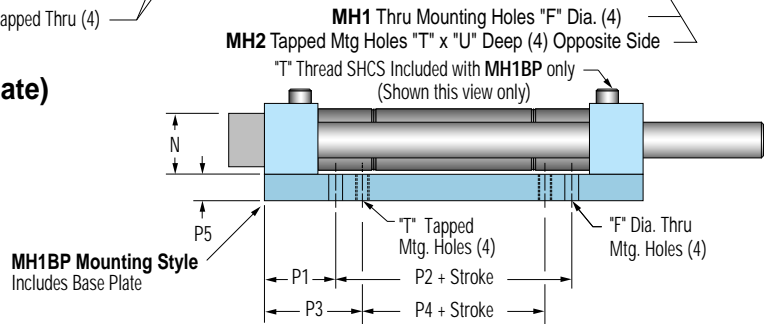

MV1 Mounting Style with B1 Mounting Bars

MV1 & MV2 Mounting Styles (Side Tapped Mtg. Holes)

MV1 Shown. MV2 has ports on opposite side.

"F" Diameter Mounting Holes (4)

Optional "B1" Mtg. Bars

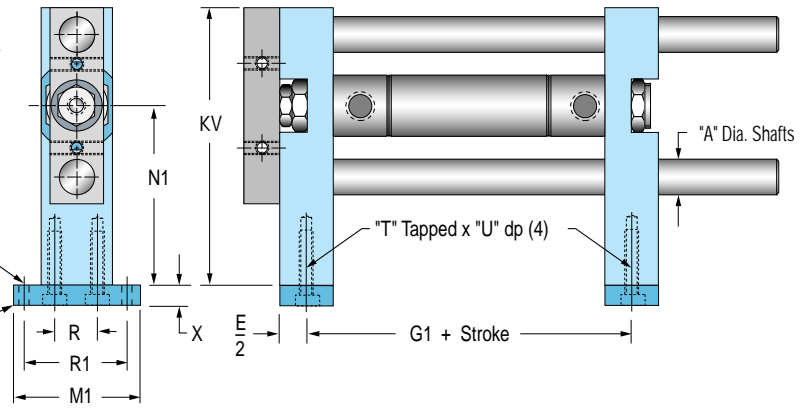

"L" Series Dimensional Data

Model	P3	P4	P5	P6	R	R1	S	T	U	X
L250	.94	.500	.25	1.25	.312	.937	2.38	#6-32	.31	.25
L375	1.25	.562	.25	2.00	.375	1.125	3.06	#8-32	.38	.25
L500	1.37	1.562	.38	2.50	.562	1.500	4.31	#10-24	.50	.38
L750	1.87	0.875	.50	3.00	.750	1.875	4.63	1/4-20	.75	.50
L1000	2.38	0.625	.75	4.00	1.000	2.500	5.38	3/8-16	.88	.63
L1250	2.93	1.500	1.00	5.00	1.250	3.375	7.36	1/2-13	1.00	.75
L3-1250	3.03	1.500	1.00	5.00	2.500	5.125	7.56	1/2-13	1.00	.75

Model	Bore	A	B	C	D	E	F	G	G1	H	J	K	KV	L	M	M1	N	N1	P Port	P1	P2
L250	5/16	1/4	3.25	1.312	.25	.50	.144	1.75	1.87	.31	.56	1.75	2.38	.781	.63	1.25	.594	1.500	#10-32	.69	1.000
L375	9/16	3/8	4.37	1.625	.38	.62	.177	2.18	2.44	.44	.68	2.25	3.00	.937	.75	1.50	.718	1.875	#10-32	.94	1.187
L500	3/4	1/2	5.50	2.000	.50	.75	.196	3.31	3.56	.50	.75	2.75	3.75	1.187	1.00	2.00	.875	2.375	1/8 NPT	1.00	2.312
L750	1-1/16	3/4	6.00	2.750	.62	1.00	.266	3.37	3.62	.63	1.00	3.88	5.13	1.500	1.25	2.50	1.125	3.188	1/8 NPT	1.38	1.875
L1000	1-1/2	1	7.75	4.000	1.00	1.25	.406	4.13	4.13	.63	1.50	5.50	7.50	2.250	1.75	3.25	1.625	4.750	1/8 NPT	1.63	2.125
L1250	2	1-1/4*	10.25	5.500	1.25	1.75	.531	5.86	5.61	.75	2.00	7.50	10.00	3.062	2.25	4.50	2.125	6.250	1/4 NPT	2.19	3.000
L3-1250	3	1-1/4*	10.50	5.500	1.25	1.75	.531	5.81	5.81	.88	2.00	7.50	10.00	3.062	4.00	6.25	3.000	6.250	3/8 NPT	2.28	3.000

*Note: L1250 & L3-1250 models feature hollow guide shafts (1/4" wall thickness) for dynamic weight savings

"L" & "S" Series Linear Slides

-RT Rear Toolbar Option ("L" Series Only)

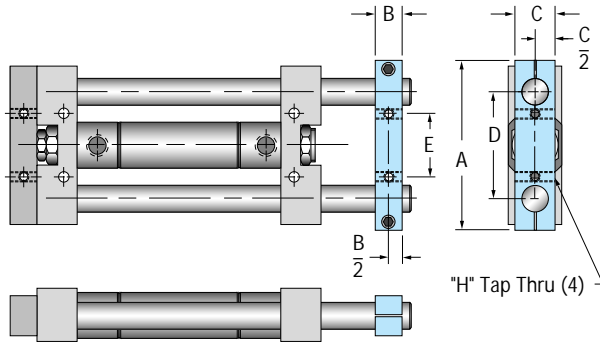

Note: If "T1" blank toolbar is specified for front, then rear toolbar will also be blank.

-PL Toolplate Option ("L" Series Only)

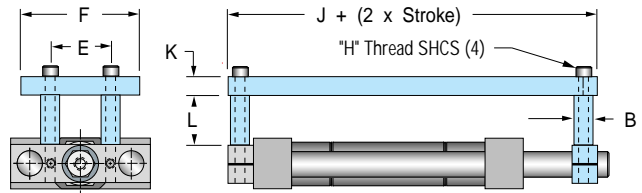

Low profile switch clamp with side-access clamp screw allows switch repositioning with toolplate in place.

Stop Collars: "- KE, -KR & -KB"

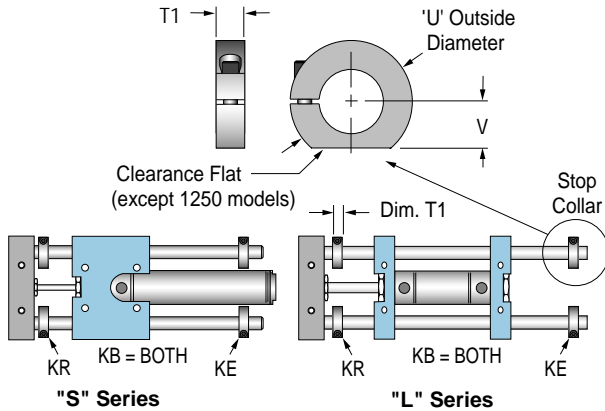

Urethane Bumpers: "- UE, -UR & -UB"

Note: Extend Bumper (-UE) includes Stop Collar as shown

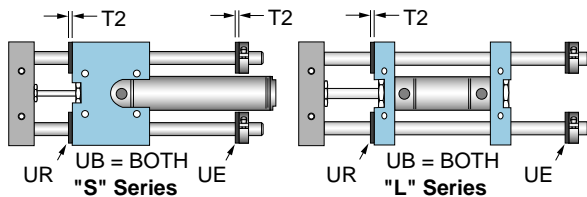

Optional Toolbars: "-T5, -T6 & -T7"

T5 is used on a 750 Model for attaching a 500 Model to create 2-axis motion.

T6 is used on a 1000 Model for attaching a 750 Model to create 2-axis motion.

T7 is used on a 1250 and 3-1250 Model for attaching a 1000 Model to create 2-axis motion.

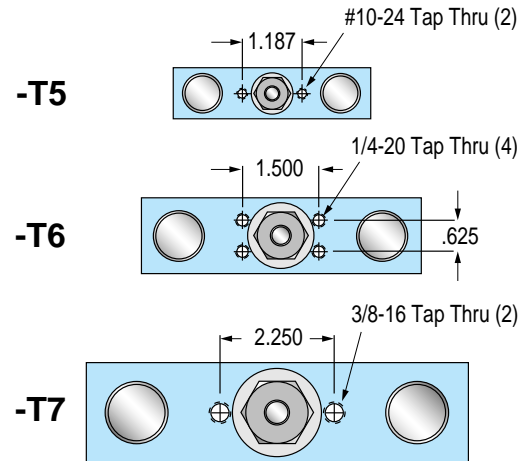

Tooling & Stop Options Dimensional Data

Model	Bore	A	B	C	D	E	F	H	J	K	L	T1	T2	U	V
L or S250	5/16	2.06	.25	.56	1.312	.781	1.25	#6-32	2.88	.25	1.03	.28	1/8	.63	.25
L or S375	9/16	2.56	.38	.69	1.625	.937	2.00	#8-32	3.81	.25	1.03	.34	1/8	.88	.31
L or S500	3/4	3.38	.50	.75	2.000	1.187	2.50	#10-24	5.31	.38	1.13	.41	1/8	1.13	.44
L or S750	1-1/16	4.63	.63	1.00	2.750	1.500	3.00	1/4-20	5.88	.50	1.13	.50	1/8	1.50	.56
L or S1000	1-1/2	6.25	1.00	1.50	4.000	2.250	4.00	3/8-16	7.38	.75	1.13	.50	1/4	1.75	.75
L or S1250	2	8.50	1.25	2.00	5.500	3.062	5.00	1/2-13	9.86	1.00	1.13	.50	1/4	2.06	N/A
L or S3-1250	3	8.50	1.25	2.00	5.500	3.062	5.00	1/2-13	10.06	1.00	2.00	.50	1/4	2.06	N/A

- Options & "How to Order" Summary

Cushions: Integral Option Code -C (Available on all "L & S" models except "250" and "375")

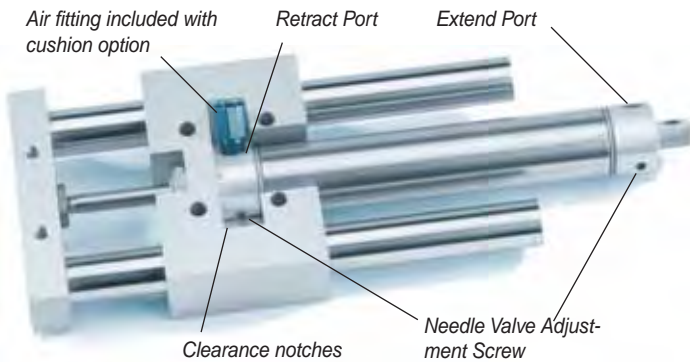

Cushions on an "S" Series slide

When cushion option is specified, the air cylinder is rotated in the bearing block(s) as shown in photographs. Ports are placed at an angle. Cushion needle valve is 90° to the port. The "S" bearing block is notched for port and needle valve clearance.

"S" model cylinders with cushions (S500 and larger) include in-line ports (Option "P").



Cushions on an "L" Series slide

How to Order Summary

Step 1

L500

- 6.0

- MH1BP

- V

Select "L" or "S" Series. Select model size based on guide shaft diameter

Select a stroke (Special strokes also available)

Choose Mounting Style & Toolbar

Select Integral Option

Step 2

- J72B

Sensor Options

Step 3

- PL - KE

Select Tooling & Stop Options

Model Size	Guide Shaft Diameter	Bore
250	1/4"	5/16"
375	3/8"	9/16"
500	1/2"	3/4"
750	3/4"	1-1/16"
1000	1"	1-1/2"
1250	1-1/4"	2"
3-1250	1-1/4"	3"

Model	Standard Stroke Length
250	1/2", 1", 1-1/2", 2", 3", 4"
375	1/2", 1", 1-1/2", 2", 3", 4", 5", 6"
500	1", 2", 3", 4", 6", 8", 10", 12"
750	1", 2", 3", 4", 6", 8", 10", 12"
1000	1 to 4 by 1" incr., 6 to 24 by 2" incr.
1250	1 to 4 by 1" incr., 6 to 24 by 2" incr.
3-1250	1 to 4 by 1" incr., 6 to 24 by 2" incr.

Tooling & Mounting Options

- MH1 Thru hole mounting
- MH1BP ("L" Series only) Base mounting plate attached to MH1 bearing blocks
- MH2 Tapped hole mounting
- MF1 Front flange mount ("S" Series only)
- MV1 Side tapped mounting holes
- MV2 Side tapped with ports on opposite side
- MV1B1 Side tapped mounting holes with base mounting bars
- MV2B1 Side tapped, ports on opposite side & base mounting bars

Toolbars

- T1 Blank Toolbar
- T5 Toolbar for Model 750 for attaching a Model 500
- T6 Toolbar for Model 1000 for attaching a Model 750
- T7 Toolbar for Model 1250 or 3-1250 for attaching a Model 1000

Cordsets w/Female Connector

- Order as separate items
- CFC-1M 1 meter cable
- CFC-2M 2 meter cable
- CFC-5M 5 meter cable

Integral Options

- V - Viton Seals
- P - In-line top ports ("S" Series only)
- C - Air cushions (Model "500" & larger)

Sensor Options

S000 indicates NO SENSORS desired

Note: Indicate sensor location in the box (). E= Extend, R=Retract, B=Both Extend & Retract

Band Clamp Style Sensor Options *

- J70 Reed Switch prewired
- J71 Reed w/quick disconnect
- J72 Electronic Sourcing, prewired
- J73 Electronic Sourcing, w/quick disconnect
- J74 Electronic Sinking, prewired
- J75 Electronic Sinking, w/quick disconnect

Caution: Dual Sensors require 2" or longer stroke

Dovetail Style Sensor Options *

- E70 Reed Switch prewired
- E71 Reed w/quick disconnect
- E72 Electronic Sourcing, prewired
- E73 Electronic Sourcing, w/quick disconnect
- E74 Electronic Sinking, prewired
- E75 Electronic Sinking, w/quick disconnect
- E76 Reed Switch prewired
- E77 Reed w/quick disconnect
- E800 Dovetail style mounting rail (Customer supplies the sensors)

Note:

- 1) Dovetail sensors compatible with all strokes
- 2) Proximity Switches are available as a special order. Consult factory.

Tooling Options

- RT Rear toolbar ("L" Series Only)
- PL Toolplate ("L" Series Only)

Stop Collars

- KE Extend only
- KR Retract only
- KB Extend & retract

Bumpers

- UE Extend only
- UR Retract only
- UB Extend & retract

* Not available on "250" models

"SE" Series Linear Slides *Ideal for applications*

Compact design – The SE Series Linear Slide was designed to fit precision motion applications where only limited space is available. The SE consists of a rugged, clear anodized, aluminum bearing block with **four, pre-loaded, sealed linear ball bearings** supporting hardened guide shafts and a front toolbar. (Optional sleeve-type, linear bearings are available. Code – X: Duralon®; Code –W: Rulon®) An integral air cylinder built into the rear of the bearing block powers the toolbar. The SE slide's compact design and precision construction make it ideal for many machine applications where slide loads are moderate and a minimum overall length is necessary.

Bearing Block
Clear anodized aluminum with precision machined mounting surfaces.

Thru-hole mounting (4) this side with tapped holes (4) on the opposite side.

Precision guide shafts
Straightness .0015" per foot. Standard case hardened (Rc 61 - 65) and ground (9 - 14 microinches RMS). **Optional stainless steel Code – Z.**

Optional Dowel Hole/Slot
Code –D ■■■■
Optional slip fit dowel holes and slip fit dowel slots allow for repeatedly precise slide mounting and/or attachment of end tooling. Option may be specified at any or all of the five surface locations shown in blue.

Dowel Surface 3

Dowel Surface 2

Front Toolbar

Clear anodized aluminum, machined top & front for squareness. Tapped mounting holes (top & front) are standard. Optional slip fit dowel holes and slip fit dowel slots assure repeatably precise tooling attachments.
Code – T1: Optional blank toolbar (no mtg holes)
Codes –T3 or T4: Optional toolbars for joining dissimilar slides together. SE and EZ Series can be combined for 2-axis motion.

Dowel Surface 4 this side Surface 5 Opposite Side

Stainless steel piston rod – End of piston rod is piloted into the back of the toolbar by a precision machined counter-bore. A socket head cap screw completes attachment to the toolbar. This design eliminates piston rod side loads, increasing cylinder seal life and improving performance.

Side tapped mounting holes in body (four on each side).

Bottom View – showing optional dowel holes and slots on surface 1, 2 & 4 (Dowel Code –D124)

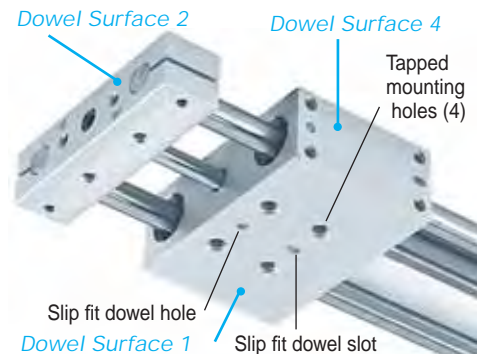

Engineering Data

Model	SE250	SE375	SE500	SE625	SE750	SE1000	SE1500
Guide Shaft Diameter	1/4"	3/8"	1/2"	5/8"	3/4"	1"	1-1/2"
Bore	1/2"	3/4"	1-1/8"	1-1/8"	2"	2-1/2"	3-1/4"
Power Factor Extend	.20	.44	.99	.99	3.14	4.91	8.30
Power Factor Retract	.17	.39	.88	.88	2.84	4.47	7.51
Weight, lbs. @ zero stroke	.41	.99	2.79	4.16	10.50	19.79	56.72
Weight per inch of stroke	.06	.13	.21	.27	.52	.81	1.60
Standard Strokes	1/2" to 4" by 1/2" increments	1" to 6" by 1" increments	1" to 10" by 1" increments	1" to 10" by 1" increments	1" to 6" by 1" increments; 8" to 18" by 2" increments	1" to 6" by 1" increments; 8" to 20" by 2" increments	2" to 30" by 2" increments

Pressure Rating: Maximum operating pressure is 150 psi

Output Force: Output Force in Pounds = Pressure X Power Factor

Speed: Safe speed range is 6 to 8 inches per second. Speeds from 8 to 20 inches per second are obtainable with the hydraulic shock absorber or urethane bumper option. For higher speeds, and/or heavy reciprocating load applications, consult factory.

Accuracy: SE Series Slides feature pre-loaded linear ball bearings for play-free operation. Each bearing has .0001"/.0003" pre-load built in with special ground guide shafts. The built-in air cylinder will stroke +.015"/-.000" of nominal stroke. Repeatability of stroke is ±.001". Straightness tolerance is .0015" per foot of shaft.

with moderate side loads & minimum overall length requirements

The Flexibility of Creating Custom 2-Axis Motion –

All like model SE Series slides (except the SE500) can be joined together to create a 2-axis motion device using standard toolbars. The bearing block of the vertical slide is easily bolted to the toolbar of the horizontal slide because the bolt hole patterns in the bearing blocks and the toolbars are identical. A no-cost, optional toolbar (T3) is available for joining two SE500s.

Because all SE Series slides (except the SE250) share identical toolbars with their “EZ” Series cousins, an “SE” slide is also easily combined with an “EZ” unit. Optional, no-cost toolbars (T3 & T4) are available for mixing and matching dissimilar “SE” and “EZ” models. (See Toolbar Configurations in the order guide).

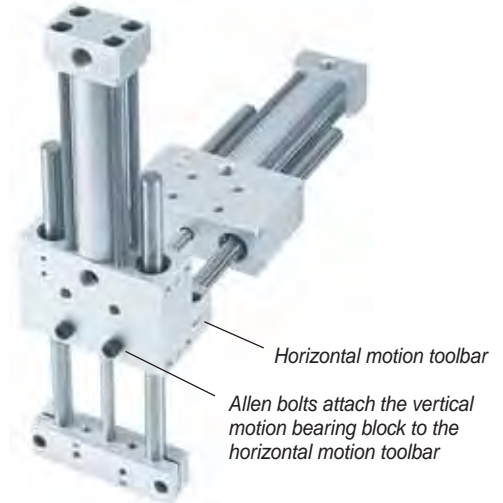
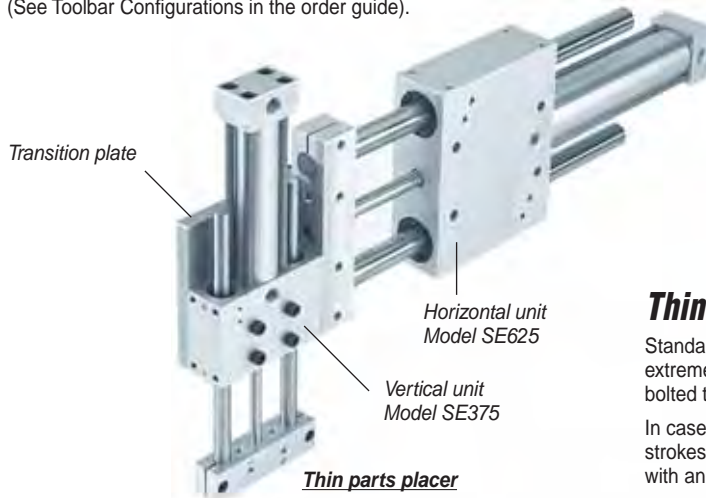

Two Model SE375 slides shown joined together

Thin Parts Placer –

Standard transition plates are available for joining two SE Series slides to create extremely compact 2-axis motion devices. The bearing block of the vertical unit is bolted to the transition plate which is mounted to the toolbar of the horizontal unit.

In cases where wider bearing separation is required on the horizontal unit (for longer strokes, heavier overhung loading, etc.), an EZ Series slide may also be combined with an SE Model.

Load Sizing Guide

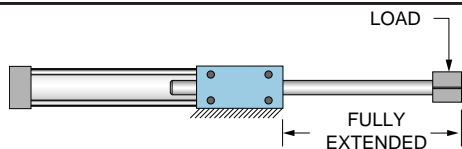

Chart indicates safe loading with standard linear ball bearings

Safe loading involves a combination of factors including: bearing capacity, shaft strength and allowable deflection, life expectancy, how the load is applied, and how fast the load is accelerated/decelerated. – **DO NOT OVERLOAD** – Overloading can cause reduced product life, shaft bending and loss of positional accuracy, as well as bearing and seal failure. **CAUTION:** Heavy reciprocating loads can create damaging impact forces at end of stroke. It may be necessary to use stop collars, bumpers, or hydraulic shock absorbers – or reduce speeds.

Model Number	SAFE LOADS (lbs.)															Maximum Deflection
	Stroke															
	1"	2"	3"	4"	5"	6"	7"	8"	9"	10"	12"	14"	16"	18"	20"	
SE250	4.0	2.4	1.8	1.3												.005"
	17	10	4.0	2.5												.015"
SE375	28	28	12	6.0	4.0	2.8										.005"
	28	28	28	18	12	6.8										.015"
SE500	84	44	24	12	8.0	6.0	4.0	3.0	1.8	1.4						.005"
	120	120	60	36	24	16	12	8.2	6.0	4.8						.015"
	120	120	110	70	50	32	22	16	12	9.6						.030"
SE625	150	84	44	28	16	12	9.0	7.8	5.6	4.0						.005"
	150	150	124	76	56	34	26	20	16	11						.015"
	150	150	150	140	88	60	56	38	29	22						.030"
SE750		100		56		20		12		8.0	5.0	4.0	2.2	1.8		.005"
		280		114		56		36		26	12	9.0	6.4	5.8		.015"
		300		200		96		40		40	30	19	17.2	12		.030"
SE1000		200		80		44		36		24	12	8.0	6.0	5.0	4.0	.005"
		470		220		120		80		50	36	24	17	13	12	.015"
		470		470		270		130		96	60	46	38	32	30	.030"
SE1500				Stroke	4"	6"	8"	10"	12"				18"	24"	30"	
					600	510	300	200	125				76	50	10	.005"
					800	600	385	340	300				124	70	30	.015"
					800	800	650	600	550				202	104	40	.030"

"SE" Series Linear Slides – Order Guide

Step 1 Select a slide model size, stroke length, mounting style, plus any optional toolbar, attachment (B1), or integral options (such as Viton seals). Helpful hint: **The model size = guide shaft diameter in 3 decimal places.**

Step 1: Basic Slide Model

SE500 – 5.0 (— Optional Tandem Cylinder Stroke) – MS1T1 — VZ

Series Model Size Stroke Mounting Style & Optional Toolbars Integral Options

Model Number Will End Here If No Options Are Desired

Leave Blank If No Integral Options Are Desired

Model Size	Guide Shaft Diameter	Bore	Standard Stroke Length
250	1/4"	1/2"	1/2" to 4" by 1/2" increments
375	3/8"	3/4"	1" to 6" by 1" increments
500	1/2"	1-1/8"	1" to 10" by 1" increments
625	5/8"	1-1/8"	1" to 10" by 1" increments
750	3/4"	2"	1" to 6" by 1" increments 8" to 18" by 2" increments
1000	1"	2-1/2"	1" to 6" by 1" increments 8" to 20" by 2" increments
1500	1-1/2"	3-1/4"	2" to 30" by 2" increments

3-Position Tandem Cylinder Slides

(Not available on SE250 or SE375)

Note: See pages 28 & 29 for principle of operation

Ordering example: SE750 – 5.0 – 2.0 – MS1 – J72M

Primary Cylinder Stroke Secondary Cylinder Stroke

Sensor locations – use "M" in the Box () if mid-position sensor is required (3 sensors). Note: "M" (mid-position) is not available with "S50, S51, S60" sensors. All sensors are located on the primary cylinder, which also contains the magnetic piston band for "E" & "J" options. Shock options "D, E & F" are not available on tandem units.

– MS1 Standard Mounting

Includes:

- Tapped mounting holes
- Thru mounting holes
- Side tapped mounting holes

– MS1B1 Optional Base Mounting Bars

Toolbar Configurations

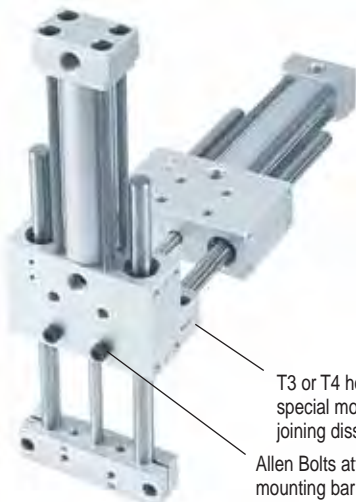

Optional toolbars T1, T3, & T4 may be substituted for standard toolbars at no additional cost.

All like models of SE Slides (except SE500) can be joined together for 2-axis motion using the standard toolbars. Use Option T3 to join two SE500 models.

All "SE" Slides (except SE250) share identical toolbars with their "EZ" Series cousins. Thus an "SE" slide is easily combined with an "EZ" slide for 2-axis motion.

T3 or T4 horizontal motion toolbar with special mounting holes is available for joining dissimilar models.

Allen Bolts attach the vertical motion unit to the mounting bar of the horizontal motion unit.

Toolbar Option Codes

– T1 = Blank Toolbar (no mounting holes).

For joining dissimilar models, specify the horizontal toolbar.

	Horizontal Slide	Vertical Slide
– T3	for SE500	SE500 or EZ500
– T4	for SE1000	SE500, EZ500, SE750, or EZ750

To order: Add "Option Code" to Mounting Style.

Example: SE1000 – 10.0 – MS1T4

Integral Option Codes

D – Dowel Hole/Slot Code & Location(s)
Available on any or all of the 5 mounting surfaces shown in blue on page 30.

Example: D13 specifies dowel hole/slot on bottom surface of bearing block (Surface #1) and on top surface of toolbar (Surface #3).

H – Hydraulic Cylinder Seals (150 psi max.)
V – Viton Cylinder Seals

Bearing Options

Sleeve bearings can be substituted for standard linear ball bearings.

W – Rulon® Shaft Bearings
X – Duralon® Shaft Bearings

Guide Shaft Options

Y – Hollow Guide Shafts
Case hardened & ground #52100 tubular steel available on SE750 Models and larger.

Z – Stainless Steel Guide Shafts: shaft material compatible with bearing type will be provided.

Bearing Type	Shaft Material
Std. linear ball brgs.	440C hardened & ground SS
Option "W" Rulon® sleeve	Hard chrome plated SS
Option "X" Duralon® sleeve	Hard chrome plated SS

S – Grease fittings, Side

T – Grease fittings, Top

Building the Model Number in 3 Easy Steps

Step 2 Add sensors. Choices include proximity switches, snap action mechanical switches, 3-way air pilot switches, magnetically operated electronic sensors and reed switches. Complete with sensors – or brackets only.

Sensor Codes (Use "S000" if NO Sensors are desired)

Select a code for sensor type and indicate position

Example: S03 B

- E = Extend position only
- R = Retract position only
- B = Both extend & retract positions
- M = 3 sensors (See note 1)

• Sensors beginning with the letter "S" (Prox, Snap Action, Air Pilot) are actuated by "dogs" clamped to the guideshfts. • Sensors beginning with the letter "J" or "E" (Electronic sensors and reed switches) are actuated by a magnetic band on the piston.

Note 1: Mid position "M" not available on SE250 or SE375 with prox options (S01 thru S42). "M" not available on any model with S50, S51, or S60.

Step 2: Sensing Options

— **SO3B**
(4 Digits)

Model number will end here if no Shock, Stop, or Bumper Options are desired. Continue on to Step 3 if you need any of these options.

Proximity Switch w/Brackets & Actuators

Prewired w/ 6' Leadwire	Quick Disconnect w/2 M cord set	Quick Disconnect without cord set	Thread Size	Electrical Characteristics
S01 <input type="checkbox"/>	S02 <input type="checkbox"/>	S12 <input type="checkbox"/>	12mm	110v AC, 2-wire, w/LED
S03 <input type="checkbox"/>	S04 <input type="checkbox"/>	S14 <input type="checkbox"/>	12mm	24v DC, 2-wire, w/LED (NPN/PNP)
S05 <input type="checkbox"/>	S06 <input type="checkbox"/>	S16 <input type="checkbox"/>	12mm	24v DC, 3-wire, w/LED (PNP) Sourcing
S07 <input type="checkbox"/>	S08 <input type="checkbox"/>	S18 <input type="checkbox"/>	12mm	24v DC, 3-wire, w/LED (NPN) Sinking

Proximity Switch Brackets & Actuators Only

S40 <input type="checkbox"/>	12mm	Customer supplies the switches
S41 <input type="checkbox"/>	8mm	Customer supplies the switches
S42 <input type="checkbox"/>	5mm	Customer supplies the switches

Snap Action Mechanical Switches

Prewired w/ 6' Leadwire	Conduit Fitting Style Housing	Electrical Characteristics
S50 <input type="checkbox"/>	S51 <input type="checkbox"/>	SPDT 10 amp. capacity (N/A on SE250/SE375)

Air Pilot Switch

S60 Miniature 3-way air valve (N/A on SE250/SE375)

Magnetic Piston & Clamp-On Sensors ("J")

Single sensor –1" stroke min; Dual sensors –2" stroke min. Not available on SE250.

9 Ft. Prewired	Quick Disconnect w/5M cord set	Sensor Type	LED	Electrical Characteristics
J70 <input type="checkbox"/>	J71 <input type="checkbox"/>	Reed	Yes	5-120 VDC/VAC, 0.5 Amp Max, 10 Watt Max, SPST N.O., 3.5 Voltage Drop
J72 <input type="checkbox"/>	J73 <input type="checkbox"/>	Electronic	Yes	Sourcing PNP 6-24 VDC, 0.50 Amp Max, 1.0 Voltage Drop
J74 <input type="checkbox"/>	J75 <input type="checkbox"/>	Electronic	Yes	Sinking NPN 6-24 VDC, 0.50 Amp Max, 1.0 Voltage Drop

Magnetic Piston & Dovetail Style Sensors ("E")

For 1" Stroke & longer on all bores; Reed sensors not available on SE250 or SE375

9 Ft. Prewired	Quick Disconnect w/5M cord set	Sensor Type	LED	Electrical Characteristics
E70 <input type="checkbox"/>	E71 <input type="checkbox"/>	Reed	Yes	5-120 VDC/VAC, 0.03 Amp Max, 4 Watt Max, 2.0 Voltage Drop
E72 <input type="checkbox"/>	E73 <input type="checkbox"/>	Electronic	Yes	Sourcing PNP 6-24 VDC, 0.20 Amp Max, 0.5 Voltage Drop
E74 <input type="checkbox"/>	E75 <input type="checkbox"/>	Electronic	Yes	Sinking NPN 6-24 VDC, 0.20 Amp Max, 0.5 Voltage Drop
E76 <input type="checkbox"/>	E77 <input type="checkbox"/>	Reed	No	0-120 VDC/VAC, 0.5 Amp Max, 5 Watt Max, 0 Voltage Drop

Magnetic Piston

J800	Customer supplies the sensors and mounting clamps
E800	Includes Dovetail Mounting Rail; customer supplies the sensors

Prox Switches w/Brackets & Actuators

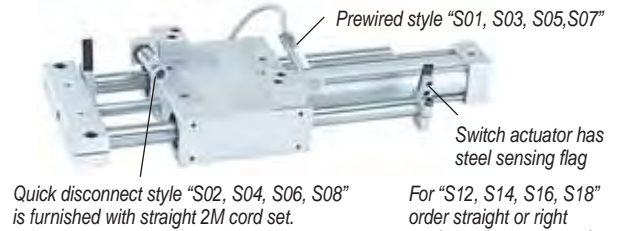

For "S12, S14, S16, S18" order straight or right angle cord set separately.

Female Cordsets w/2 Meter Leadwire for 12mm Proximity Switches

Option Code	Straight Cordset P/N	Rt. Angle Cordset P/N
S12	PCS01-2M	PCS02-2M
S14	PCS03-2M	PCS04-2M
S16	PCS05-2M	PCS06-2M
S18	PCS05-2M	PCS06-2M



4 meter and 6 meter cord sets are also available. Please consult factory.

Snap Action Mechanical Switches



Air Pilot Switches "S60"



Clamp On Style Sensors "J70 – J75"



Sensor clamps mount on the cylinder tie rods

Dovetail Style Sensors "E70 – E77"



Adhesive backed, double dovetail rail (tinted blue for illustration) bonds firmly to cylinder body; dovetail sensors slide and lock into mating slots in the rail.

"SE" Series Linear Slides

- Order Guide

Step 3

Standard mounting brackets are available for Ace or Enidine.
Stop collars are available for adjustability of stroke.

Step 3: Shock, Stop, & Bumper Options

- AB - KE

Shock Absorbers Options

For SE500 through SE1500 Slides Indicate desired option quantity/location in the box () as follows: **E** = Extend position; **R** = Retract position; **B** = Option located in both extend and retract position. (Stop collars are shown for position only and must be specified separately if desired.)

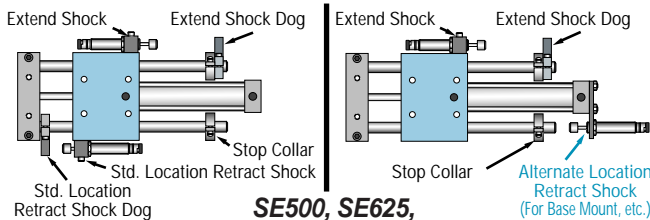

SE500, SE625,
SE750 and
SE1000 Slides

Standard Location

Alternate Location

Codes

Codes

- | | | |
|-----------------------------------|---------------------------------------|-----------------------------------|
| A <input type="checkbox"/> | Ace Shocks | D <input type="checkbox"/> |
| B <input type="checkbox"/> | Enidine Shocks | E <input type="checkbox"/> |
| C <input type="checkbox"/> | Brackets & Actuators only | F <input type="checkbox"/> |
- (Customer supplies the shocks)

Insert E, R or B in box

Insert R or B in box

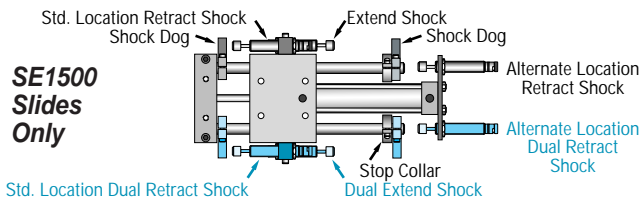

SE1500
Slides
Only

• for Dual Shocks Model SE1500 only: Insert "X" after code letter to denote Dual Shocks

Example: "DXB" provides four shocks - 2 standard location extend shocks and 2 alternate location retract shocks

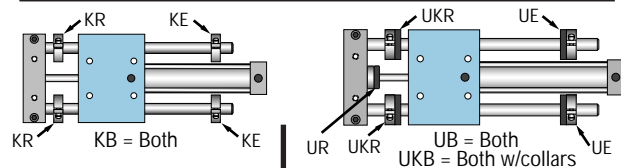

Stop Collars

for stroke adjustment.

- KE = Extend only
- KR = Retract only
- KB = Extend & retract

Use of "KR" reduces useable stroke length on SE250 & SE375. SE250 stroke loss = 3/16"; SE375 stroke loss = 1/8".

Urethane Bumpers

Bumpers not compatible with prox, snap-action, or air pilot switches. If sensors are desired use magnetically operated "J" or "E" Options.

- UE = Extend only w/stop collars
- UR = Retract only, no stop collars
- UB = Both w/stop collars extend
- UKR = Retract only with stop collars
- UKB = Both with stop collars both

Bumpers result in some stroke loss. See page 35

Extend Bumpers or Stop Collars not compatible with -Jxx sensors on SE375

Thin Parts Placers

Standard transition plates are available for joining two SE Series slides to create extremely compact 2-axis motion devices. The bearing block of the vertical unit is bolted to the transition plate which is mounted to the toolbar of the horizontal unit.

In cases where wider bearing separation is required on the horizontal unit (for longer strokes, heavier overhung loading, etc.), an EZ Series slide may also be combined with an SE Model.

Order transition plates by part number shown in the chart below. Order slides and accessories separately.

Trans. Plate P/N	TPL01	TPL02
Horizontal Slide	SE250	SE375
Vertical Slide	SE250	SE250
"A" Dimension	1.63	1.63
"B" Dimension	.63	.63
"C" Dimension	.56	.56

3-Position Tandem Cylinder Models

Available on SE500, SE625, SE750, SE1000 and SE1500

Principle of Operation

Generally, when two 4-way valves are used to actuate a 3-position slide, separate regulators supply each valve. A self-relieving regulator, upstream of the valve controlling the primary cylinder, is set at 20 to 40 psi lower than the secondary cylinder supply.

Flexibility in creating custom linear motions

Slide Combinations – Transition Plate Part Numbers – Dimensions

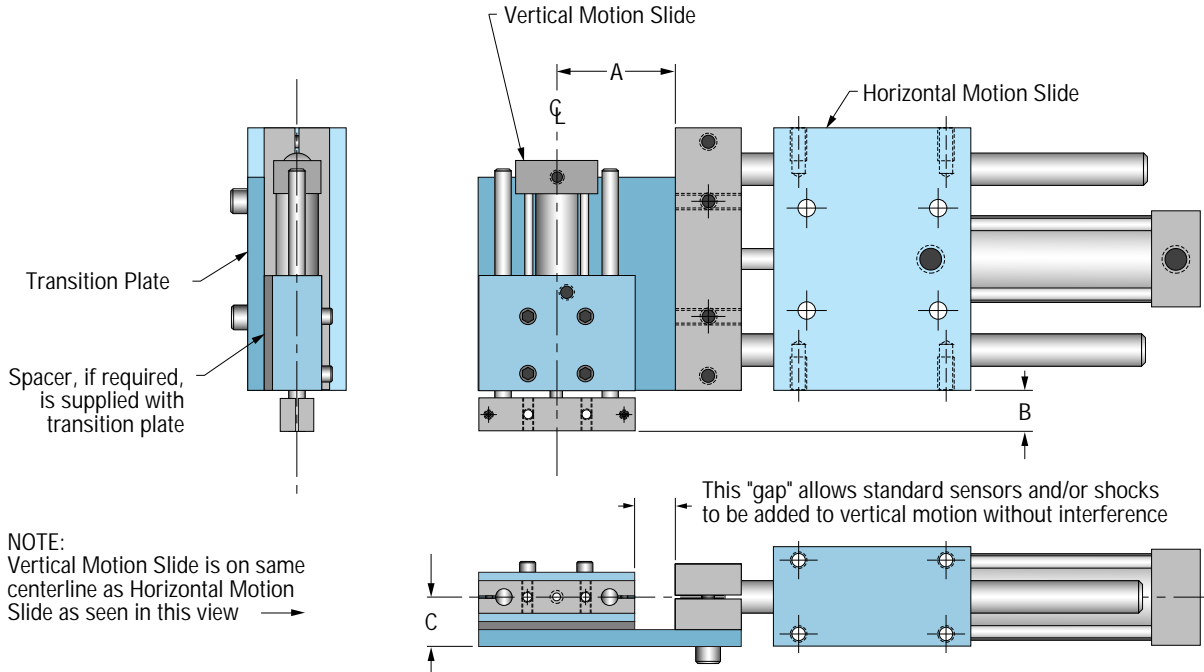

TPL03	TPL04	TPL05	TPL06	TPL07	TPL08	TPL09	TPL10	TPL11	TPL12	TPL13	TPL14	TPL15	TPL16	TPL17	TPL18	TPL19
SE375	SE500	SE500	SE500	SE625	SE625	SE625	SE750	SE750	SE750	SE750	SE1000	SE1000	SE1000	SE1000	SE1500	SE1500
SE375	SE250	SE375	SE500	SE375	SE500	SE625	SE375	SE500	SE625	SE750	SE500	SE625	SE750	SE1000	SE750	SE1000
2.00	1.63	2.00	3.25	2.00	3.25	3.38	2.00	3.25	3.38	5.00	3.25	3.38	5.00	6.00	5.00	6.00
1.00	.63	1.00	1.50	1.00	1.50	1.50	1.00	1.50	1.50	2.25	1.50	1.50	2.25	2.75	2.25	2.75
.75	.75	.75	1.00	.75	1.00	1.00	1.13	1.13	1.13	1.75	1.50	1.50	1.75	2.00	2.00	2.25

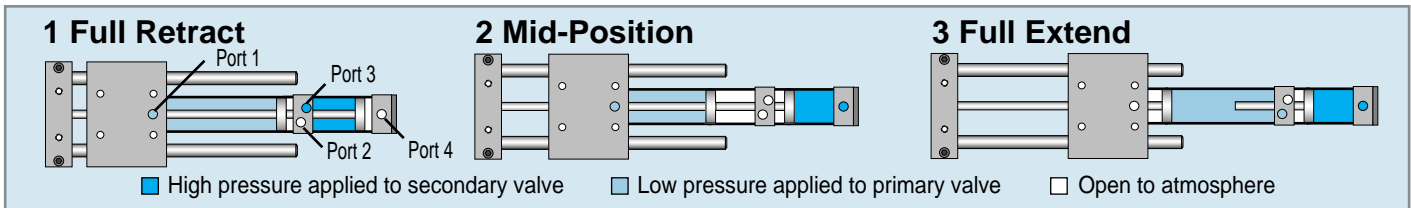

Step 1 – In the retract position, ports 1 & 3 are pressurized.

Step 2 – High pressure applied at port #4 will override pressure at port #1 and extend the secondary cylinder to its full stroke pushing the primary cylinder forward to mid-position. Exhaust air from the primary cylinder is

forced back through the valve and out the self-relieving regulator to atmosphere.

Step 3 – Shifting the primary cylinder's 4-way valve to apply pressure to port #2 extends the slide to full extend position, "uncoupling" the primary piston from the secondary piston rod.

The slide can now be retracted to its mid-position by shifting the primary valve (retracting the primary piston until it stops against the extended secondary piston rod) – or the slide can be fully retracted by shifting both the primary and secondary valves.

"SE" Series Linear Slides

Standard Mounting Style –MS1

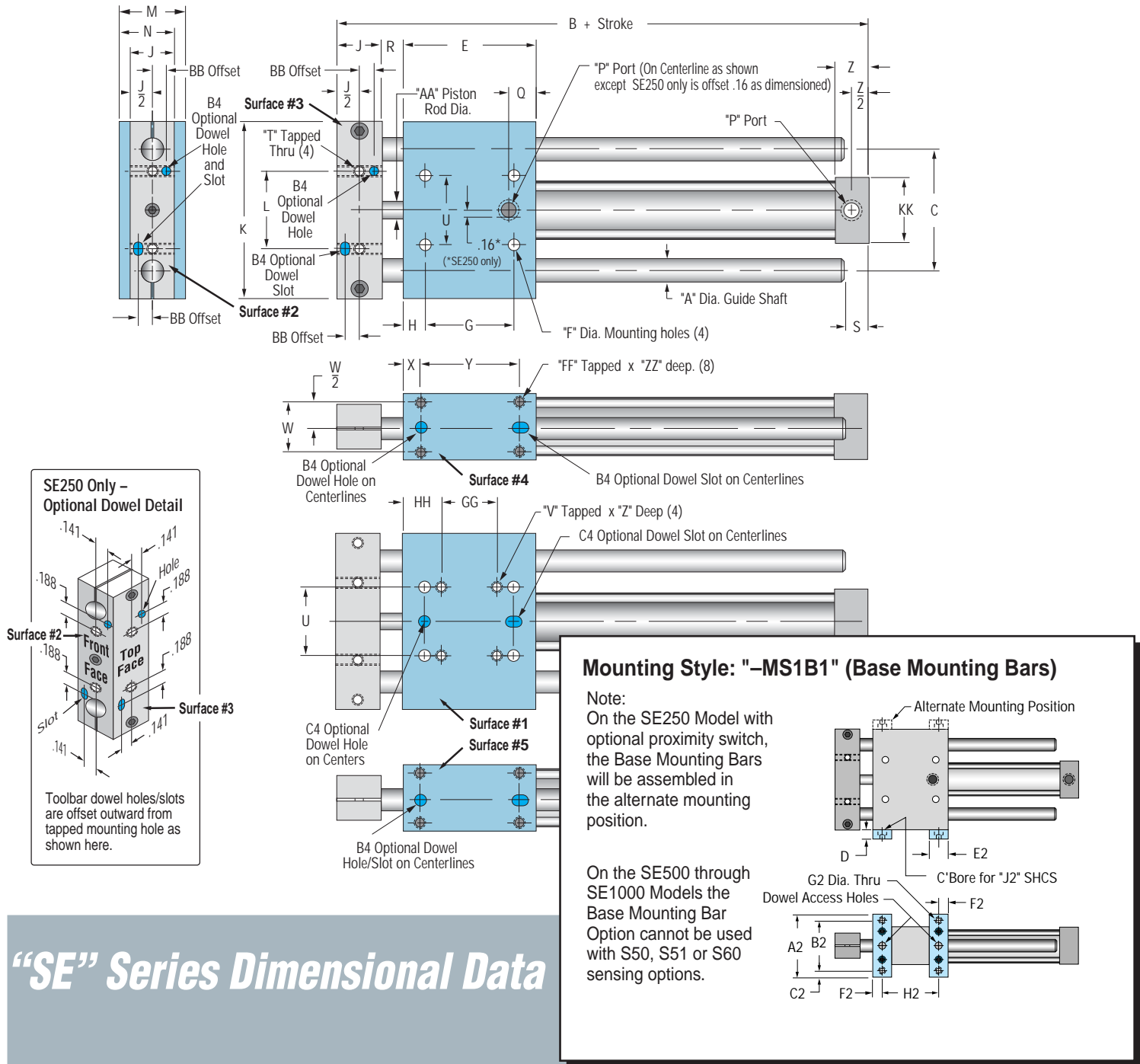

"SE" Series Dimensional Data

Model	Bore	A	A2	B	B2	C	C2	D	E	E2	F	F2	G	G2	H	H2	J	J2	K	L	M	N	P Port
SE250	1/2	1/4	1.38	3.13	1.063	1.625	.16	.25	1.75	.50	.173	.25	.875	.128	.25	1.250	.50	#5	2.38	.875	.75	.625	#10-32
SE375	3/4	3/8	1.75	4.50	1.375	2.000	.19	.25	2.00	.50	.204	.25	.750	.169	.38	1.500	.75	#8	3.00	1.000	1.00	.875	1/8 NPT
SE500	1-1/8	1/2	2.50	6.00	2.000	2.750	.25	.38	3.00	.75	.266	.38	2.000	.196	.50	2.250	1.00	#10	4.00	1.750	1.50	1.250	1/8 NPT
SE625	1-1/8	5/8	2.50	7.00	2.000	3.250	.25	.38	4.00	.75	.266	.38	3.000	.196	.50	3.250	1.00	#10	4.75	1.750	1.50	1.250	1/8 NPT
SE750	2	3/4	4.00	8.63	3.250	4.500	.38	.75	4.25	1.00	.406	.50	2.750	.406	.75	3.250	1.50	3/8	6.38	2.750	2.50	2.000	1/4 NPT
SE1000	2-1/2	1	5.00	10.38	4.000	5.500	.50	1.00	5.00	1.25	.531	.63	3.000	.531	1.00	3.750	2.00	1/2	8.00	3.250	3.00	2.500	1/4 NPT
SE1500	3-1/4	1-1/2	6.00	13.75	5.000	7.500	.50	1.00	7.00	1.25	.656	.63	4.500	.531	1.25	5.750	2.50	-	11.00	4.250	4.00	3.250	3/8 NPT

Mounting Style Dimensions

3-Position Tandem Cylinder Models Available on SE500, SE625, SE750, SE1000 and SE1500

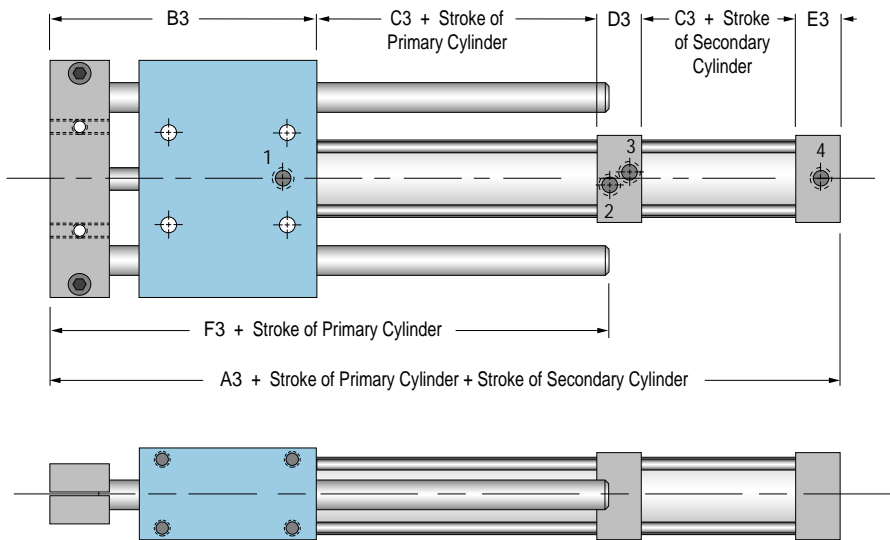

Tandem Model Dimensions						
Model	A3	B3	C3	D3	E3	F3
SE500	7.75	4.50	.75	1.00	.75	5.50
SE625	8.75	5.50	.75	1.00	.75	6.50
SE750	11.00	6.50	1.12	1.25	1.00	7.75
SE1000	13.50	7.75	1.12	2.00	1.50	9.12
SE1500	17.75	10.25	1.50	2.25	2.00	12.25

Dowel Holes

Fabco-Air Dowel Holes feature a slip fit dowel hole and a slip fit dowel slot, allowing 2 dowels to be pressed into the mounting surface or the end tooling. This "hole and slot" method provides precision alignment, yet dowel pin centerlines do not have to be held at a critical dimension.

Dowel holes/slots may be located on any of the five surfaces shown at the right and in blue on the dimension drawings on page 30.

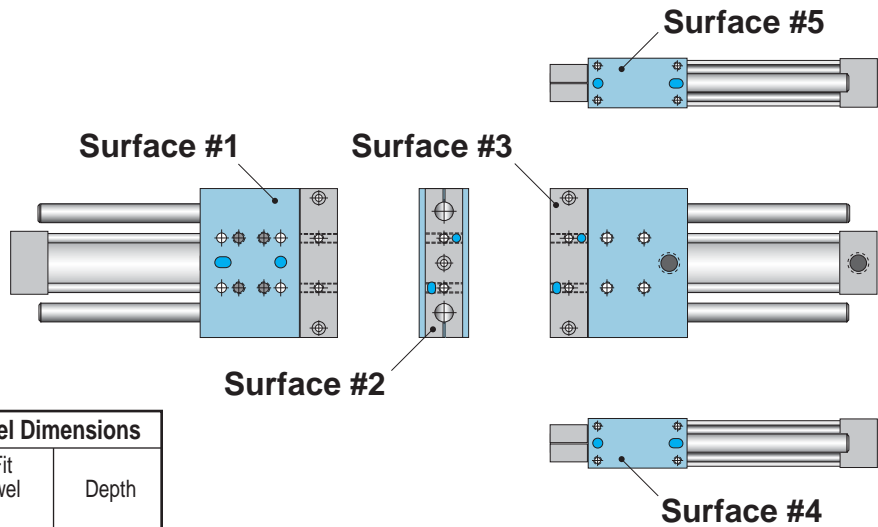

Model	B4 Dowel Dimensions		C4 Dowel Dimensions	
	Slip Fit for Dowel Size	Depth	Slip Fit for Dowel Size	Depth
SE250	3/32	.09	1/8	.12
SE375	1/8	.12	3/16	.18
SE500	3/16	.16	1/4	.25
SE625	3/16	.16	1/4	.25
SE750	1/4	.25	3/8	.37
SE1000	5/16	.37	3/8	.37
SE1500	3/8	.43	1/2	.50

Dowel Slot Detail

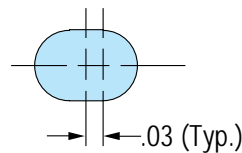

Integral Option: "-Y" (Hollow Guide Shafts)

Tubular guide shafts are available on SE750, SE1000 and SE1500. They can be used to reduce reciprocating weight – or to run air and/or electrical lines through the shafts.

Internal Diameters are as follows:

SE750	–	.44 ± .02
SE1000	–	.60 ± .03
SE1500	–	.89 ± .05

"SE" Series Linear Slides

Note: Proximity Switches shown are 12mm. Options S01, S03, S05 & S07 prewired styles are supplied with 6 ft. lead wire. Options S02, S04, S06 & S08 quick disconnect style are supplied with

straight 2 meter cord set. Options S12, S14, S16, S18 are quick disconnect style without cord sets. S40, S41 & S42 are brackets and actuators only, no switches.

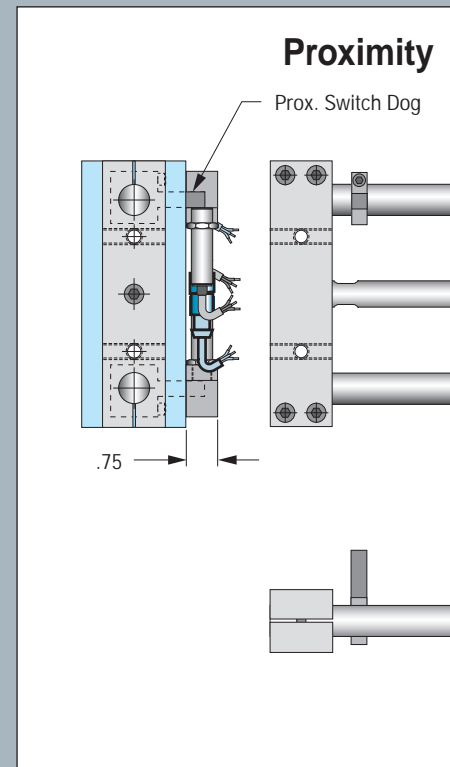
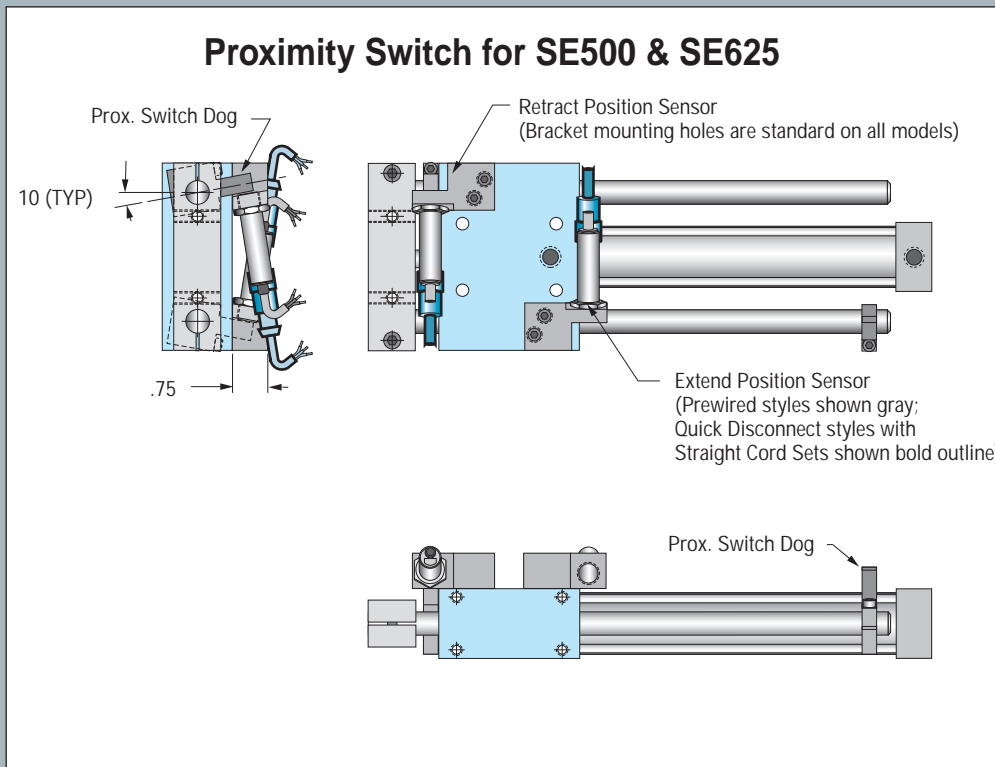
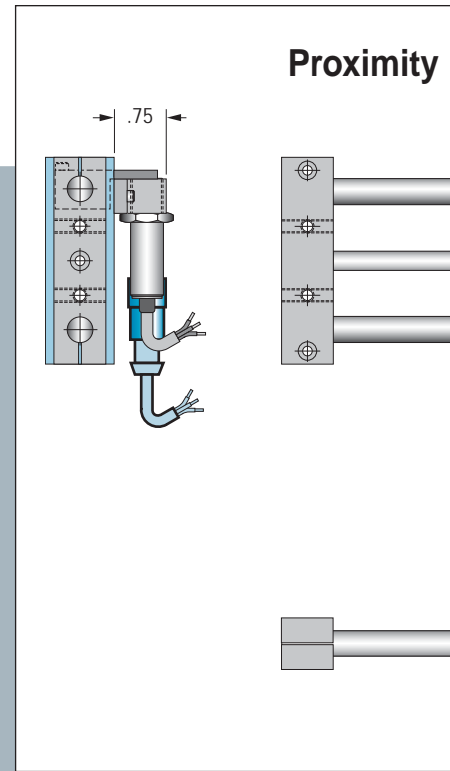
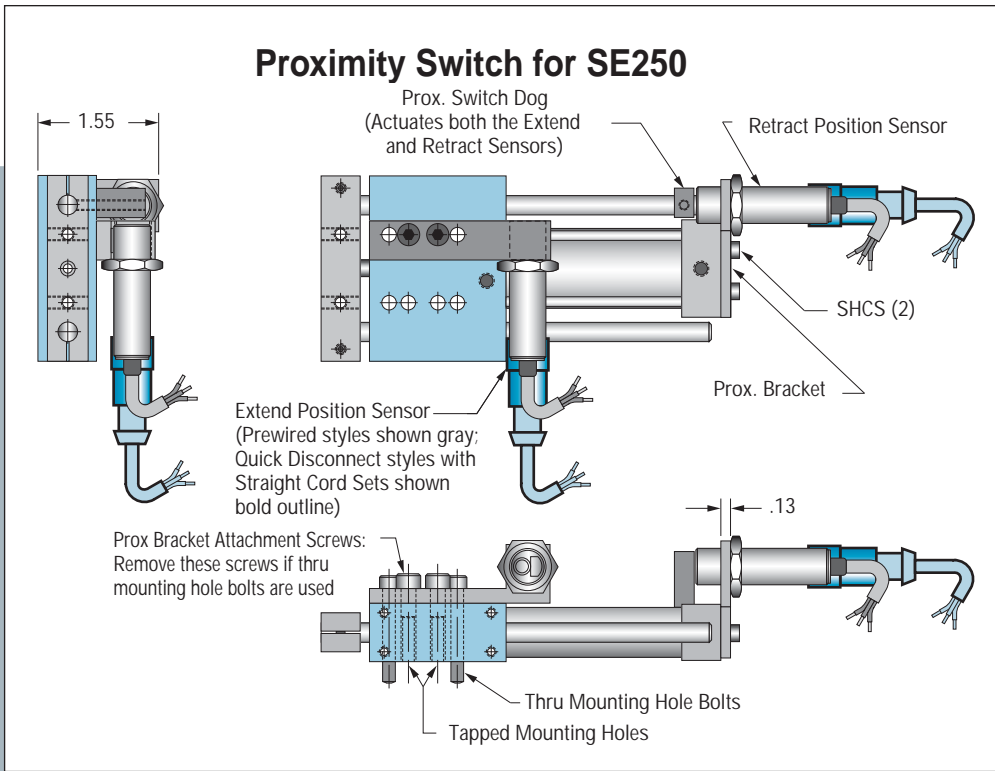

Proximity Switch, Snap Action & Air Pilot Switch Options

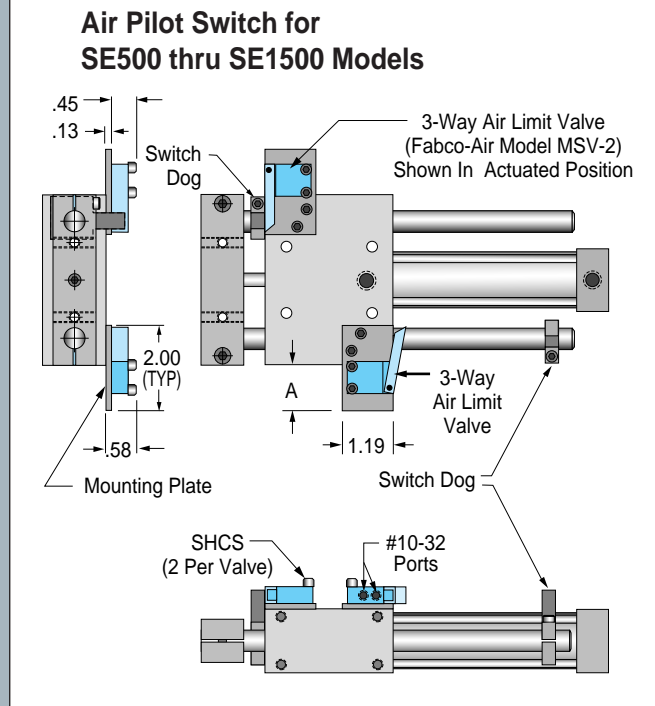
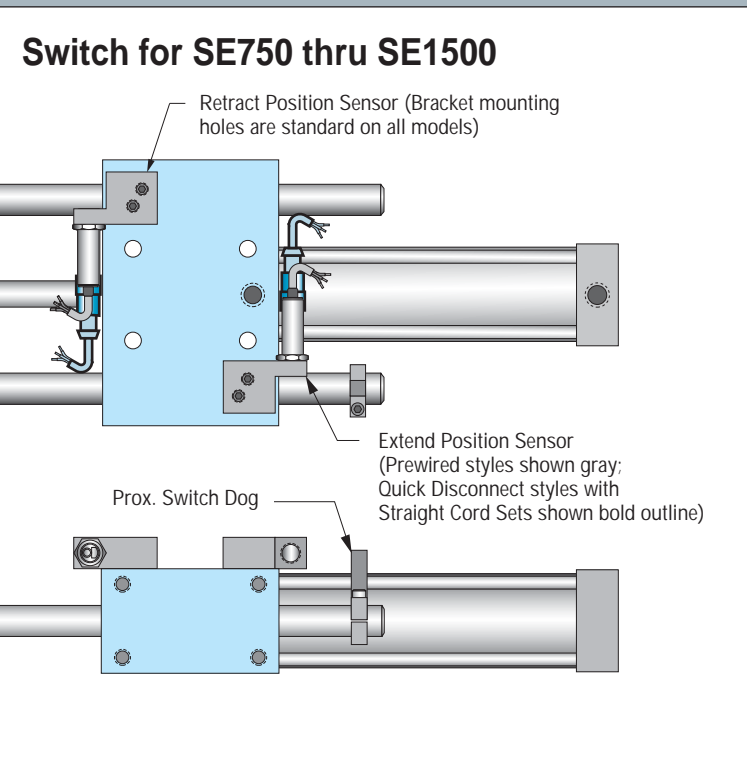
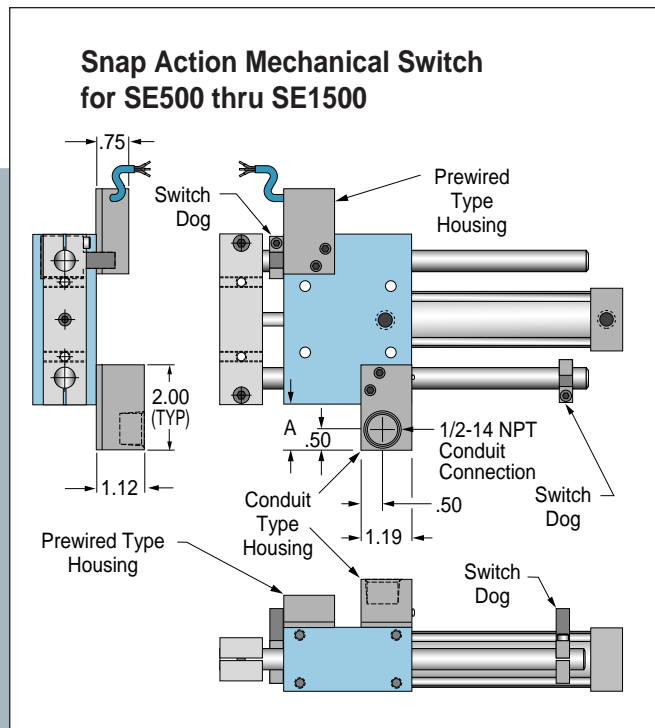
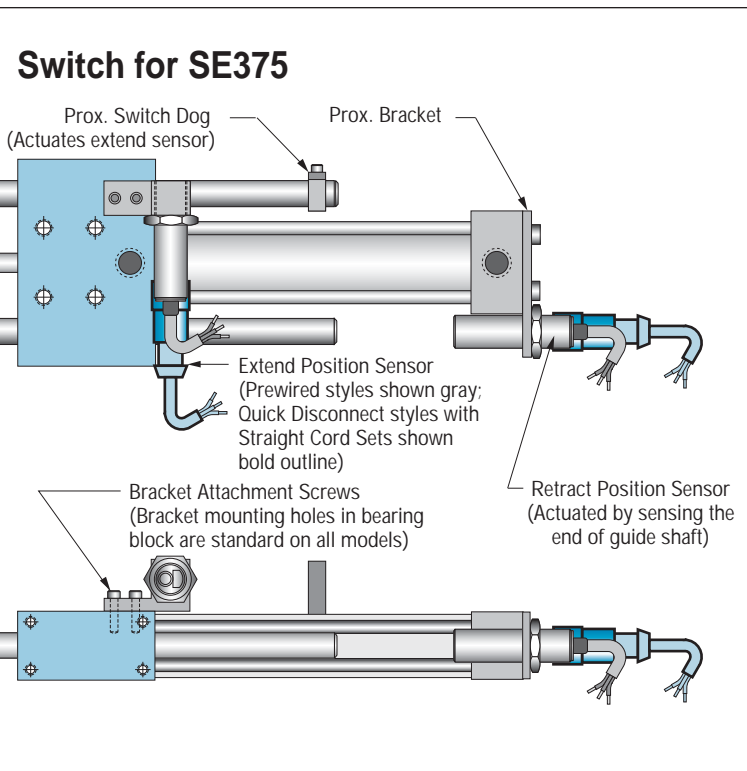

Snap Action & Pilot Switch Dimensions					
Model	SE500	SE625	SE750	SE1000	SE1500
A	1.06	.94	.75	.44	.00

"SE" Series Linear Slides

Shock Absorber Options

Standard Location – Codes (Insert E, R or B)

- A Ace Shocks
- B Enidine Shocks
- C Brackets & Actuators only

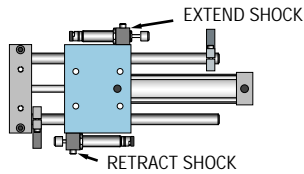

Alternate Location – Codes (Insert R or B)

- D Ace Shocks
- E Enidine Shocks
- F Brackets & Actuators only

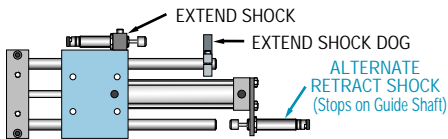

SE500 thru SE1000 Models

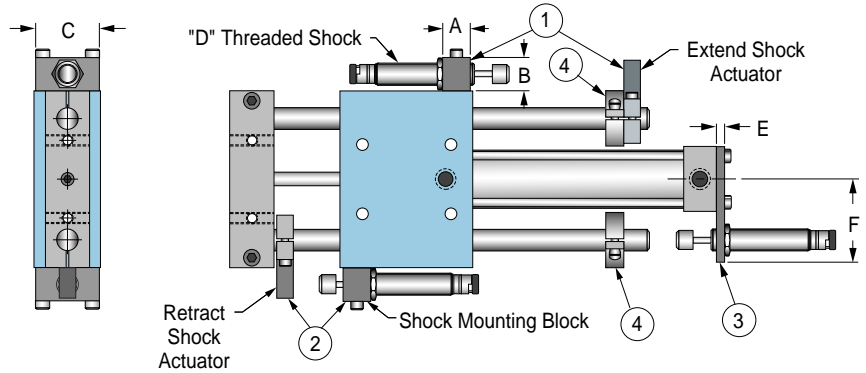

- ① Extend shock mounting package
- ② Standard retract shock mounting package

- ③ Alternate retract shock mounting package
- ④ Stop collars are compatible with all shock mounting packages.

Model	A	B	C	D	E	F
SE500	.62	.75	1.44	1/2-20	.19	1.88
SE625	.62	.75	1.44	1/2-20	.19	2.12
SE750	1.25	1.38	1.75	1.0-12	.38	3.00
SE1000	1.25	1.38	2.88	1.0-12	.38	3.53

SE1500 Model – Standard and Dual Shock Options

Standard Location – Option Codes (Insert E, R or B)

Single Shock Dual Shocks

- A AX Ace Shocks
- B BX Enidine Shocks
- C CX Brackets & Actuators only

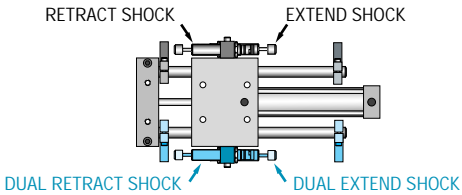

Alternate Location – Option Codes (Insert R or B)

Single Shock Dual Shocks

- D DX Ace Shocks
- E EX Enidine Shocks
- F FX Brackets & Actuators only

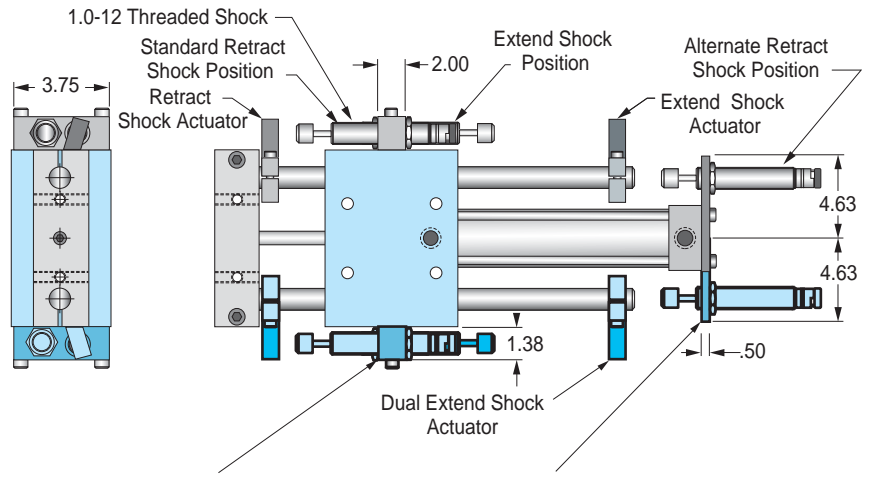
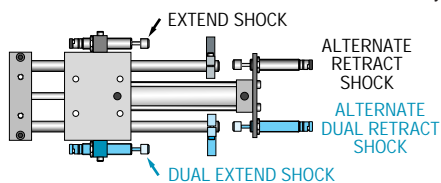

This shock mounting bracket is required only with applicable dual shock options

This retract shock mounting bracket (shown in bold outline) is required only with applicable alternate location, dual shock options

Shock Absorbers, Stops, Bumpers and Multi-Power® Units

Stop and Bumper Options

Stop Collars – SE250 thru SE1500 Models

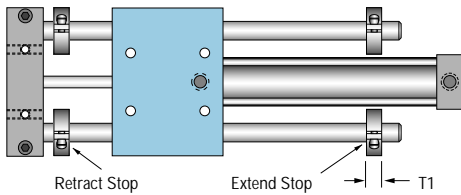

Bumper options use a combination of urethane washers and stop collars to create a cushioned stop. Bumpers are ideal for applications in which space limitations preclude use of hydraulic shock absorbers.
Note: The Bumper Option is NOT compatible with standard proximity switch, snap action switch or air pilot options. Extend Bumpers or Stop Collars not compatible with -Jxx sensors on SE375

Note 1: Retract stop collars reduce useable stroke length on SE250 & SE375. SE250 stroke loss = 3/16". SE375 stroke loss = 1/8"

Bumpers – SE250 thru SE1500 Models

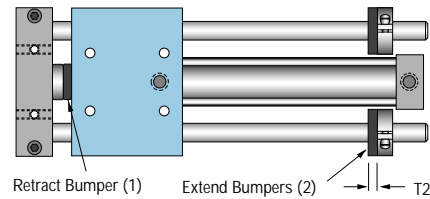

Model	SE250	SE375	SE500	SE750	SE1000	SE1500
T1	.28	.34	.41	.50	.50	.56
T2	1/8	1/8	1/8	1/8	1/4	1/4

Note 2: Bumper stroke losses all models.
 Code UE = 1/16"; Code UR = 1/8"; Code UB = 3/16"

Note 3: Bumper stroke losses SE250 & SE375.
 Code UKR = 5/16" for SE250; Code UKR = 1/4" for SE375

Multi-Power® “Hi-Thrust” Slides

Get Increased Thrust Without Increasing the Cylinder Bore

Fabco-Air incorporates its famous Multi-Power® cylinder on SE and EZ Series slide models to increase slide thrust. For example, a 2-stage Multi-Power® cylinder on an SE750 Model increases thrust from 314 to 584 pounds at 100 psi supply pressure. The sketch at the right shows a cutaway view of a 3-stage Multi-Power® slide which would effectively raise thrust to over 850 pounds at the same 100 psi supply!

How it works

The cylinder uses multiple pistons attached to a common shaft. Each piston is isolated within its own chamber by means of baffles integral with the outer cylinder wall. Unique internal porting allows air pressure to simultaneously energize all pistons – thus multiplying the slide’s thrust.

Contact the factory for applicable Multi-Power® solutions for your high force requirements.

Note: Adding additional stages does increase the overall cylinder length.

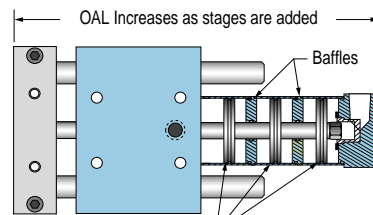

Three pistons attached to a common shaft nearly triple the output force of a conventional cylinder!



The cut-away view (left) illustrates the Multi-Power® principle in a 3-stage slide.



Shown above is an SE1000, 4-stage Multi-Power® slide capable of producing 1,830 pounds extend force at 100 psi supply pressure. A conventional cylinder would yield only 491 pounds of force at the same supply pressure.

"SE" Series Linear Slides

Specials

Alternate Adjustable Retract Stroke

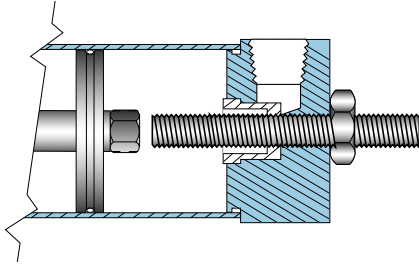

An adjusting screw with a thread sealing locknut mounted in the rear end cap provides a simple, yet rugged adjustment of the cylinder stroke in the retract direction. The fine thread of the adjusting screw provides precision adjustment.

Rear Piston Rod Extension

This special configuration consists of a modified rear end cap with rod seal and an extended piston rod, allowing various special application uses. By adding a simple compression spring and clamp collar, a vertical load can be held in mid-position and powered either downward or upward.

Other uses include special sensing and/or position feedback devices attached to the extended piston rod.

An extended rear piston rod added to a tandem cylinder option allows the slide to have a mid-position adjustment capability.

Alternate Adjustable Extend Stroke

Fabco-Air's popular Dial-A-Stroke® can be applied to most SE Series models for precise adjustability of extend strokes.

Operator Safety –

The stop tube, adjustment nut with skirt, and minimum clearances combine to eliminate pinch points.

Construction –

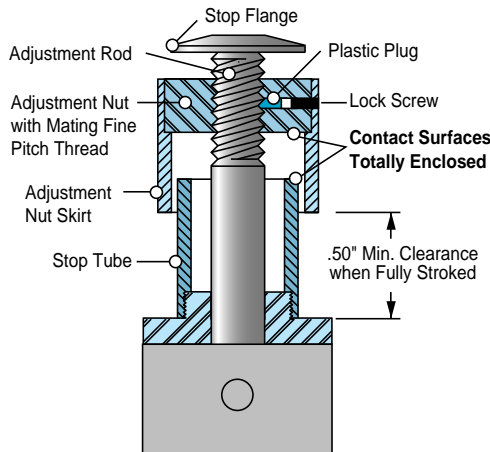

The stop tube is black anodized aluminum – the adjustment nut is blackened steel with a black anodized aluminum skirt – the stop flange is red anodized aluminum: all for corrosion resistance and appearance.

The adjustment nut, steel for long life, includes a lock screw with a plastic plug so the adjustment nut can be locked

in place without damaging the threads. Precision adjustment is achieved with fine pitch threads on the adjustment rod.

The stop flange is mounted on the end of the adjustment rod so the nut will not come off during adjustment.

Adjustment –

Adjustment settings are simplified by convenient scale markings.

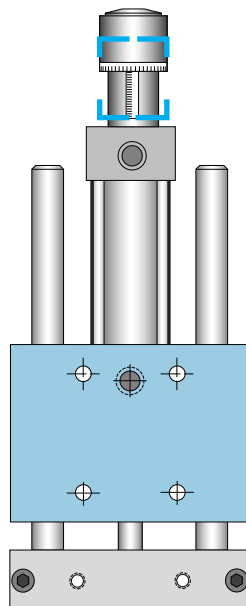

Step 1

SE500 – 5.0

Indicate "SE" series.

Select model size based on guide shaft dia.

Select a stroke (Special strokes also available)

Model Size	Guide Shaft Diameter	Bore
250	1/4"	1/2"
375	3/8"	3/4"
500	1/2"	1-1/8"
625	5/8"	1-1/8"
750	3/4"	2"
1000	1"	2-1/2"
1500	1-1/2"	3-1/4"

Model Standard Stroke Length

SE250	1/2" to 4" by 1/2" increments
SE375	1" to 6" by 1" increments
SE500	1" to 10" by 1" increments
SE625	1" to 10" by 1" increments
SE750	1" to 6" by 1" increments 8" to 18" by 2" increments
SE1000	1" to 6" by 1" increments 8" to 20" by 2" increments
SE1500	2" to 30" by 2" increments

How to Order Summary

–MS1 T3

Choose
Mounting Style
& Toolbars

Mounting Styles

MS1 = Standard Mounting

Includes: • Tapped mounting holes

- Thru mounting holes
- Side tapped mounting holes

MS1B1 = Base Mounting Bars (1 Pair)

Toolbars

- T1 = Blank Toolbar
- T3 = Toolbar for Model SE500 to attach an SE500 or an EZ500
- T4 = Toolbar for Model SE1000 to attach an SE500, EZ500, SE750 or EZ750

Integral Options

D – Dowel Hole and Slot
Specify Surface Location(s)
1, 2, 3, 4, or 5 in box(es)

H – Hydraulic Cylinder Seals

V – Viton Cylinder Seals

Bearing Options

W – Rulon® Sleeve Bearings

X – Duralon® Sleeve Bearings

Guide Shaft Options

Y – Hollow Guide Shafts

Z – Stainless Steel Guide Shafts

S – Grease fittings, Side

T – Grease fittings, Top

– VZS

Select
Integral
Options

Step 2

– S03B

Sensor Options

Sensor Options

S000 – Indicates **NO SENSORS** desired

Note: Indicate sensor location in the box .

E= Extend, **R**=Retract, **B**=Both Extend & Retract, **M**=3 Sensors

S01 thru **S18**

12mm Prox Switch w/Brackets & Actuators

- Choose desired electrical characteristics
- Choose pre-wired or quick disconnect with or without cord set

S40 thru **S42**

Prox Switch Brackets & Actuators Only, no Switches.

- Choose 12mm, 8mm, or 5mm

S50 , **S51** (E, R or B only)

Snap Action Mechanical Switches

- Choose pre-wired or with conduit fitting

S60 (E, R or B only)

Air Pilot Switch

J70 thru **J75** (**Not available on SE250**)

Magnetic Piston and Clamp-on Sensors.

- Choose reed or electronic (PNP or NPN)
- Choose pre-wired or quick disconnect with cord set

Single sensor – 1" stroke min.

Dual sensors – 2" stroke min.

J800

Magnetic Piston Only, No Sensors

E70 thru **E77**

Magnetic Piston & Dovetail Style Sensors

- Choose reed or electronic (PNP or NPN)
- Choose pre-wired or quick disconnect with cord set.

Requires 1" or longer stroke. Reed switches not available on SE250 or SE375.

E800

Magnetic Piston & Dovetail Mounting Rail (attached) only, no sensors. Requires 1" or longer stroke

Step 3

– CB – KE

Select Shock Ab-
sorber, Bumper,
and Adjustable
Stop Options

Shock Options

Specify **E**, **R**, or **B** in box .

A – Ace Shocks

B – Enidine Shocks

C – Brackets and
actuators only

Alternate Location

Specify **R** or **B**

D – Ace Shocks

E – Enidine Shocks

F – Brackets and
actuators only

Dual Shock Options for Model SE1500 only

Specify **E**, **R**, or **B** in box

AX – Ace Shocks

BX – Enidine Shocks

CX – Brkts & actuators

Alternate Location

Specify **R**, or **B** in box

DX – Ace Shocks

EX – Enidine Shocks

FX – Brkts & actuators

Other Options

KE – Stop collars, extend

KR – Stop collars retract

KB – Stop collars both

UE – Bumpers extend
with stop collars

UR – Bumpers retract only
without stop collars

UB – Bumpers both ends
w/stop collars extend

UKR – Bumper retract only
with stop collars

UKB – Bumpers both ends
with stop collars both
ends

“EZ” Series Linear Slides

Optional Dowel Hole/Slot

Code -D

Optional slip fit dowel holes and slip fit dowel slots allow for repeatably precise slide mounting and/or attachment of end tooling. Option may be specified at any of the five surface locations (1 - 4, 6) listed here.

#1 - MH1/MH2 end cap mounting surface (bottom mounting surface)

#2 - Toolbar face

#3 - Toolbar top

#4 - MV1/MV2 end cap mounting surface (side mounting surface)

#6 - MF1/MF2/MF3 end cap mounting surface (flange face)

Cylinder Endcaps

Clear anodized aluminum with precision machined mounting surface

Choice of endcap mounting styles

Code - MH1: Thru-hole mounting (shown)

Code - MH2: Bottom tapped mounting hole

Code - MF1/MF2/MF3: Flange mount styles

Code - MV1/MV2: Side tapped hole mounting

Unique design - Integral air cylinder with end caps that serve as rugged housings for the linear ball bearings. Cylinder stroke is nominal $+.015" / -.000"$ with $\pm .001"$ repeatability.

Dowel Surface 3

Dowel Surface 2

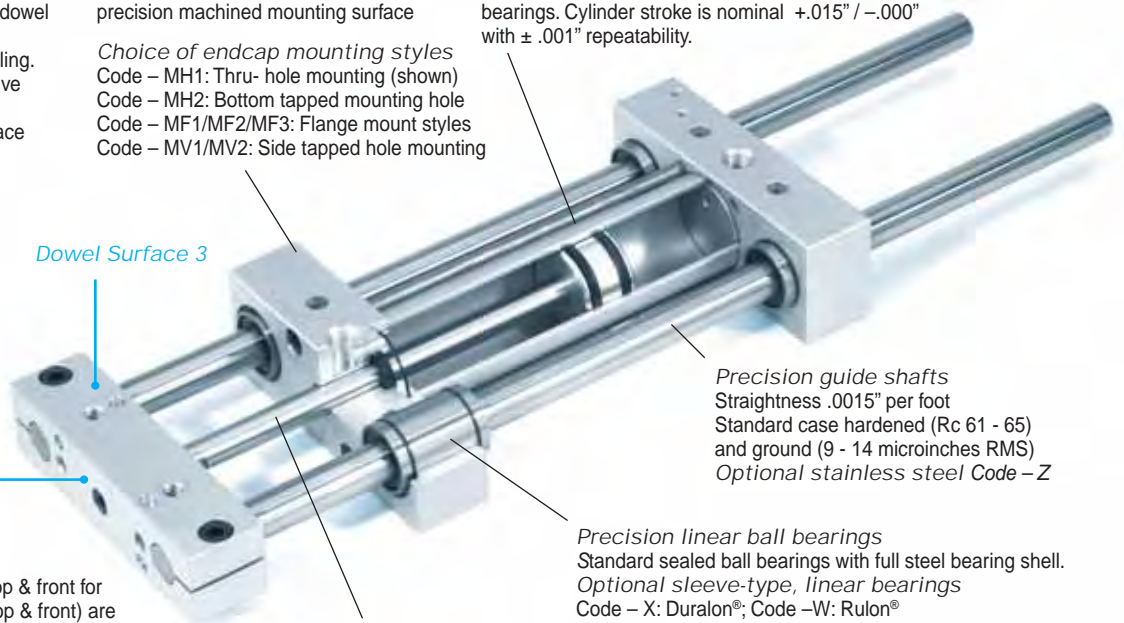

Precision guide shafts

Straightness $.0015"$ per foot
Standard case hardened (Rc 61 - 65)
and ground (9 - 14 microinches RMS)
Optional stainless steel Code -Z

Precision linear ball bearings

Standard sealed ball bearings with full steel bearing shell.
Optional sleeve-type, linear bearings
Code - X: Duralon®; Code -W: Rulon®

Front Toolbar

Clear anodized aluminum, machined top & front for squareness. Tapped mounting holes (top & front) are standard. Optional slip fit dowel holes and slip fit dowel slots assure repeatably precise tooling attachments.

Code - T1: Optional blank toolbar (no mtg holes)

Codes -T3 or T4: Optional toolbars for joining dissimilar slides together. SE and EZ Series can be combined for 2-axis motion.

Stainless steel piston rod - End of piston rod is piloted into the back of the toolbar by a precision machined counterbore. A socket head cap screw completes attachment to the toolbar. This design eliminates piston rod side loads, increasing cylinder seal life and improving performance.

Engineering Data

Model	EZ250	EZ375	EZ500	EZ625	EZ750	EZ1000	EZ1500
Guide Shaft Diameter	1/4"	3/8"	1/2"	5/8"	3/4"	1"	1-1/2"
Bore	1/2"	3/4"	1-1/8"	1-1/8"	2"	2-1/2"	3-1/4"
Power Factor Extend	.20	.44	.99	.99	3.14	4.90	8.27
Power Factor Retract	.17	.39	.88	.88	2.84	4.47	7.51
Weight, lbs. @ zero stroke	.46	1.10	2.40	3.35	8.31	19.10	53.30
Weight per inch of stroke	.06	.18	.32	.44	.74	1.19	2.60
Standard Strokes	1/2" thru 4" by 1/2" incr.	1" thru 6" by 1" incr.	1" thru 10" by 1" incr.	1" thru 10" by 1" incr.	1"- 6" by 1" 8"-18" by 2"	1"- 6" by 1" 8"-20" by 2"	2" thru 30" by 2" incr.

Max Operating Pressure: 150 psi

Output Force: Output Force in Pounds = Pressure x Power Factor

Speed: Speeds up to 24 inches per second are obtainable by utilizing an optional stop package in conjunction with urethane bumpers or hydraulic shocks. Moderate reciprocating loads can be safely cycled up to 12 inches per second by utilizing an adjustable stop option without bumpers or shocks. Except for light loads and moderate speeds, operating EZ slides without an adjustable stop option is **not** recommended. Moderate to heavy loads should **not** be stopped by bottoming the piston against the end cap.

Important note: Most linear slide failures are caused by severe, damaging impact loads (which act like a "slide hammer" on the piston rod). Proper slide model sizing, use of adjustable stops and/or shocks/bumpers, and operating the slide at the lowest possible air pressure will insure successful operation and long product life.

Accuracy: EZ Series slides feature linear ball bearings for near play free operation. Each bearing has $.0005"$ max "play" or less. The built-in air cylinder will stroke $+.015" / -.000"$ of nominal stroke. Stroke repeatability is $\pm .001"$. Guide shaft straightness tolerance is $.0015"$ per foot of shaft.

Bearings in the "EZ" series slides are housed in the cylinder end caps. As the stroke increases, the pairs of bearings become spaced further apart, increasing bearing load capacity. Note: when comparing "EZ" charted Load #1 capacities to "SE" model/stroke equivalents, ratings are identical because the limiting factor is the strength of the guideshaft to resist bending, not the linear ball bearing capacity. When sleeve type bearings (code "X" or "W") are specified, the "EZ's" additional bearing separation can be a significant factor in improving bearing life and reducing toolbar "play" in Load #1 applications.

Ideal for high precision, high load carrying capacity applications

Load Sizing Guide

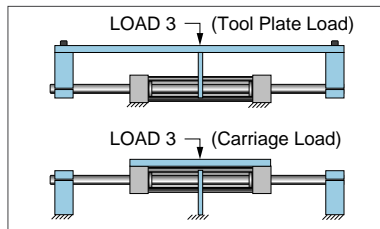
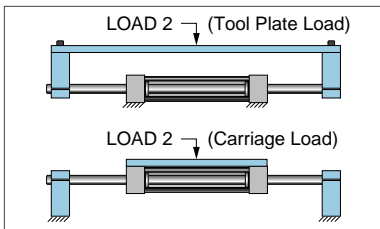
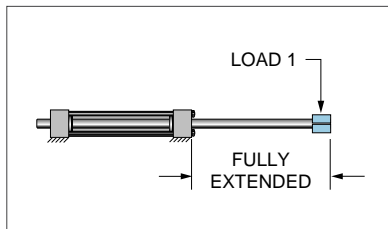

Safe loading involves a combination of factors including: bearing capacity, shaft strength and allowable deflection, life expectancy, how the load is applied, and how fast the load is accelerated/ decelerated. – **DO NOT OVERLOAD** – Overloading can cause reduced product life, shaft bending and loss of positional accuracy, as well as bearing and seal failure. **CAUTION:** Heavy reciprocating loads can create damaging impact forces at end of stroke. It may be necessary to use adjustable stops, bumpers, or hydraulic shock absorbers – or reduce speeds.

Center support can be added to EZ500 and larger slides. Center support dramatically reduces deflection and increases load capacity on long stroke applications.

SAFE LOADS (lbs.)

Model	Load Type	Stroke															Maximum Deflection					
		1"	2"	3"	4"	5"	6"	7"	8"	9"	10"	12"	14"	16"	18"	20"						
EZ250	Load 1	4.0	2.4	1.8	1.3												.005"					
		17	10	4.0	2.5												.015"					
EZ250	Load 2	40	24	8.0	4.0												.005"					
		48	44	38	19												.015"					
EZ375	Load 1	28	28	12	6.0	4.0	2.8										.005"					
		28	28	28	18	12	6.8										.015"					
EZ375	Load 2	60	36	14	8.6	3.6	2.0										.005"					
		79	79	60	33	18	13										.015"					
EZ500	Load 1	84	44	24	12	8.0	6.0	4.0	3.0	1.8	1.4						.005"					
		120	120	60	36	24	16	12	8.2	6.0	4.8						.015"					
EZ500	Load 2	136	72	44	24	21	14	12	8.0	7.0	5.4						.005"					
		290	210	120	84	60	44	29	24	20	15						.015"					
EZ500	Load 3	290	290	220	160	116	80	64	48	37	28						.030"					
		290	290	264	144	126	84	72	56	49	36						.005"					
EZ625	Load 1	150	84	44	28	16	12	9.0	7.8	5.6	4.0						.005"					
		150	150	124	76	56	34	26	20	16	11						.015"					
EZ625	Load 2	240	140	84	60	40	36	22	17	12	10						.005"					
		420	420	250	160	120	84	60	56	34	30						.015"					
EZ625	Load 3	420	420	420	310	220	170	120	96	70	60						.030"					
		420	420	420	420	245	184	115	100	72	64						.005"					
EZ750	Load 1		100		56		20		12		8.0	5.0	4.0	2.2	1.8		.005"					
			280		114		56		36		26	12	9.0	6.4	5.8		.015"					
EZ750	Load 2		180		64		42		36		15	12	8	7	6		.005"					
			450		190		110		80		44	24	17	14	12		.015"					
EZ750	Load 3		480		360		200		140		76	50	35	26	24		.030"					
			480		480		380		200		136	76	60	42	34		.005"					
EZ1000	Load 1		200		80		44		36		24	12	8	6	5	4.0	.005"					
			470		220		120		80		50	36	24	17	13	12	.015"					
EZ1000	Load 2		240		110		80		66		50	42	38	32	30	24	.005"					
			600		320		210		156		100	90	76	50	40	36	.015"					
EZ1000	Load 3		600		600		400		280		200	150	124	100	80	70	.030"					
			600		600		540		430		320	210	156	90	84	70	.005"					
EZ1500			Stroke																			
					4"			6"				12"				18"			24"			30"
EZ1500	Load 1				600			510			124			76			50			10	.005"	
					800			600			300			124			70			30	.015"	
EZ1500	Load 2				825			800			434			275			195			60	.005"	
					920			920			750			480			335			90	.015"	
EZ1500	Load 3				920			920			920			590			410			115	.030"	
					920			920			850			450			250			85	.005"	

Single Overhead Support Beam– On stroke lengths longer than ten times the guide shaft diameter (Example: EZ625 is .625 x 10 = 6-1/4" stroke), a single beam increases "Load 1" by a factor of 1.9 to 1.

Twin Overhead Support Beam– On stroke lengths longer than ten times the guide shaft diameter (Example: EZ1000 is 1 x 10 = 10" stroke), a twin beam increases "Load 1" by a factor of 2.7 to 1.

“EZ” Series Linear Slides – Order Guide

Step 1 Select a slide model size, stroke length, endcap mounting style, plus any optional toolbar, mounting bar (B1) or integral option (such as Viton seals, etc.).
 Helpful hint: **The model size = guide shaft diameter in 3 decimal places.**

Step 1: Basic Slide Model

EZ 750 – 5.0 (– OPTIONAL TANDEM CYLINDER STROKE)

Series Model Size Stroke

Model Size	Guide Shaft Diameter	Bore	Standard Stroke Length
250	1/4"	1/2"	1/2" to 4" by 1/2" increments
375	3/8"	3/4"	1" to 6" by 1" increments
500	1/2"	1-1/8"	1" to 10" by 1" increments
625	5/8"	1-1/8"	1" to 10" by 1" increments
750	3/4"	2"	1" to 6" by 1" increments 8" to 18" by 2" increments
1000	1"	2-1/2"	1" to 6" by 1" increments 8" to 20" by 2" increments
1500	1-1/2"	3-1/4"	2" to 30" by 2" increments

3-Position Tandem Cylinder Slides

(Not available on SE250)

Note: See pages 28 & 29 for principle of operation

Ordering example:

EZ750 – 5.0 – 2.0 – MH2 – S03B – RC01CB

Primary Cylinder Stroke Secondary Cylinder Stroke

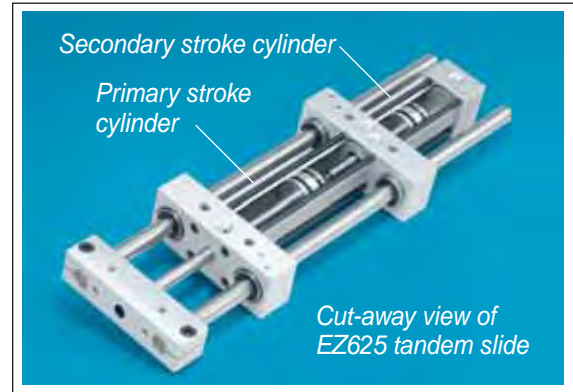

Sensor locations– use “M” in the Box (□) if mid-position sensor is required (3 sensors). Note: “M” (mid-position) is **not** available with “S50, S51, S60” sensors. All sensors are located on the primary cylinder, which also contains the magnetic piston band for “E” & “J” options. Mid-position “M” prox sensor is **not** available on “EZ375” models with “S01” through “S47” prox options (consider using “E” style sensors if mid-position sensing is required).

Port Locations: Top ports are standard on all tandem models. A top and bottom port combination is available for the EZ500 and EZ625 as a “special” order at no additional charge. Consult factory.

Optional “B1” Mounting Bars

For use with MV1 or MV2 Mounting style

To Order with Slide:

Add “B1” to mounting style

Example:

EZ500 – 5.0 – MV1B1

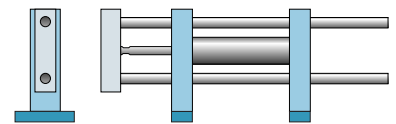

Floating Rear Bearing Block Option (NOT available on EZ250)

Puts maximum stroke within shortest possible envelope.

To order:

add “FRBB” after end cap mounting style and specify dimension “D”.

Ordering example: **EZ500 – 5.0 – MH2 – FRBB (D3.5)**

Options available:

Sensing options are limited to magnetically operated “E” & “J” Options. Tooling, Stop, and Shock options are **NOT** available.

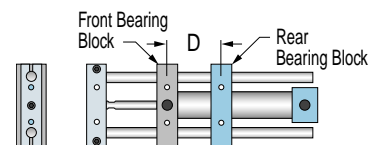

Rear floating bearing block can be positioned anywhere along the cylinder tube. See details on page 47.

Building the Model Number in 3 Easy Steps

Step 2 Please turn the page

Model Number Will End Here
If No Options Are Desired

– MV1B1T1
Mounting Style & Toolbars

Leave Blank If No Integral
Options Are Desired

– VZX
Integral Options

Continue on to step 2
if you want to add
Sensing Options.

Endcap Mounting Styles

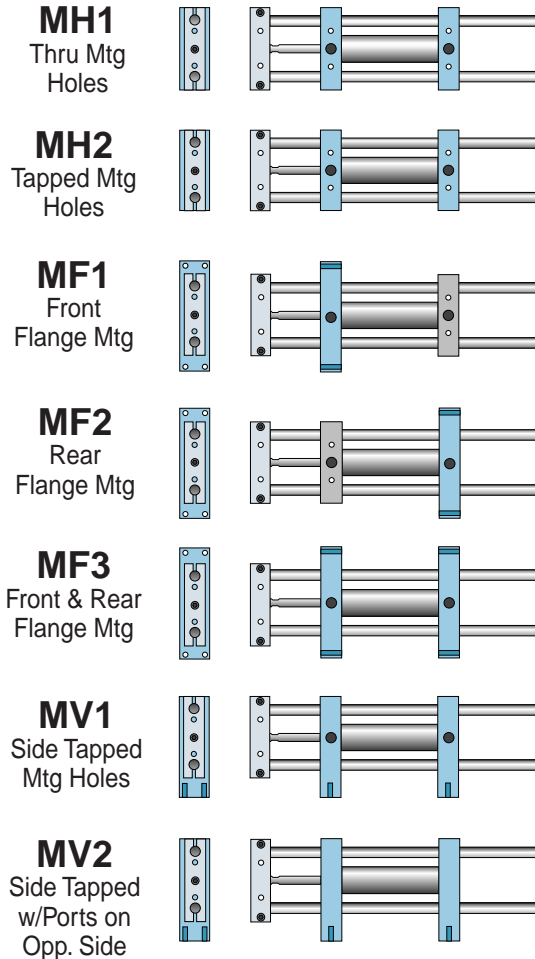

Integral Option Codes

D –

Dowel Hole/Slot Code & Location(s)
Available on any of the 5 mounting surfaces described
on page 38. **Example: D13 specifies
dowel hole/slot on bottom surface of bearing
blocks and on top surface of toolbar.**

H– Hydraulic Cylinder Seals (150 psi max.)

V– Viton Cylinder Seals

Bearing Options

Sleeve Bearings can be substituted for standard linear ball bearings.

W– Rulon® Shaft Bearings

X– Duralon® Shaft Bearings

Guide Shaft Options

Y– Hollow Guide Shafts

Case hardened & ground #52100 tubular steel
available on EZ750 Models and larger.

Z– Stainless Steel Guide Shafts: shaft material
compatible with bearing type will be provided.

Bearing Type

Std. linear ball brgs.

Option "W" Rulon® sleeve

Option "X" Duralon® sleeve

Shaft Material

440C hardened & ground SS

Hard chrome plated SS

Hard chrome plated SS

Toolbar Configurations

Optional toolbars, including blanks (with no holes), may be
substituted for standard toolbars at **no additional cost**.

All like models of EZ Series Slides (except EZ375 & EZ500)
can be joined together for two-axis motion using standard
toolbars. Toolbars with special mounting holes for joining
dissimilar models are shown in the table at right.
(Also see note 1)

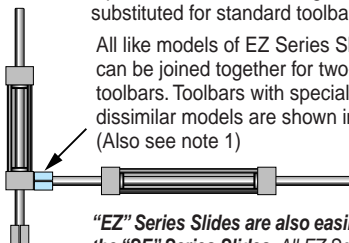

**"EZ" Series Slides are also easily combined with
the "SE" Series Slides. All EZ Series Slides except
EZ250 share identical tooling mounting bars with their
SE Series cousins.**

Toolbar Option Codes

– **T1** = Blank Toolbar (no mounting holes).

For joining dissimilar models, specify one of the horizontal toolbars listed below:

Horizontal Motion	Vertical Motion
– T2 for EZ375	EZ375
– T3 for EZ500	EZ500 or SE500
– T4 for EZ1000	EZ500, SE500, EZ750, or SE750

Note 1 – Using an "EZ" slide for the vertical motion is recommended only for light loads,
short vertical strokes or slow horizontal speeds. For more severe applications, a special
base plate should be attached to the endcaps of the vertical motion "EZ" slide. One end
of this plate is "sandwiched" between face of horizontal motion's toolbar and the front
endcap of the vertical motion "EZ" slide. Rear endcap is attached to plate's opposite end.

To order: Add "Option Code" to Mounting Style.

Example: EZ1000 – 10.0 – MH2T4

"EZ" Series Linear Slides – Order Guide

Step 2

Add sensors. Choices include proximity switches, snap action mechanical switches, 3-way air pilot switches, magnetically operated electronic sensors and reed switches. Available complete with sensors – or mounting brackets only if you are furnishing the sensors.

Step 2: Sensing Options Model Number Ends Here If No Other Options Desired

– **SO3B**
(4 Digits)

Sensor Codes (Use "S000" if NO Sensors are desired)

Select a code for sensor type and indicate position

Example: SO3 **B**

E = Extend position only
R = Retract position only
B = Both extend & retract positions
M = 3 sensors (See note 1)

- Sensors beginning with the letter "S" (Prox, Snap Action, Air Pilot) are actuated by "dogs" clamped to the guideshafts. • Sensors beginning with the letter "J" or "E" (Electronic sensors and reed switches) are actuated by a magnetic band on the piston.
- Note 1:** Mid position "M" not available on EZ250 or EZ375 with prox options. "M" not available on any model with S50, S51, or S60.

Snap Action Mechanical Switches

Prewired style housing "S50"



Conduit fitting style housing "S51"

Air Pilot Switches "S60"

3-way air limit valve attached to mounting plate

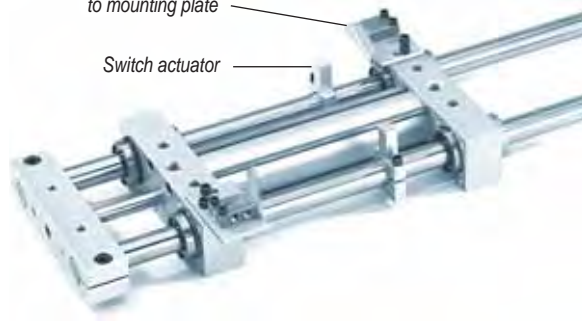

Switch actuator

Proximity Switch w/Brackets & Actuators

Prewired w/ 6' Leadwire	Quick Disconnect w/2 M cord set	Quick Disconnect without cord set	Thread Size	Electrical Characteristics
S01 <input type="checkbox"/>	S02 <input type="checkbox"/>	S12 <input type="checkbox"/>	12mm	110v AC, 2-wire, w/LED
S03 <input type="checkbox"/>	S04 <input type="checkbox"/>	S14 <input type="checkbox"/>	12mm	24v DC, 2-wire, w/LED (NPN/PNP)
S05 <input type="checkbox"/>	S06 <input type="checkbox"/>	S16 <input type="checkbox"/>	12mm	24v DC, 3-wire, w/LED (PNP) Sourcing
S07 <input type="checkbox"/>	S08 <input type="checkbox"/>	S18 <input type="checkbox"/>	12mm	24v DC, 3-wire, w/LED (NPN) Sinking

Proximity Switch Brackets & Actuators Only

S40 <input type="checkbox"/>	S45 <input type="checkbox"/>	See note 2	12mm	Customer supplies the switches
S41 <input type="checkbox"/>	S46 <input type="checkbox"/>	See note 2	8mm	Customer supplies the switches
S42 <input type="checkbox"/>	S47 <input type="checkbox"/>	See note 2	5mm	Customer supplies the switches

Snap Action Mechanical Switches

Prewired w/ 6' Leadwire	Conduit Fitting Style Housing	Electrical Characteristics
S50 <input type="checkbox"/>	S51 <input type="checkbox"/>	SPDT 10 amp. capacity (See note 3)

Air Pilot Switch

S60 <input type="checkbox"/>	Miniature 3-way air valve (See note 3)
------------------------------	--

Magnetic Piston & Clamp-On Sensors ("J")

Single sensor –1" stroke min; Dual sensors –2" stroke min. Not available on EZ250.

9 Ft. Prewired	Quick Disconnect w/5M cord set	Sensor Type	LED	Electrical Characteristics
J70 <input type="checkbox"/>	J71 <input type="checkbox"/>	Reed	Yes	5-120 VDC/VAC, 0.5 Amp Max, 10 Watt Max, SPST N.O., 3.5 Voltage Drop
J72 <input type="checkbox"/>	J73 <input type="checkbox"/>	Electronic	Yes	Sourcing PNP 6-24 VDC, 0.50 Amp Max, 1.0 Voltage Drop
J74 <input type="checkbox"/>	J75 <input type="checkbox"/>	Electronic	Yes	Sinking NPN 6-24 VDC, 0.50 Amp Max, 1.0 Voltage Drop

Magnetic Piston & Dovetail Style Sensors ("E")

For 1" Stroke & longer on all bores; Reed sensors not available on EZ250 or EZ375

9 Ft. Prewired	Quick Disconnect w/5M cord set	Sensor Type	LED	Electrical Characteristics
E70 <input type="checkbox"/>	E71 <input type="checkbox"/>	Reed	Yes	5-120 VDC/VAC, 0.03 Amp Max, 4 Watt Max, 2.0 Voltage Drop
E72 <input type="checkbox"/>	E73 <input type="checkbox"/>	Electronic	Yes	Sourcing PNP 6-24 VDC, 0.20 Amp Max, 0.5 Voltage Drop
E74 <input type="checkbox"/>	E75 <input type="checkbox"/>	Electronic	Yes	Sinking NPN 6-24 VDC, 0.20 Amp Max, 0.5 Voltage Drop
E76 <input type="checkbox"/>	E77 <input type="checkbox"/>	Reed	No	0-120 VDC/VAC, 0.5 Amp Max, 5 Watt Max, 0 Voltage Drop

Magnetic Piston

J800	Customer supplies the sensors and mounting clamps
E800	Includes Dovetail Mounting Rail; customer supplies the sensors

Note 2:

Codes S45, S46 and S47 are available on EZ500 & EZ625 models only. This is an alternative prox bracket location to accommodate the extra length of the quick disconnect cordset. See page 50 for details.

Note 3:

Not available on EZ250 or EZ375
Not available on EZ500 with MV1 or MV1B1 mounting styles
Not available on EZ625 with MV1B1 mounting style

Building the Model Number in 3 Easy Steps

Continue on to step 3
if you want to add
Tooling, Stop, or Shock
Options.

Prox Switches w/Brackets & Actuators

Prewired style
"S01, S03, S05, S07"

Switch actuator has
steel sensing flag

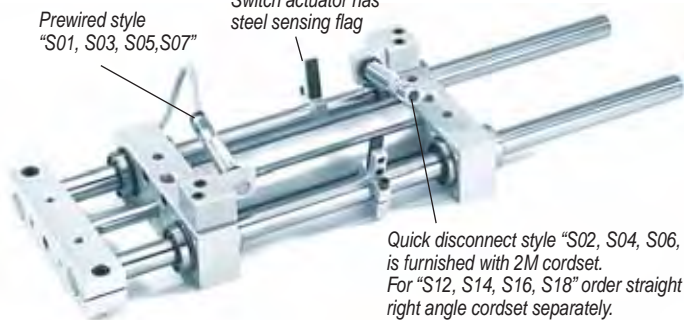

Quick disconnect style "S02, S04, S06, S08"
is furnished with 2M cordset.
For "S12, S14, S16, S18" order straight or
right angle cordset separately.

Female Cordsets w/2 Meter Leadwire for 12mm Proximity Switches

Option Code	Straight Cordset P/N	Rt. Angle Cordset P/N
S12	PCS01-2M	PCS02-2M
S14	PCS03-2M	PCS04-2M
S16	PCS05-2M	PCS06-2M
S18	PCS05-2M	PCS06-2M



4 meter and 6 meter cord
sets are also available.
Consult factory.

Clamp On Style Sensors "J70 - J75"

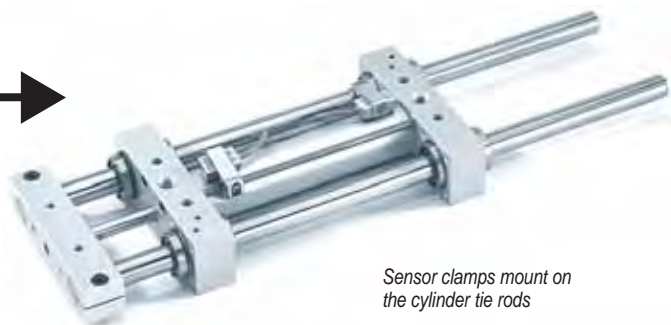

Sensor clamps mount on
the cylinder tie rods

Dovetail Style Sensors "E70 - E77"



Adhesive backed, double dovetail rail
bonds firmly to cylinder body; dovetail
sensors slide and lock into mating slots
in the rail.

“EZ” Series Linear Slides – Order Guide Continued

Step 3 Select a tooling option to adapt the slide to the application. Is stroke adjustability required? Select from four adjustable stop options. Are hydraulic shock absorbers needed? Standard mounting brackets are available for both Ace and Enidine. You can order complete shock assemblies – or brackets only if you are furnishing the shocks.

Step 3: Tooling, Stop, & Shock Options

To have a valid model number all (6) positions in this section must be filled in with a character.

— RC
01
AB
(Tooling Option)
(Stop Option)
(Shock Option)

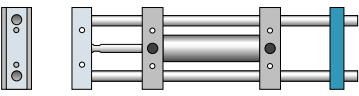
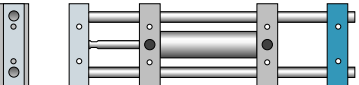
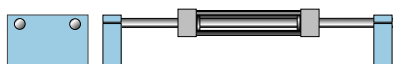
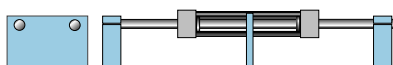
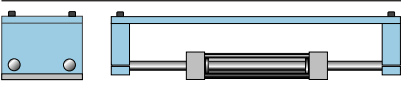
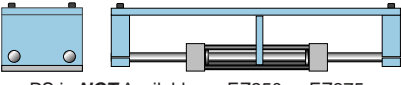
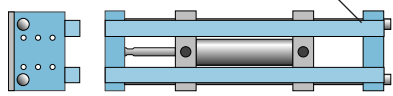
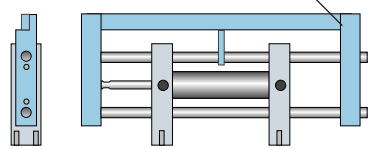
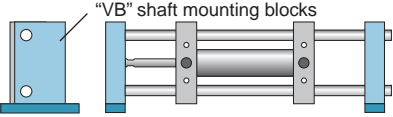
Select a Tooling Option	Stop Options	Shock Options
 <p>Code – RC Rear <u>C</u>l<u>a</u>m<u>p</u>bar</p>	01 U1 02	A <input type="checkbox"/> B <input type="checkbox"/> C <input type="checkbox"/>
 <p>Code – RT Rear <u>T</u>oolbar</p> <p>Note: Specifying “T1” blank toolbar in “Step 1” also designates a blank rear toolbar (– RT)</p>	01 U1	Extend shocks not available AR BR CR
 <p>Code – BL Tall <u>B</u>locks</p>	01 U1 02 03	A <input type="checkbox"/> B <input type="checkbox"/> C <input type="checkbox"/> D <input type="checkbox"/> E <input type="checkbox"/> F <input type="checkbox"/>
 <p>Code – CS w/center support</p> <p>CS is NOT Available on EZ250 or EZ375 S type sensors not available on EZ500/625/750</p>	01 U1 02 03	A <input type="checkbox"/> B <input type="checkbox"/> C <input type="checkbox"/> D <input type="checkbox"/> E <input type="checkbox"/> F <input type="checkbox"/>
 <p>Code – PL Tool<u>p</u>late</p>	01 U1 02 03	A <input type="checkbox"/> B <input type="checkbox"/> C <input type="checkbox"/> D <input type="checkbox"/> E <input type="checkbox"/> F <input type="checkbox"/>
 <p>Code – PS Toolplate & Ctr. <u>S</u>upport</p> <p>PS is NOT Available on EZ250 or EZ375 S type sensors not available on EZ500/625/750</p>	01 U1 02 03	A <input type="checkbox"/> B <input type="checkbox"/> C <input type="checkbox"/> D <input type="checkbox"/> E <input type="checkbox"/> F <input type="checkbox"/>
 <p>Code – TB Twin <u>B</u>eam</p> <p>*1018 CRS available at no additional cost</p> <p>TB is Available on EZ625 and larger models</p>	01 U1 02	A <input type="checkbox"/> B <input type="checkbox"/> C <input type="checkbox"/>
 <p>Code – SB Single <u>B</u>eam</p> <p>*1018 CRS available at no additional cost</p> <p>SB is Available on EZ625 and larger models. Not available with MF1, MF2, or MF3 endcaps</p>	01 U1 02	A <input type="checkbox"/> B <input type="checkbox"/> C <input type="checkbox"/>
 <p>Code – VB Vertical <u>S</u>haft <u>M</u>tg. <u>B</u>locks – VBB2</p> <p>w/mounting bars</p> <p>“VB” shaft mounting blocks “B2” mounting bars VB is only available with MH1 or MH2 endcaps</p>	03	D <input type="checkbox"/> E <input type="checkbox"/> F <input type="checkbox"/>

Completing Step 3 of the Model Number

General shock notes: 1) Shocks not available on EZ250 model.
 2) Shocks not available on EZ375-MF3
 3) 1/2" -20 thread shocks/brackets are used on EZ375, EZ500 & EZ625.
 4) 1" -12 thread shocks/brackets are used on EZ750, EZ1000 & EZ1500.

Adjustable Stop Option Details

The **Step 3 chart** on the opposite page indicates what stops are available for each tooling option. A tooling option must be selected before a stop option can be specified.

Code 00 – This code indicates no stops desired.

Code 01 –

Allows complete adjustment over the entire stroke length from full to zero stroke. Threaded rod (with two flange nuts serving as the stops) is fastened to cylinder endcap and passes thru a clearance hole in rear tooling.

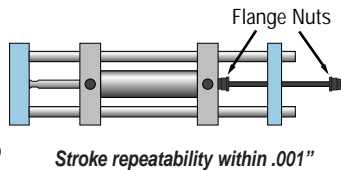

Code U1 –

Reduces noise and provides an impact absorbing stop cushion. It is the same stop as Type "01" with a urethane washer slipped onto the threaded rod against the flange nut.

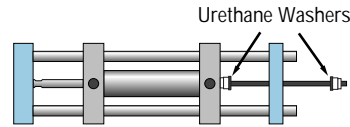

Advantage: Quiet operation
Note: Stopping accuracy is limited to approximately $\pm .025$ " because of the compressibility of the washer.

Code 02 –

Is a modification of Type "01" where a stop bolt is added for the extend stop. It positions both extend and retract adjustments next to each other at the back of the slide.

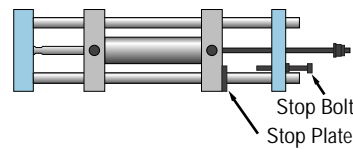

Provides easier, more accessible adjustment in cases where a tooling option would cover the extend flange nut in a Type "01" stop.

Code 03 –

Can only be used with "BL", "CS", "PL", "PS", or "VB" tooling options. Uses stop bolts at each end. On applications where the front & rear tall blocks are fixed and the cylinder is a reciprocating carriage, this "03" option eliminates the threaded stop rod which otherwise would also be reciprocating and require special guarding.

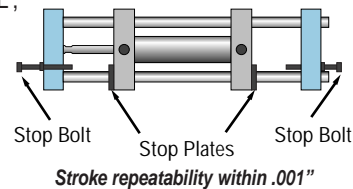

Shock Option Details

The **Step 3 chart** on the opposite page indicates what shocks are available for each tooling option. • **Indicate shock quantity/location in the box () as follows:**
 E = Extend only; R = Retract only; B = Both ext. & retract. Some shock options do not require a tooling option (EZ375 models, or "retract shock only"). Fill in Tooling/Stop option position with zeros if shocks are desired without tooling options. Example: EZ375-6.0-MH1-S000-0000BB

Code NO – Indicates no shocks

Standard Shock Location

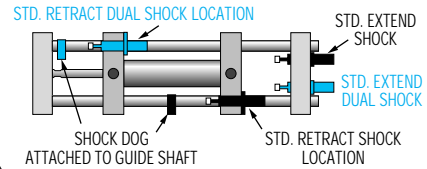

Standard Location

<input type="checkbox"/> AAce Shocks	<input type="checkbox"/> D
<input type="checkbox"/> BEnidine Shocks	<input type="checkbox"/> E
<input type="checkbox"/> CBrackets & Actuators only	<input type="checkbox"/> F

(Customer supplies the shocks)

Insert E, R or B in box

Alternate Location

Alternate Shock Location (Recommended when using "BL, CS, PL, PS, or VB" Tooling)

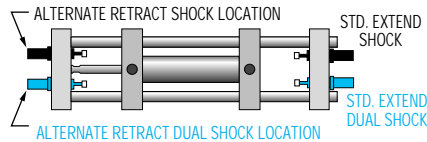

Note: EZ1500 models with Type "01" stop are available with a Dual Shock Option (2 extend and/or 2 retract shocks). Sensors S01 thru S60, when used with dual shocks are re-located. Both sensors are mounted to the front end cap.

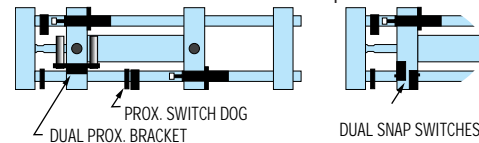

Standard Location

<input type="checkbox"/> AXAce Shocks	<input type="checkbox"/> DX
<input type="checkbox"/> BXEnidine Shocks	<input type="checkbox"/> EX
<input type="checkbox"/> CXBrackets & Actuators only	<input type="checkbox"/> FX

(Customer supplies the shocks)

Insert E, R or B in box

Alternate Location

"EZ" Series Linear Slides

MH Mounting Styles – MH1 (Thru Hole) – MH2 (Tapped Hole)

Top View

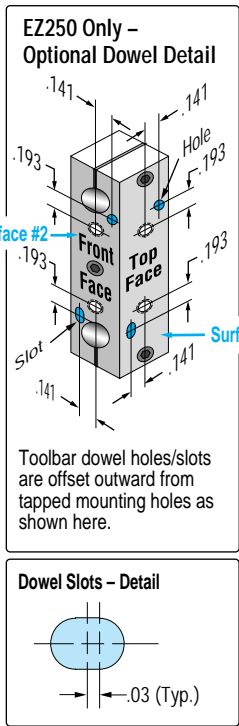
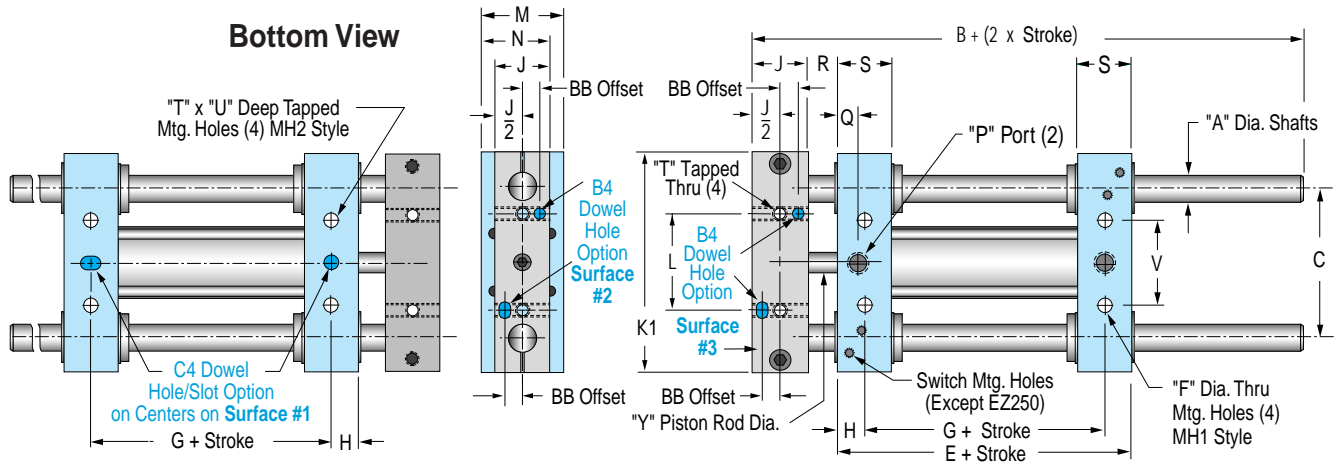

Ordering Examples:

- EZ500-4.0-MH1D12 Specifies dowel hole/slots on bottom mounting surface (#1) and toolbar face (#2)
- EZ500-4.0-MH1D3 Specifies dowel hole/slot on toolbar top (#3) only
- EZ500-4.0-MH2 Specifies tapped hole mounting with no dowel hole/slots

MF Mounting Styles – MF1 (Front Flange) – MF2 (Rear Flange) – MF3 (Front & Rear Flange)

Ordering Examples:

- EZ500-4.0-MF1 Specifies front flange mounting with no dowel hole/slots
- EZ500-4.0-MF2D26 Specifies rear flange with dowel hole/slot on toolbar face (#2) and end cap mounting surface (#6)

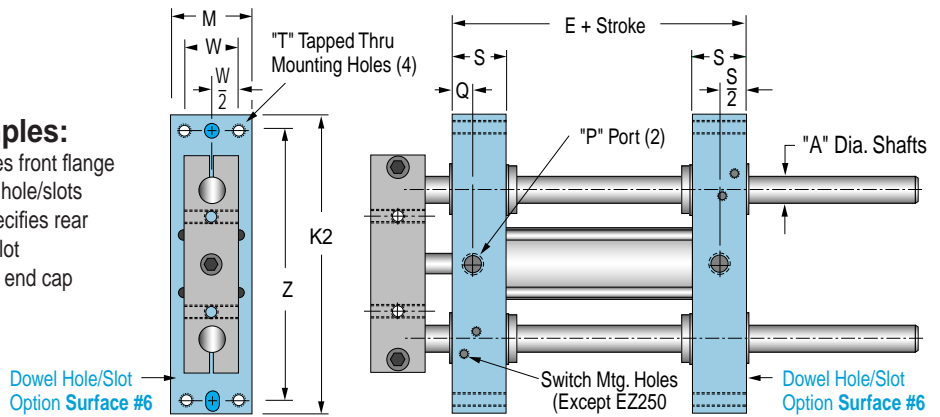

"EZ" Series Dimensional Data

Model	Bore	A	A1	B	B1	C	C1	D1	D2	E	E1	F	F1	G	H	J	K1	K2	K3
EZ250	1/2	1/4	.25	3.00	N/A	2.0000	1.75	N/A	N/A	1.25	N/A	.173	1.250	.75	.25	.50	2.75	3.75	3.38
EZ375	3/4	3/8	.38	4.50	2.25	2.0000	2.25	.968	.688	2.25	2.12	.204	1.750	1.50	.38	.75	3.00	4.12	3.75
EZ500	1-1/8	1/2	.50	6.12	2.50	2.7500	3.00	1.437	.688	2.75	2.69	.266	2.375	1.75	.50	1.00	4.00	5.50	5.00
EZ625	1-1/8	5/8	.50	6.12	2.50	3.2500	3.00	1.562	.688	2.75	2.88	.266	2.375	1.75	.50	1.00	4.75	6.25	5.75
EZ750	2	3/4	.75	8.50	3.38	4.5000	4.50	1.500	1.062	3.62	3.91	.406	3.500	2.38	.62	1.50	6.38	8.38	7.87
EZ1000	2-1/2	1	1.00	11.69	4.62	5.5000	6.00	2.062	1.062	5.12	5.19	.531	4.500	3.12	1.00	2.00	8.00	11.00	10.00
EZ1500	3-1/4	1-1/2	1.25	15.25	6.25	7.5000	8.00	3.062	1.187	7.25	6.38	.656	6.000	4.25	1.50	2.50	11.00	14.75	13.50

Mounting Style Dimensions

MV Side Tapped Mounting Styles

MV1 – (Ports as Shown)

MV2 – (Ports Opposite Side)

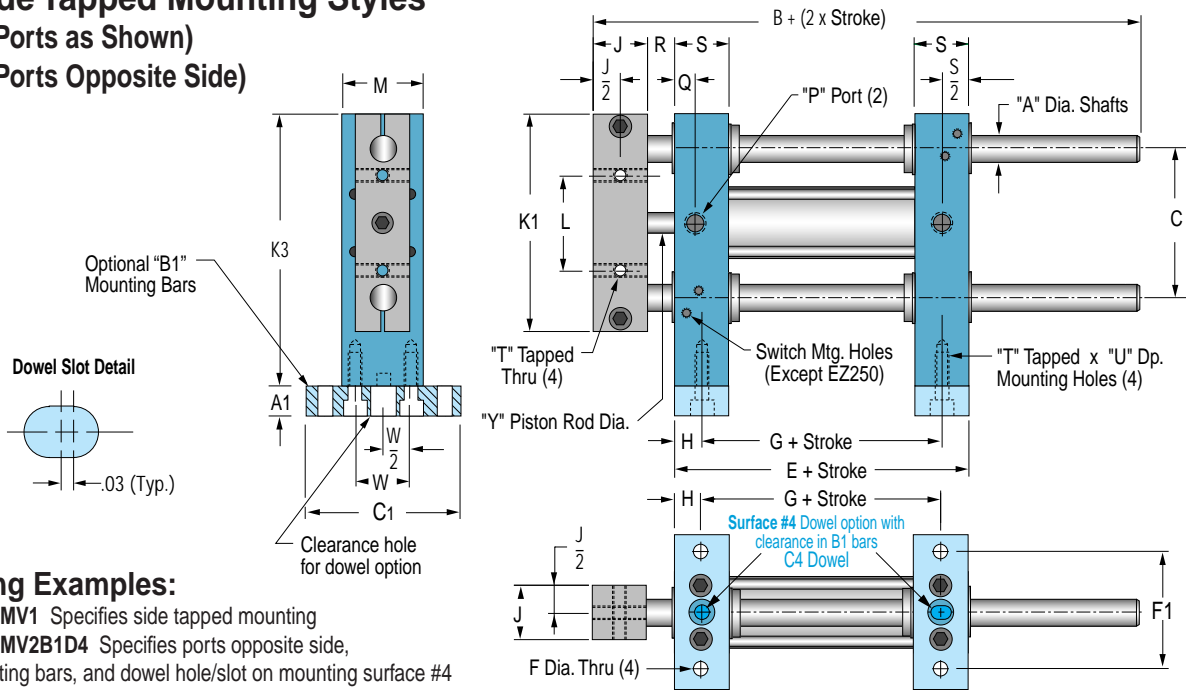

Ordering Examples:

EZ500-4.0-MV1 Specifies side tapped mounting

EZ500-4.0-MV2B1D4 Specifies ports opposite side, base mounting bars, and dowel hole/slot on mounting surface #4

FRBB – Floating Rear Bearing Block

MH1/MH2 Mounting Only



Notes:

- 1) Not available on EZ250 model
- 2) EZ1000 available with MH2 mounting only
- 3) Dowel Hole/Slot option in bearing block not available
- 4) Both bearing blocks must be fastened to a common baseplate to form a rigid assembly

Ordering Example:

EZ500-5.0-MH2-FRBB (D3.5)

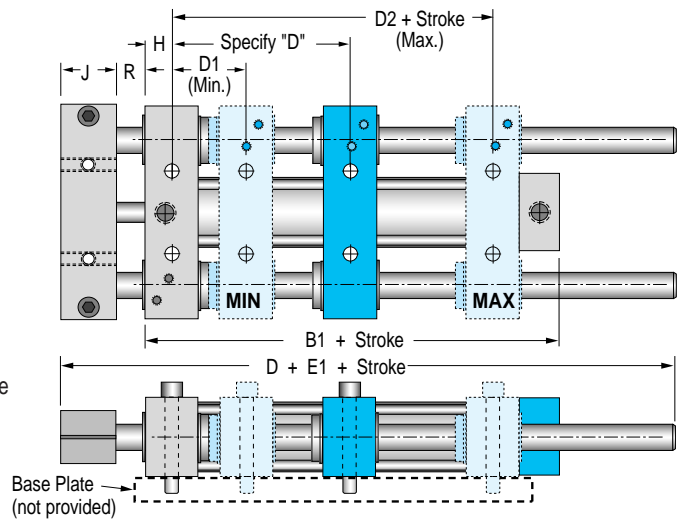

	L	M	N	P	Q	R	S	T	U	V	W	Y	Z	B4 Dowel Dimensions			C4 Dowel Dimensions	
														BB	Slip Fit for Dowel Size	Depth	Slip Fit for Dowel Size	Depth
	1.250	.75	.625	10-32	.25	.38	.50	8-32	.50	1.250	.437	.187	3.437	.141	3/32	.09	1/8	.15
	1.000	1.25	1.000	1/8 NPT	.40	.50	.75	10-24	.56	1.125	.875	.250	3.750	.250	1/8	.12	3/16	.18
	1.750	1.50	1.250	1/8 NPT	.38	.50	1.00	1/4-20	.75	1.562	1.000	.375	5.000	.313	3/16	.16	1/4	.25
	1.750	1.50	1.250	1/8 NPT	.38	.50	1.00	1/4-20	.75	1.750	1.000	.375	5.750	.313	3/16	.16	1/4	.25
	2.750	2.50	2.000	1/4 NPT	.50	.75	1.25	3/8-16	1.12	2.750	1.750	.625	7.625	.500	1/4	.25	3/8	.37
	3.250	3.00	2.500	1/4 NPT	1.00	.75	2.00	1/2-13	1.50	3.250	2.000	.750	10.000	.688	5/16	.37	3/8	.37
	4.250	4.00	3.250	3/8 NPT	1.50	.75	3.00	5/8-11	2.00	4.250	2.750	1.000	13.500	.875	3/8	.43	1/2	.50

“EZ” Series Linear Slides 3-Position Slides

EZ375 Tandem Cylinder Model

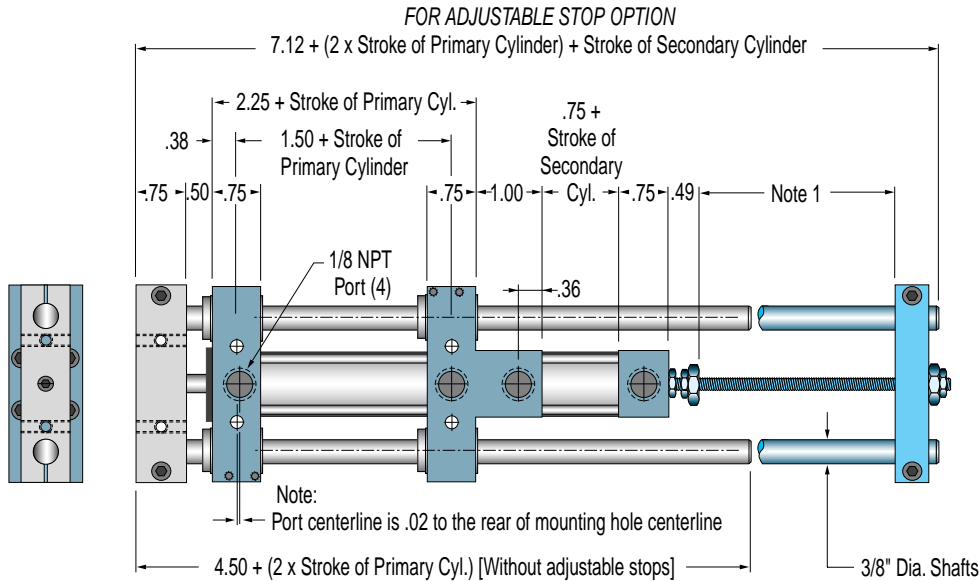

Note 1: Same as stroke of primary cylinder. (Adjustable stop package allows adjustment of end-of-stroke positions only. Mid-position is fixed.)

EZ500, EZ625, EZ750, EZ1000, EZ1500 Tandem Cylinder Models

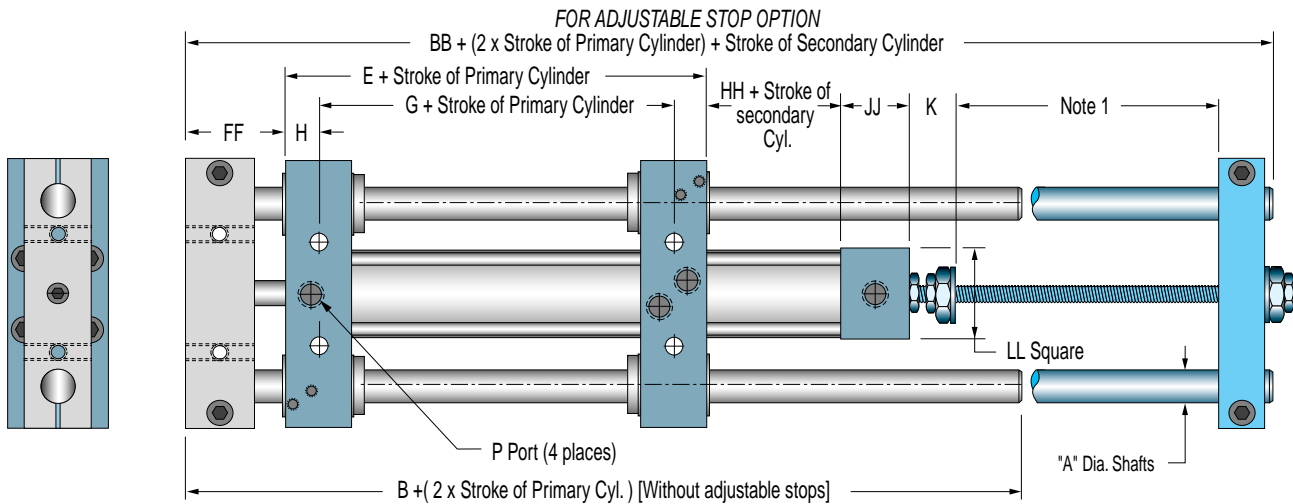

“EZ” 3-Position Tandem Cylinder Dimensional Data

Model	Bore	A	B	BB	E	FF	G	H	HH	JJ	K	LL	P
EZ500	1-1/8	1/2	6.12	7.50	2.75	1.50	1.750	.50	.75	1.00	.75	1.47	1/8 NPT
EZ625	1-1/8	5/8	6.12	7.50	2.75	1.50	1.750	.50	.75	1.00	.75	1.47	1/8 NPT
EZ750	2	3/4	8.50	10.62	3.62	2.25	2.375	.62	1.12	1.00	1.16	2.44	1/4 NPT
EZ1000	2-1/2	1	11.69	14.31	5.12	2.75	3.125	1.00	1.12	1.50	1.56	2.94	1/4 NPT
EZ1500	3-1/4	1-1/2	15.25	18.56	7.25	3.25	4.250	1.50	1.25	2.00	2.06	3.94	3/8 NPT

Two-axis motion where space is limited

"EZ" Series Thin Parts Placers

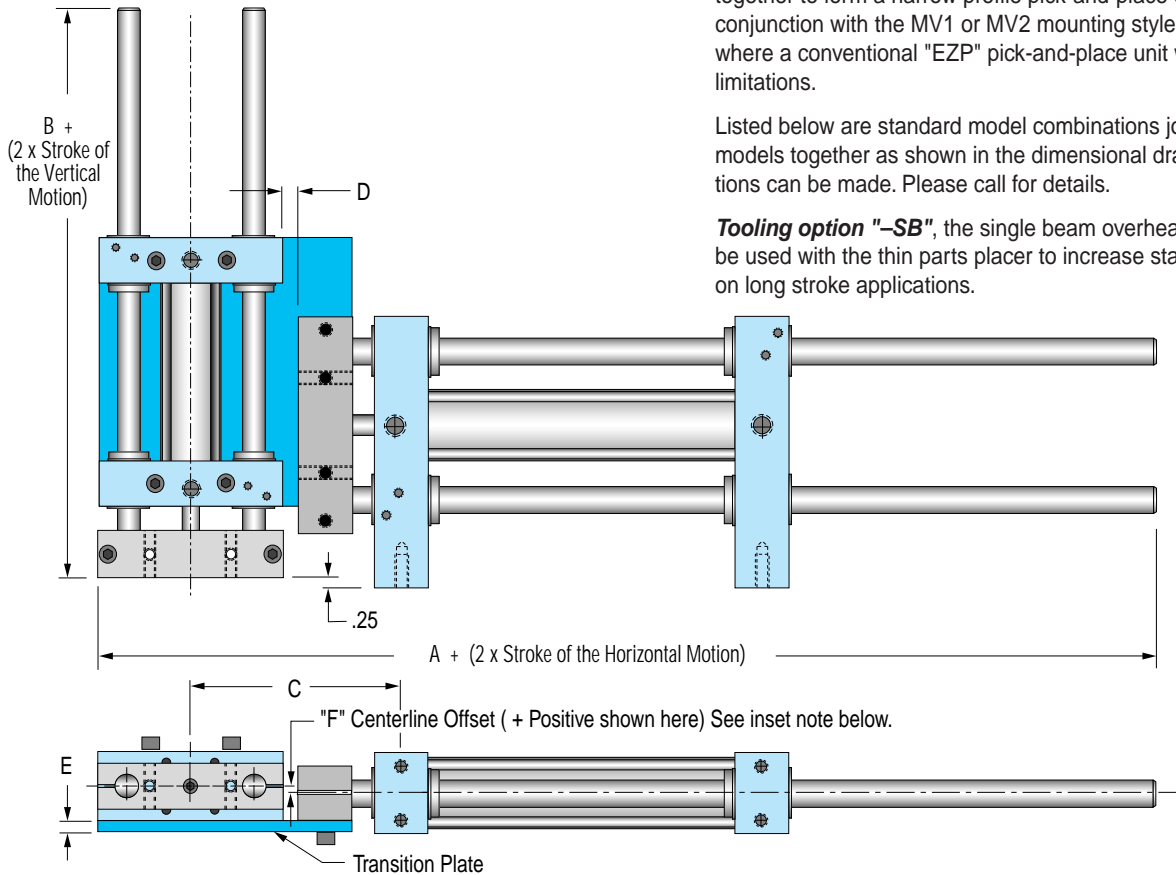

The thin parts placer uses a transition plate to join two "EZ" Series slides together to form a narrow profile pick-and-place unit. This option used in conjunction with the MV1 or MV2 mounting styles is ideal for applications where a conventional "EZP" pick-and-place unit will not fit tight space limitations.

Listed below are standard model combinations joining two standard "EZ" models together as shown in the dimensional drawing. Other combinations can be made. Please call for details.

Tooling option "-SB", the single beam overhead support option, can be used with the thin parts placer to increase stability and load capacity on long stroke applications.

How to Order:

Drawing and chart show transition plates used to join "EZ" Series slides to form a Thin Parts Placer. Order by designating the Plate Number for the combination desired, followed by a dash (-) and stroke length of the vertical motion slide.

Plate ordering example: TPL 38 / 25 - 4.0

Horiz. Slide Vert. Slide Vertical Slide
 EZ375 EZ250 Stroke Length

Note: Catalog number is for plate only. Order slides and their accessories separately.

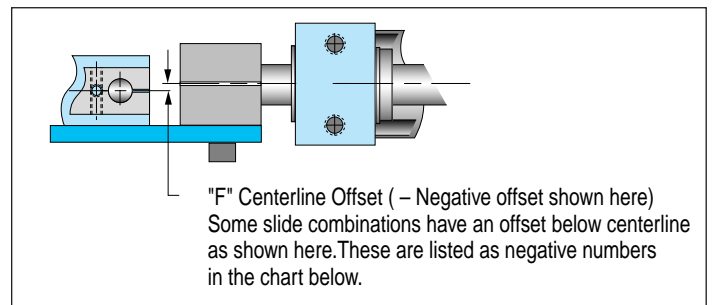

Transition Plates, Model Designations and Dimensions

Plate No.	38/25	50/25	50/38	62/25	62/38	62/50	75/38	75/50	75/62	100/50	100/62	100/75	150/75
Horizontal Motion Slide	EZ375	EZ500	EZ500	EZ625	EZ625	EZ625	EZ750	EZ750	EZ750	EZ1000	EZ1000	EZ1000	EZ1500
Vertical Motion Slide	EZ250	EZ250	EZ375	EZ250	EZ375	EZ500	EZ375	EZ500	EZ625	EZ500	EZ625	EZ750	EZ750
A	8.38	10.00	9.90	10.00	9.90	11.21	12.28	13.59	14.21	16.78	17.41	18.85	22.41
B	3.00	3.00	4.50	3.00	4.50	6.12	4.50	6.12	6.12	6.12	6.12	8.50	8.50
C	4.12	4.50	4.28	4.50	4.28	5.09	5.16	5.96	6.21	6.84	7.09	7.71	8.71
D	1.12	1.12	.78	1.12	.78	1.09	.78	1.09	.97	1.09	.97	.78	.78
E	.25	.25	.25	.25	.38	.38	.50	.50	.50	.50	.50	.75	.75
F	.00	-.13	.13	-.13	.13	.25	-.13	.00	.00	-.25	-.25	.25	.00

"EZ" Series Linear Slides

Proximity Switch for EZ250 Models

MH1 / MH2 Mounting Styles

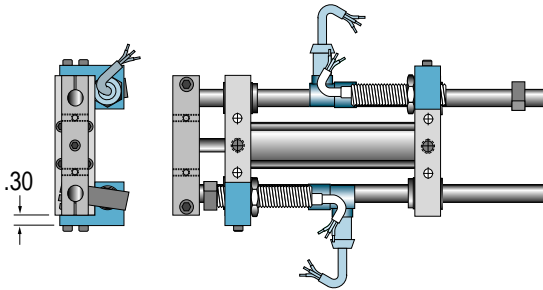

Note: For all EZ250 models
 -Right angle quick disconnect cordsets are provided with S02, S04, S06, S08 - and "M" mid-position prox is not available.

MF1 Mounting Style

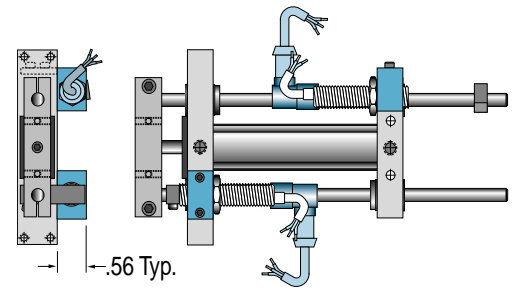

MV1 / MV2 Mounting Styles

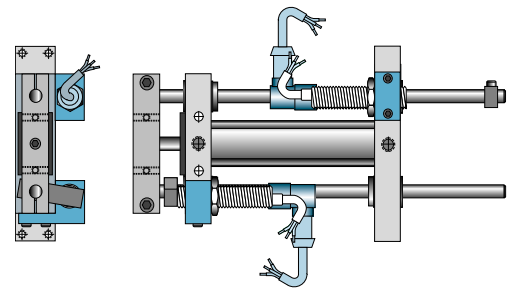
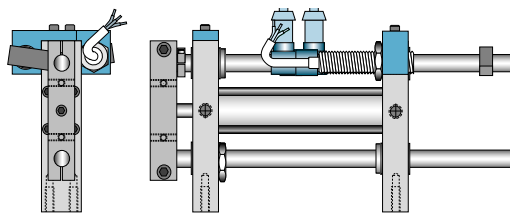

Proximity Switch for EZ375 Models

MH1 / MH2 / MV1 / MV2 / MF1 / MF2 / MF3 Mounting Styles

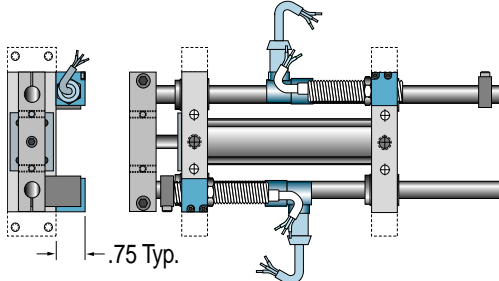

Note: For all EZ375 models
 -Right angle quick disconnect cordsets are provided with S02, S04, S06, S08 - and "M" mid-position prox is not available.

MF3 Mounting Style

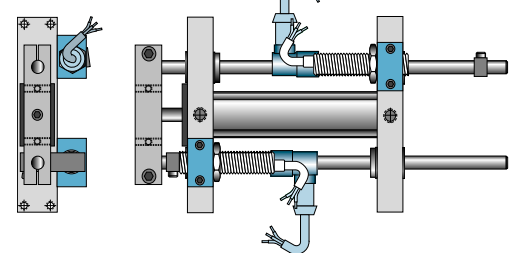

Proximity Switch for EZ500 & EZ625 Models

MH1 / MH2 / MV1 / MV2 / MF1 / MF2 / MF3 Mounting Styles

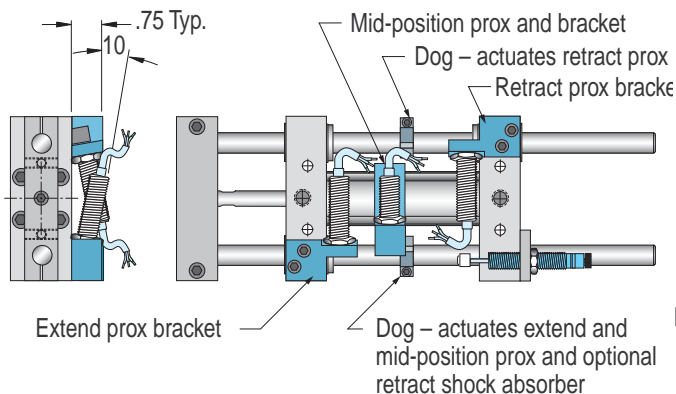

Pre-wired style
 (S01, S03, S05, S07, S40, S41, S42)

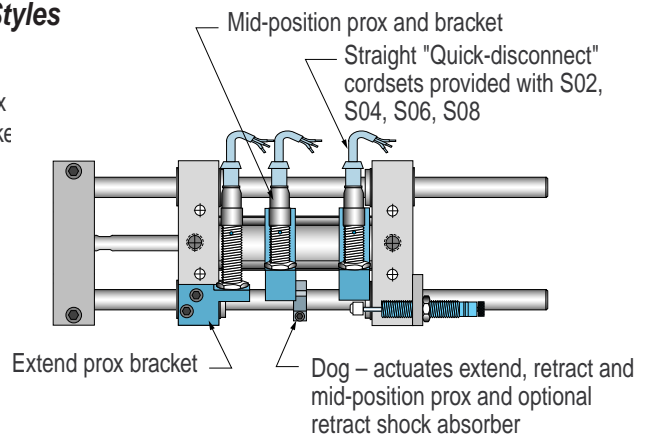

Quick disconnect style S02, S04, S06, S08, S12, S14, S16, S18, S45, S46, S47

Proximity Switch, Snap Action & Air Pilot Switch Options

Note: Proximity switches shown on these pages are 12mm. Options S01, S03, S05, S07 prewired style are supplied with 6 foot leadwire. Options S02, S04, S06, S08 quick disconnect style are supplied with 2 meter cordsets, in either straight or right angle depending on model size. Options S12, S14, S16, S18 are quick disconnect style without cordsets (order cordsets

separately from chart on page 43). Options S40, S41, S42 are prox brackets and actuators only (no switches). Options S45, S46, S47 are available on EZ500 and EZ625 models only, and provide brackets and actuators only (no switches) in an alternate location required to accommodate the longer cordsets of quick disconnect style prox switches.

Proximity Switch for EZ750, EZ1000 & EZ1500 Models

MH1 / MH2 / MV1 / MV2 / MF1 / MF2 / MF3 Mounting Styles

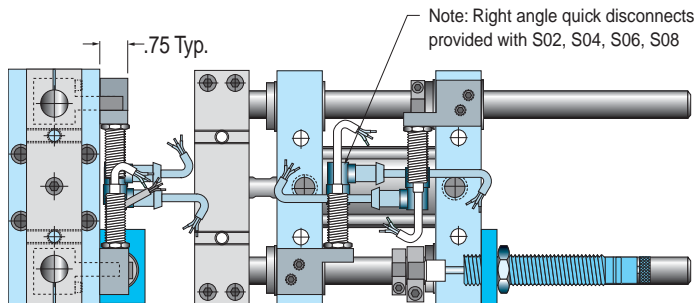

Standard prox switch locations for EZ750, EZ1000 and EZ1500

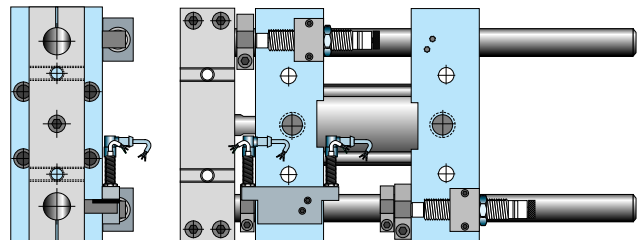

Prox switch locations for EZ1500 when dual shock absorbers are used

Snap Action Mechanical Switch for EZ500, EZ625, EZ750, EZ1000 & EZ1500

Note: Not available on EZ500 with MV1 mounting style
Not available on EZ625 with MV1B1 mounting style

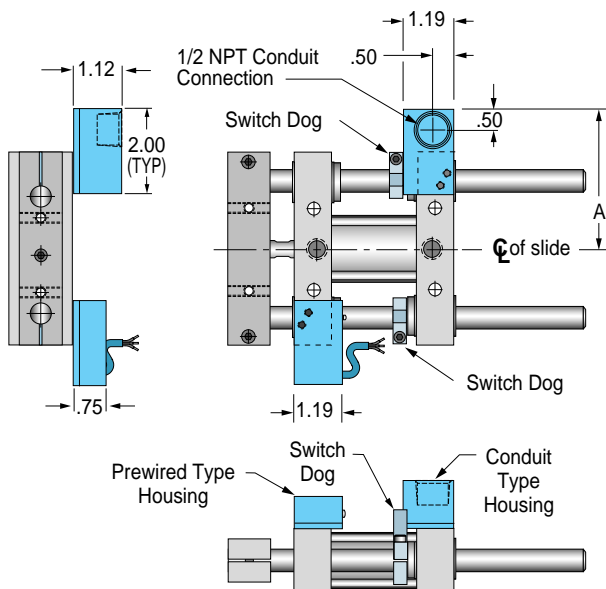

Air Pilot Switch for EZ500, EZ625, EZ750, EZ1000 & EZ1500

Note: Not available on EZ500 with MV1 mounting style
Not available on EZ625 with MV1B1 mounting style

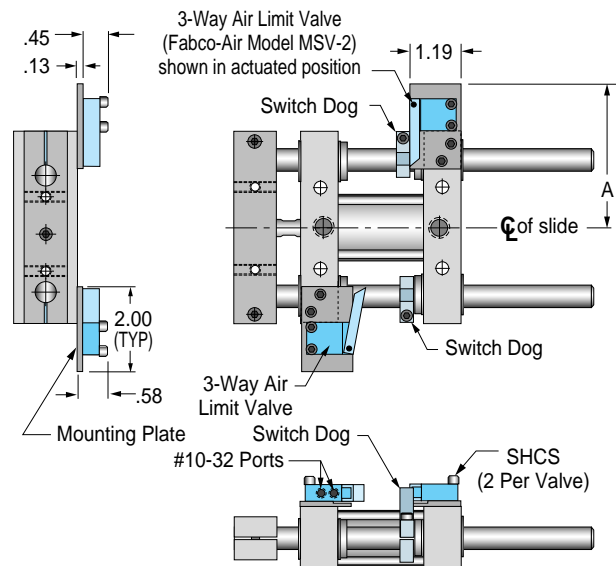

Snap Action & Air Pilot Switch Dimensions

Model	EZ500	EZ625	EZ750	EZ1000	EZ1500
A	3.06	3.31	3.94	4.44	5.50

"EZ" Series Linear Slides

Code "-RC" Rear Clamper for EZ250 Model

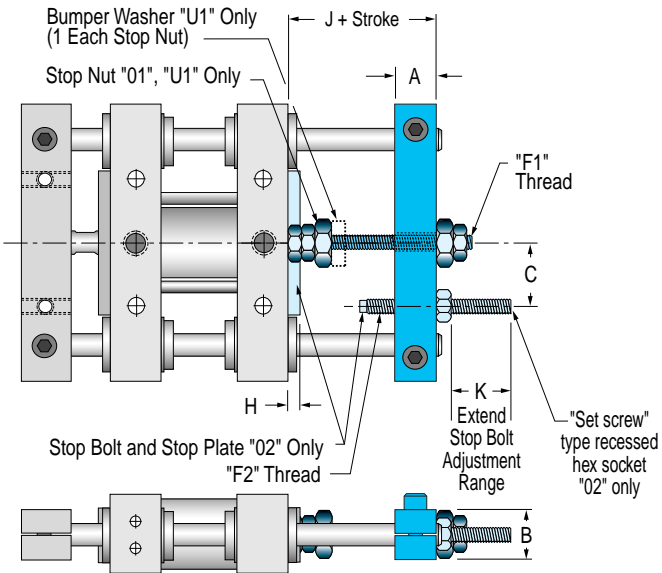

Code "-RC" Rear Clamper for EZ375 Model

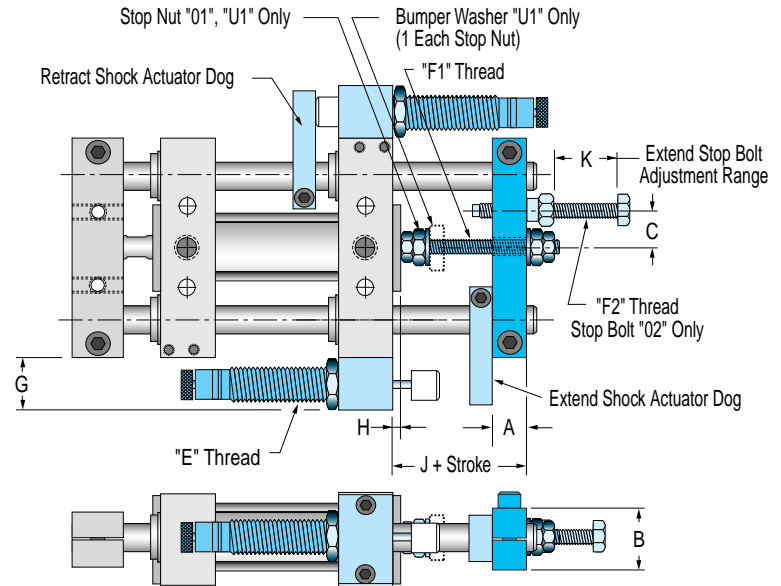

Code "-RC" Rear Clamper for EZ500, 625, 750 & 1000 Models

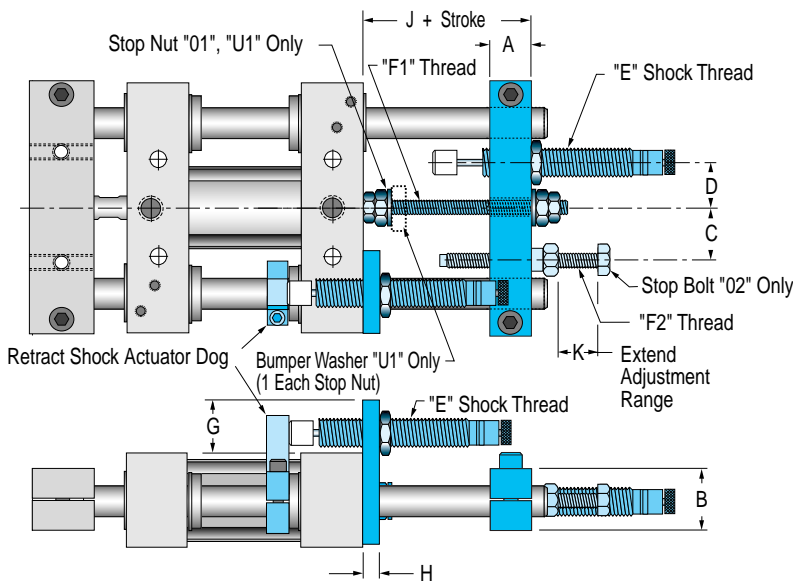

Code "-RC" Rear Clamper for EZ1500 Model

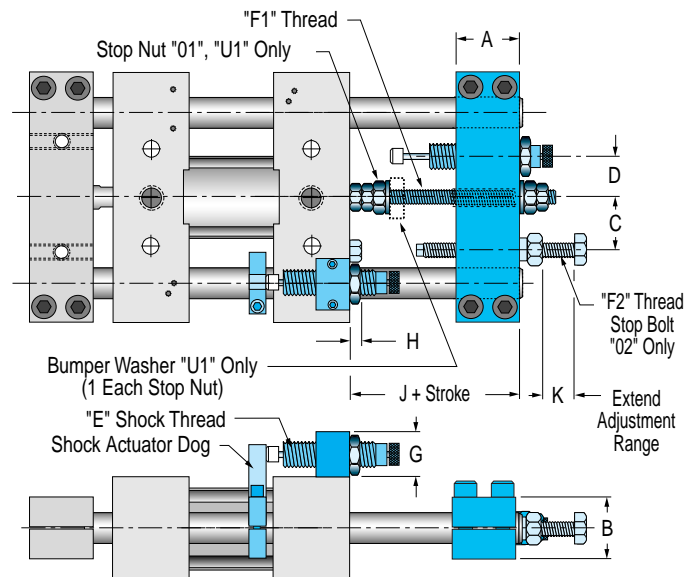

Model	A	B	C	D	E	F1	F2	G	H	J	JJ	K	L	M	N	NN
EZ250	.38	.50	.62	N/A	N/A	#10-24	#8-32	N/A	.13	.81	.94	.69	2.94	2.00	.25	1.250
EZ375	.50	.75	.53	N/A	1/2-20	#10-24	#10-24	.75	.13	.81	1.06	1.25	4.38	3.00	.31	1.000
EZ500	.62	1.00	.86	.72	1/2-20	1/4-20	1/4-20	.81	.25	1.12	1.94	1.25	5.88	4.00	.38	1.750
EZ625	.62	1.00	.88	.75	1/2-20	1/4-20	1/4-20	.81	.25	1.12	1.94	1.25	5.88	4.00	.38	1.750
EZ750	1.25	1.50	1.38	1.14	1.0-12	3/8-16	3/8-16	1.25	.38	2.44	2.69	1.31	8.25	5.00	.50	2.750
EZ1000	2.00	2.00	1.62	1.41	1.0-12	1/2-13	1/2-13	1.31	.50	3.56	3.88	1.03	11.44	6.00	.75	3.250
EZ1500	2.50	2.50	2.12	1.88	1.0-12	5/8-18	5/8-11	1.38	.50	4.50	4.81	1.22	15.00	6.00	1.00	4.250

Tooling, Stop and Shock Option Dimensions

Codes “-RT” Rear Toolbar (all models)

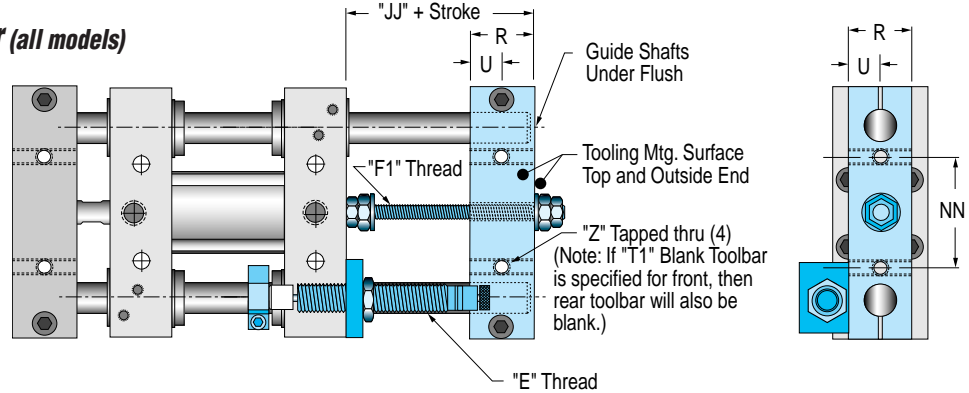

Codes “-BL, -CS, -PL & -PS”

“BL” Tall Blocks (all models)

“CS” Tall Blocks w/Center Support (note 1)

“PL” Toolplate (all models)

“PS” Toolplate & Center Support (note 1)

Note 1 –
Not available on EZ250
and EZ375 Models

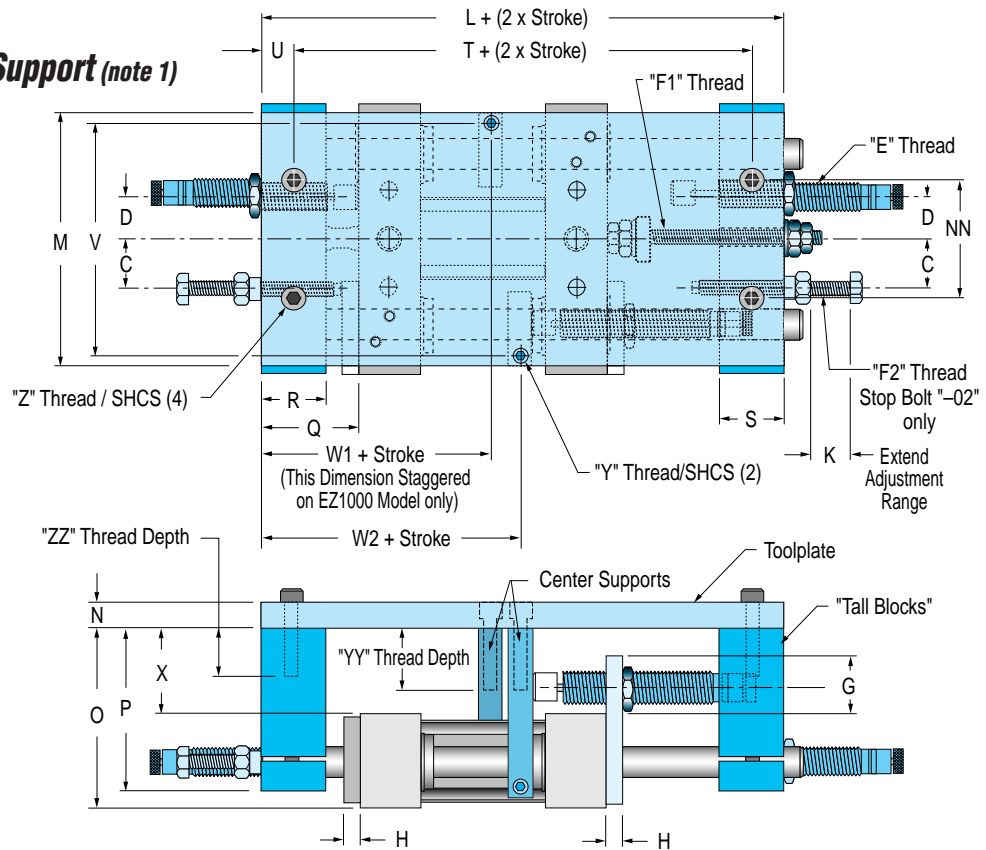

	O	P	Q	R	S	T	U	V	W1	W2	X	Y	YY	Z	ZZ	Model
	1.50	1.38	.88	.50	.38	2.50	.25	N/A	N/A	N/A	.75	N/A	N/A	#8-32	.38	EZ250
	2.25	2.00	1.25	.75	.50	3.75	.38	N/A	N/A	N/A	1.00	N/A	N/A	#10-24	.50	EZ375
	2.75	2.50	1.50	1.00	1.00	4.88	.50	3.25	2.88	2.88	1.25	#8-32	.31	1/4-20	.62	EZ500
	2.75	2.50	1.50	1.00	1.00	4.88	.50	3.25	2.88	2.88	1.25	#8-32	.38	1/4-20	.62	EZ625
	3.88	3.38	2.25	1.50	1.25	6.88	.75	4.25	4.06	4.06	1.38	1/4-20	.50	3/8-16	.75	EZ750
	4.50	4.00	2.75	2.00	2.00	9.44	1.00	5.25	5.05	5.59	1.50	5/16-18	.40	1/2-13	1.25	EZ1000
	5.75	5.00	3.25	2.50	2.50	12.50	1.25	7.75	6.88	6.88	1.75	3/8-16	.56	5/8-11	1.75	EZ1500

"EZ" Series Linear Slides

Code "-TB" Twin Beam (Available on EZ625 and larger models)

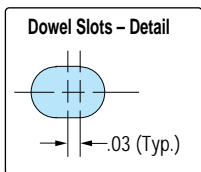
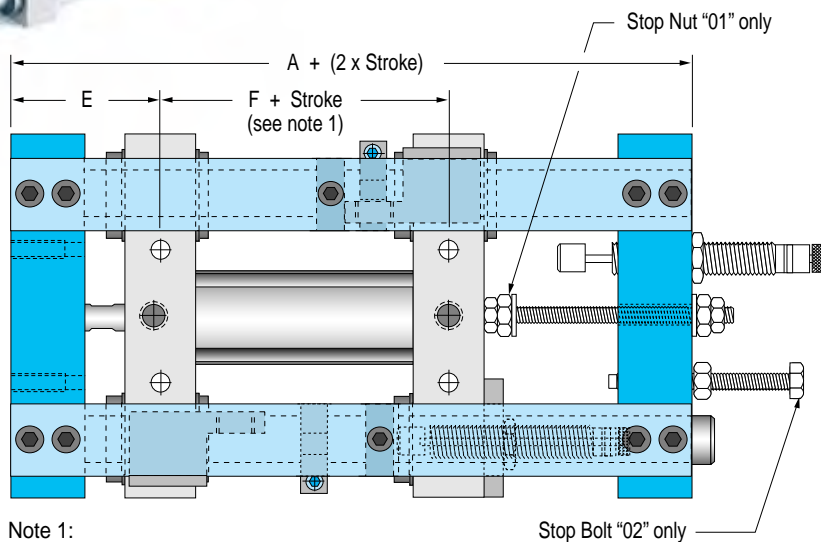

Note 1:
 On "EZ625" models only, this dimension is 1.0" longer than standard "EZ625" models without the "TB" option.

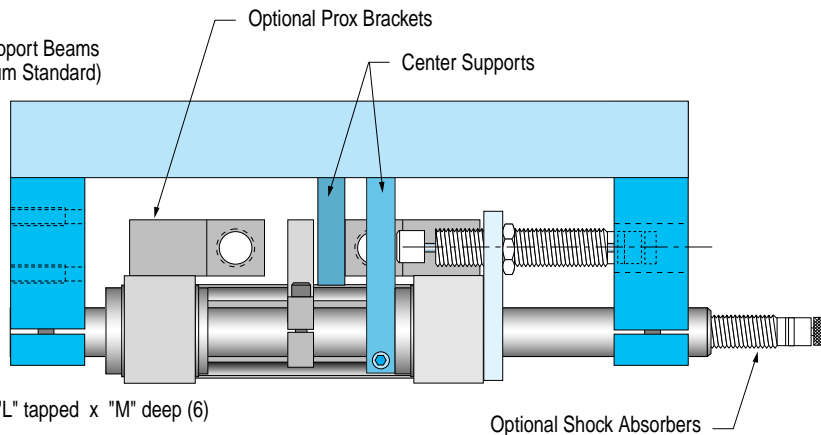
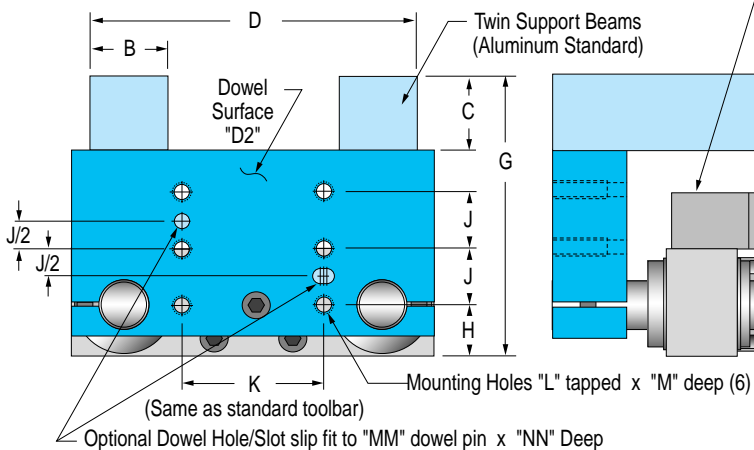

Model	A	B	C	D	E	F	G	H	J	K	L	M	MM	NN
EZ625	6.87	1.00	1.00	4.25	2.00	2.75	3.75	.75	.750	1.750	1/4-20	.75	3/16	.16
EZ750	8.31	1.00	1.25	6.09	2.88	2.38	5.12	1.25	1.000	2.750	3/8-16	1.00	1/4	.25
EZ1000	11.44	1.25	1.50	7.44	3.75	3.13	6.00	1.50	1.125	3.250	1/2-13	1.50	5/16	.37
EZ1500	15.00	1.50	2.00	10.13	4.75	4.25	7.75	2.00	1.375	4.250	5/8-11	1.50	3/8	.43

Tooling, Stop and Shock Option Dimensions

Code “-SB” Single Beam (Available on “EZ625” and larger models)



Here an EZ750 Model with a single beam (shown with MV1 mounting style, "02" adjustable stops, "B1" mounting bars, shock absorbers and proximity switches) is joined by a simple adapter plate to a vertical motion SE Series Slide to form a pick & place device.

An SPG 200, parallel jaw gripper is attached to the toolbar of the vertical motion slide.

Note 2: On EZ625 model only, this dimension is 1.0" longer than standard EZ625 without the “SB” option.

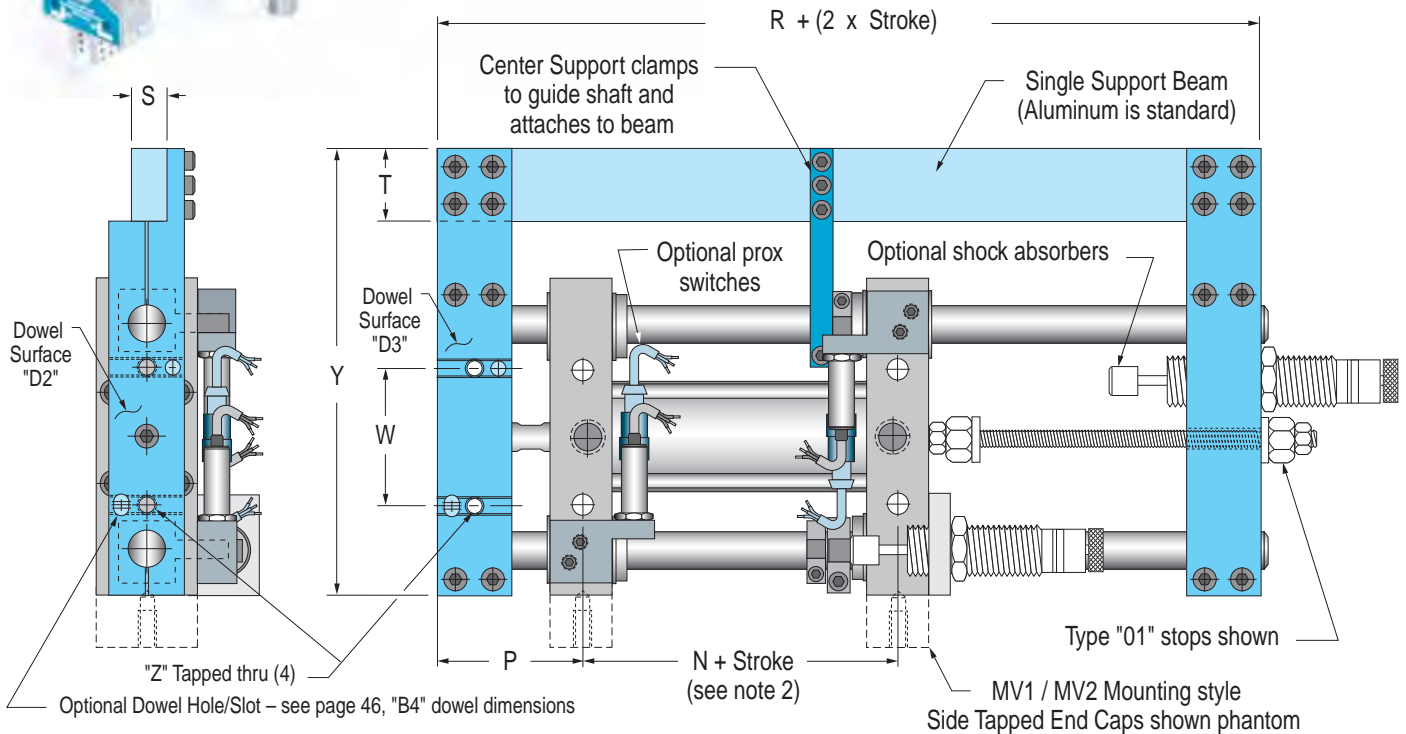

Model	N	P	R	S	T	W	Y	Z
EZ625	2.750	2.000	6.50	.500	1.500	1.750	6.50	1/4-20
EZ750	2.375	2.875	8.31	.750	1.500	2.750	9.00	3/8-16
EZ1000	3.125	3.750	11.44	1.000	2.000	3.250	11.00	1/2-13
EZ1500	4.250	4.750	15.00	1.250	2.500	4.250	14.12	5/8-11

"EZ" Series Linear Slides

Code "-VB" Vertical Shaft Mounting Blocks

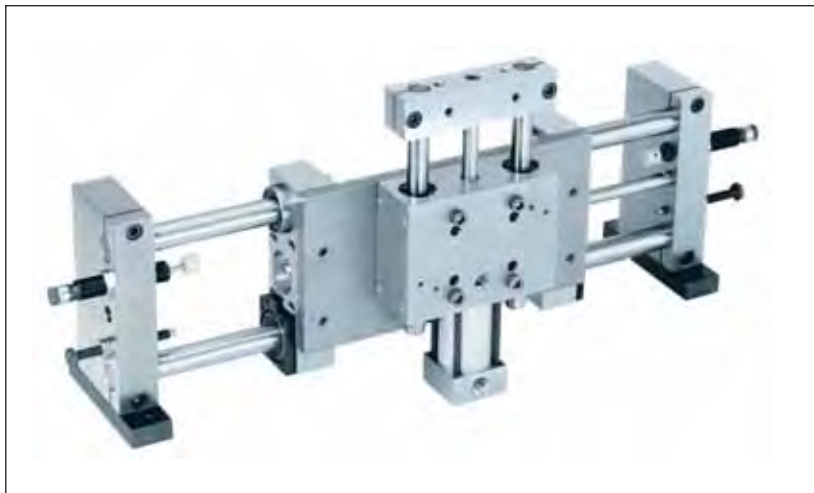

Here at the left an EZ625 Model with "VB" vertical mounting blocks (shown with "03" stop bolts, "B2" mounting bars, and shock absorbers) is joined by a simple adapter plate to a smaller SE Slide to form a two-axis motion device similar to the lift-and-carry mechanism shown on the opposite page.

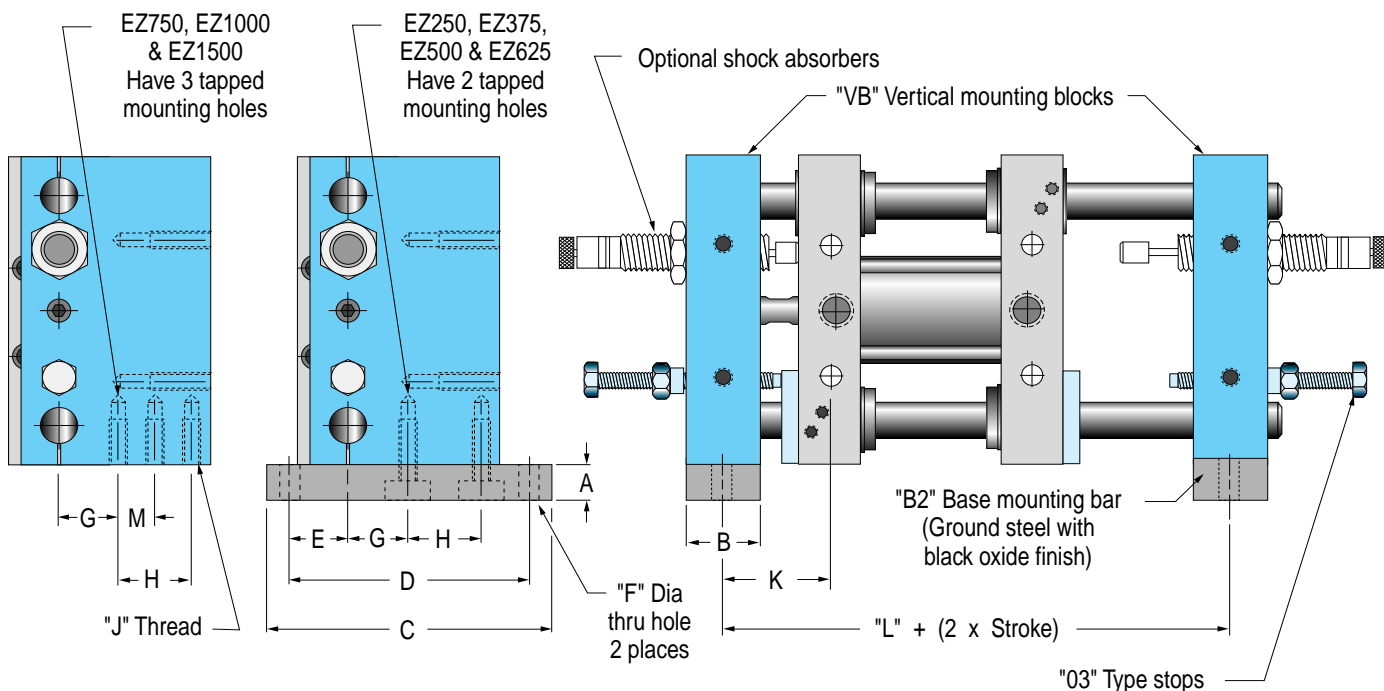

Model	A	B	C	D	E	F	G	H	J	K	L	M
EZ250	.38	.50	2.38	1.875	.500	.173	.406	.531	#8-32 x .38	.88	2.50	N/A
EZ375	.38	.75	3.00	2.500	.625	.204	.531	.812	#10-24 x .50	1.25	3.75	N/A
EZ500	.50	1.00	3.88	3.250	.875	.266	.750	1.000	1/4-20 x .62	1.50	4.88	N/A
EZ625	.50	1.00	3.88	3.250	.875	.266	.750	1.000	1/4-20 x .62	1.50	4.88	N/A
EZ750	.75	1.50	5.38	4.375	1.250	.406	.625	1.625	5/16-18 x .75	2.12	6.94	.812
EZ1000	1.00	2.00	7.50	6.000	2.000	.531	.750	1.875	3/8-16 x 1.00	2.75	9.44	.937
EZ1500	1.25	2.50	9.00	7.000	2.250	.656	1.250	2.000	1/2-13 x 1.25	3.50	12.50	1.000

Here are a few ways standard EZ Series Slides can be custom configured to precisely fit your application.

Two Slides on a Common Shaft

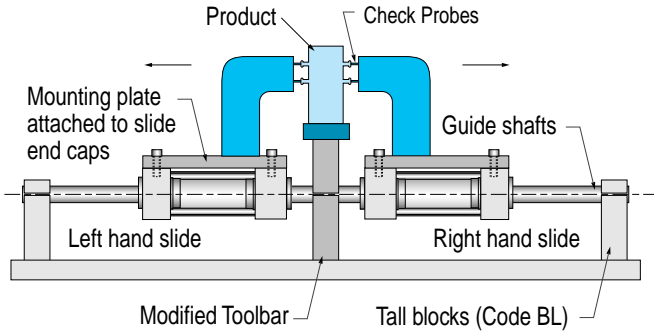

An electrical test is performed by bringing check probes in from both sides to contact the terminal screws on a transformer. A pair of guide shafts extend through a modified toolbar positioned in the center and supporting two individual slides. Both of the slide's piston rods are attached to the center toolbar. Depending on the transformer model tested, either the left or right (or both) sets of check probes can be activated to contact the product.

Lift and Carry Mechanism

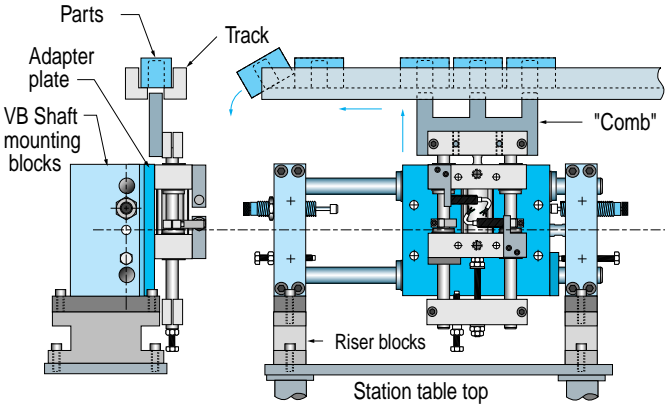

One EZ Series Slide joined by a simple adapter plate to a second, smaller EZ Slide forms a two-axis motion device that carries a "comb" which engages parts in an overhead feeder track. The parts are lifted slightly so that work can be performed on them (assembly, checking, ink branding, etc.). The horizontal motion shuttles the parts forward and pushes a part off the end of the track. Next the vertical unit retracts, lowering the "comb" while the horizontal unit returns ready to repeat the cycle.

Tandem Cylinder Pick & Place

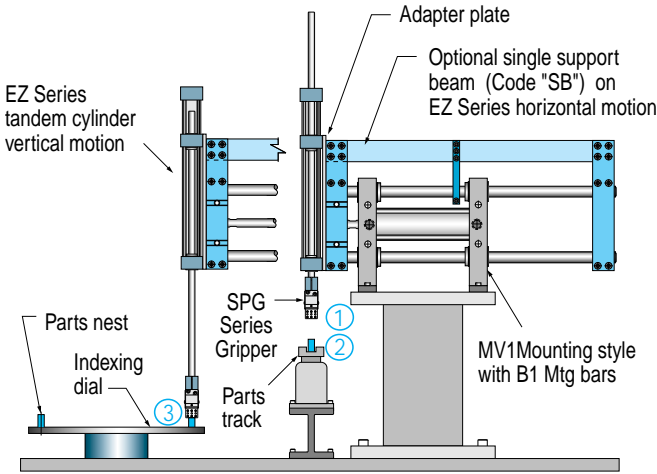

This pick & place application features a three-position tandem cylinder on the vertical motion allowing the track fed parts to be picked up at one level and placed into the nest on the dial at a lower level. ① is retract position for tandem cylinder; ② is mid position; ③ is extend position.

Pallet Lift Station

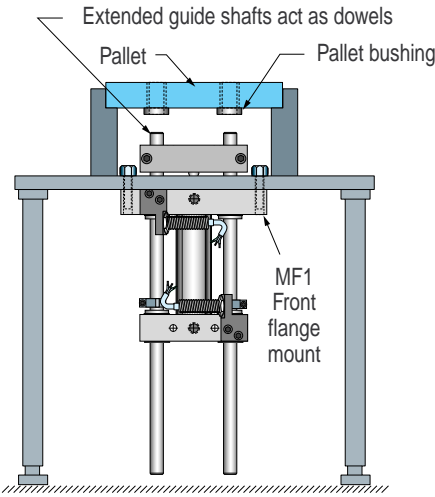

An EZ Series Slide with front flange mounting (MF1) used as a pallet lift mechanism on a conveyor type assembly system. Extra length guide shafts extend through the slide's toolbar and act as locating dowels that engage pallet bushings to provide precise pallet positioning.

“EZ” Series Linear Slides

Step 1

EZ750 – 5.0 –MV1 B1 T1 – VZX

Indicate
“EZ” series.

Select model size
based on guide
shaft dia.

Model Size	Guide Shaft Diameter	Bore
250	1/4"	1/2"
375	3/8"	3/4"
500	1/2"	1-1/8"
625	5/8"	1-1/8"
750	3/4"	2"
1000	1"	2-1/2"
1500	1-1/2"	3-1/4"

Select a stroke
(Special strokes
also available)

Select
Integral
Options

Mounting Styles

- MH1** = Thru Hole Mounting
- MH2** = Tapped Hole Mounting
- MF1** = Front Flange Mounting
- MF2** = Rear Flange Mounting
- MF3** = Front & Rear Flange Mounting
- MV1** = Side Tapped Mounting Holes
- MV2** = Side Tapped with Ports on Opposite Sides
- MV1B1** = Side Tapped Mounting Holes with Base Mounting Bars (1 Pair)
- MV2B1** = Side Tapped Mounting Holes with Ports on Opposite Sides and Base Mounting Bars (1 Pair)

Integral Options

- D** – Dowel Hole and Slot
Specify Surface Location(s)
1, 2, 3, 4, or 6 in box(es)
- H** – Hydraulic Cylinder Seals
- V** – Viton Cylinder Seals
- Bearing Options**
- W** – Rulon® Sleeve Bearings
- X** – Duralon® Sleeve Bearings
- Guide Shaft Options**
- Y** – Hollow Guide Shafts
- Z** – Stainless Steel Guide Shafts

Model Standard Stroke Length

EZ250	1/2" to 4" by 1/2" increments
EZ375	1" to 6" by 1" increments
EZ500	1" to 10" by 1" increments
EZ625	1" to 10" by 1" increments
EZ750	1" to 6" by 1" increments 8" to 18" by 2" increments
EZ1000	1" to 6" by 1" increments 8" to 20" by 2" increments
EZ1500	2" to 30" by 2" increments

Toolbars

- **T1** = Blank Toolbar
- **T2** = Toolbar for Model EZ375 to attach an EZ375
- **T3** = Toolbar for Model EZ500 to attach an SE500 or an EZ500
- **T4** = Toolbar for Model EZ1000 to attach an SE500, EZ500, SE750 or EZ750

Step 2

– S03B

Sensor Options

Sensor Options

S000 – Indicates **NO SENSORS** desired

Note: Indicate sensor location in the box ().

E= Extend, R=Retract, B=Both Extend & Retract, M=3 Sensors

S01 through S18

12mm Prox Switch w/Brackets & Actuators
– Choose desired electrical characteristics
– Choose pre-wired or quick disconnect with or without cord set

S40 through S47

Prox Switch Brackets & Actuators Only, no Switches. – Choose 12mm, 8mm, or 5mm

S50, S51 (E, R, or B only)

Snap Action Mechanical Switches
– Choose pre-wired or with conduit fitting

S60 (E, R, or B only)

Air Pilot Switch

J70 through J75 (Not available on EZ250)

Magnetic Piston and Clamp-on Sensors.

– Choose reed or electronic (PNP or NPN)
– Choose pre-wired or quick disconnect with cordset

Single sensor – 1" stroke min.

Dual sensors – 2" stroke min.

J800

Magnetic Piston Only, No Sensors

E70 through E77

Magnetic Piston & Dovetail Style Sensors

– Choose reed or electronic (PNP or NPN)
– Choose prewired or quick disconnect with cordset.

Requires 1" or longer stroke. Reed switches not available on EZ250 or EZ375.

E800

Magnetic Piston & Dovetail Mounting Rail (attached) only, no sensors. Requires 1" or longer stroke

Step 3

–RC 01 AB

Select Tooling Options

Tooling Options

RC – Rear Clampbar
RT – Rear Toolbar
BL – Tall Blocks
CS – Tall Blocks w/Center Support
PL – Toolplate
PS – Toolplate with Center Support
TB – Twin Beam
SB – Single Beam
VB – Vertical Shaft Mounting Blocks
VBB2 – Vertical Shaft Mounting Blocks w/Mounting Bars

Select Stop Option

Stop Options

00 – No stops desired
01 – Threaded Rod with Flange Nuts
U1 – 01 Stop with Urethane Washers
02 – Threaded Rod with Retract Flange Nut and an Extend Stop Bolt
03 – Extend and Retract Stop Bolts

Select Shock Option

Shock Options

N0 – Indicates **NO SHOCKS** desired

Specify E, R, or B in box ().

A – Ace Shocks
B – Enidine Shocks
C – Brackets and actuators only

Alternate Location

D – Ace Shocks
E – Enidine Shocks
F – Brackets and actuators only

Dual Shock Options for Model EZ1500 only

AX – Ace Shocks
BX – Enidine Shocks
CX – Brackets and actuators only

Alternate Location

DX – Ace Shocks
EX – Enidine Shocks
FX – Brackets and actuators only

“EZP” Series Pick & Place Units

EZP5025

Cylinder Endcaps
Clear anodized aluminum with precision machined mounting surface

Choice of endcap mounting styles
Code – MH1: Thru-hole mounting (shown)
Code – MH2: Bottom tapped mounting hole
Code – MF1/MF2/MF3: Flange mount styles
Code – MV1/MV2: Side tapped hole mounting

Optional Dowel Hole/Slot

Code –D

Optional slip fit dowel holes and slip fit dowel slots allow for repeatably precise slide mounting and/or attachment of end tooling. Option may be specified at any of the four surface locations (1, 2, 4 or 6) listed here.

- #1 – MH1/MH2 end cap mounting surface (bottom mounting surface)
- #2 – Toolbar bottom
- #4 – MV1/MV2 end cap mounting surface (side mounting surface)
- #6 – MF1/MF2/MF3 end cap mounting surface (flange face)

Std. Strokes
1" – 5"

VERTICAL MOTION
Compact “TS” Style slide (shown with “V04” adjustable downstop)

HORIZONTAL MOTION

Same component parts as an EZ500 slide. (shown with “H01” adjustable stops)

Toolbar

Clear anodized aluminum, machined bottom & front for squareness. Bottom mounting surface features 4 tapped mounting holes, plus c’bores at top for thru hole mounting. Front face has 2 tapped mounting holes. Optional slip fit dowel hole and slot (bottom surface only) assure repeatably precise tooling attachments. Code – T1: Optional blank toolbar (no mounting holes)

Note:
Each axis is designated horizontal or vertical as shown. However, unit can be mounted in any attitude required by your application

Engineering Data

EZP5025 Specifications		
	Horizontal	Vertical
Guide Shaft Diameter	1/2"	1/4"
Bore	1-1/8"	1-1/8"
Power Factor Extend	.99	.90
Power Factor Retract	.88	.90
Standard Strokes (Specials available)	1" thru 10" by 1" incr.	1" thru 5" by 1" incr.
Ship weight, lbs. Zero stroke	3.62	
Add per inch of stroke	.32	.12

		SAFE LOADS (lbs.)									
Vertical Stroke	5	1.0	1.0	1.0	1.0	1.0	1.0	1.0	1.0	1.0	1.0
	4	1.6	1.6	1.6	1.6	1.6	1.6	1.6	1.6	1.6	1.4
3	3.8	3.8	3.8	3.8	3.8	3.8	3.8	3.0	1.8	1.4	
2	8.7	8.7	8.7	8.7	8.0	6.0	4.0	3.0	1.8	1.4	
1	9.9	9.9	9.9	9.9	8.0	6.0	4.0	3.0	1.8	1.4	
		1	2	3	4	5	6	7	8	9	10
		Horizontal Stroke									

Max Operating Pressure: 150 psi

Output Force:

Pounds = Pressure x Power Factor

Speed: Speeds up to 24 inches per second are obtainable by utilizing an optional stop package in conjunction with urethane bumpers or hydraulic shocks. Moderate reciprocating loads can be safely cycled up to 12 inches per second by utilizing an adjustable stop option without bumpers or shocks. Except for light loads and moderate speeds, operating EZP Pick & Place units without an adjustable stop option is **not** recommended. Moderate to heavy loads should **not** be stopped by bottoming the piston against the end cap.

Important note: Most failures are caused by severe, damaging impact loads (which act like a



Load Sizing

built tough with the most advanced features and options

EZP7550

Optional Dowel Hole/Slot Code -D

Optional slip fit dowel holes and slip fit dowel slots allow for repeatably precise slide mounting and/or attachment of end tooling. Option may be specified at any of the five surface locations (1, 2, 3, 4 or 6) listed here.

#1 - MH1/MH2 end cap mounting surface (bottom mounting surface)

#2 - Toolbar bottom

#3 - Toolbar front face

#4 - MV1/MV2 end cap mounting surface (side mounting surface)

#6 - MF1/MF2/MF3 end cap mounting surface (flange face)

Std. Strokes
1" - 10"

VERTICAL MOTION

Same component parts as an EZ500 slide. (shown with "V01" adjustable stops)

Toolbar

Clear anodized aluminum, machined bottom and front for squareness. Bottom mounting surface has 2 tapped mounting holes. Front face has 2 tapped mounting holes. Optional slip fit dowel hole and slot (available on front and/or bottom mounting surfaces) assure repeatably precise tooling attachments. Code - T1: Optional blank toolbar (no mtg holes)

Cylinder Endcaps

Clear anodized aluminum with precision machined mounting surface

Choice of endcap mounting styles

Code - MH1: Thru-hole mounting (shown)

Code - MH2: Bottom tapped mounting hole

Code - MF1/MF2/MF3: Flange mount styles

Code - MV1/MV2: Side tapped hole mounting

"H01"
Adjustable stops

Standard Strokes 1" - 18"

HORIZONTAL MOTION

Same component parts as an EZ750 slide. (shown with "H01" adjustable stops)

"slide hammer" on the piston rod). Proper model sizing, use of adjustable stops and/or shocks/bumpers, and operating the unit at the lowest possible air pressure will insure successful operation and long product life.

Accuracy: EZP Pick & Place units feature linear ball bearings for near play free operation. Each bearing has .0005" max "play" or less. The built-in air cylinder will stroke $\pm .015"$ / $-.000"$ of nominal stroke. Stroke repeatability is $\pm .001"$. Guide shaft straightness tolerance is .0015" per foot of shaft.

Bearings in the EZP Pick & Place units are housed in the cylinder end caps. As the stroke increases, the pairs of bearings become spaced further apart, increasing bearing load capacity.

Guides



EZP7550 Specifications		
	Horizontal	Vertical
Guide Shaft Diameter	3/4"	1/2"
Bore	2"	1-1/8"
Power Factor Extend	3.14	.99
Power Factor Retract	2.84	.88
Standard Strokes (Specials available)	1" to 6" by 1" 8" to 18" by 2"	1" thru 10" by 1" incr.
Ship weight, lbs. Zero stroke	9.98	
Add per inch of stroke	.74	.32

		SAFE LOADS (lbs.)											
Vertical Stroke	10	1.4	1.4	1.4	1.4	1.4	1.4	1.4	1.4	1.4	1.4	1.4	1.4
	9	1.8	1.8	1.8	1.8	1.8	1.8	1.8	1.8	1.8	1.8	1.8	1.8
8	3.0	3.0	3.0	3.0	3.0	3.0	3.0	3.0	3.0	3.0	3.0	2.2	1.8
7	4.0	4.0	4.0	4.0	4.0	4.0	4.0	4.0	4.0	4.0	4.0	2.2	1.8
6	6.0	6.0	6.0	6.0	6.0	6.0	6.0	6.0	6.0	5.0	4.0	2.2	1.8
5	8.0	8.0	8.0	8.0	8.0	8.0	8.0	8.0	8.0	5.0	4.0	2.2	1.8
4	12.0	12.0	12.0	12.0	12.0	12.0	12.0	8.0	5.0	4.0	2.2	1.8	
3	24.0	24.0	24.0	24.0	24.0	20.0	12.0	8.0	5.0	4.0	2.2	1.8	
2	44.0	44.0	44.0	44.0	28.0	20.0	12.0	8.0	5.0	4.0	2.2	1.8	
1	84.0	84.0	60.0	56.0	28.0	20.0	12.0	8.0	5.0	4.0	2.2	1.8	
		1	2	3	4	5	6	8	10	12	14	16	18
		Horizontal Stroke											

“EZP” Series Pick & Place Units – Order Guide

Step 1 Select a pick-and-place model size, horizontal & vertical stroke lengths, horizontal endcap mounting style, plus any optional toolbar, mounting bar (B1) or integral option (such as Viton seals, etc.) Helpful hint: **The first two digits in the part number = the guide shaft diameter of the horizontal motion to two places; the second pair = the guide shaft diameter of the vertical motion to two places.**

Step 1: Basic Pick & Place Model

EZP7550 – **5H** **2V** (OPTIONAL TANDEM CYLINDER STROKE) – **MH2**
 Model Horiz. Stroke Vert. Stroke Mounting Style

Model	Motion	Guide Shaft Diameter	Bore	Standard Stroke Length
EZP5025	Horizontal	1/2"	1-1/8"	1" to 10" by 1" increments
	Vertical	1/4"	1-1/8"	1" to 5" by 1" increments
EZP7550	Horizontal	3/4"	2"	1" to 6" by 1" increments 8" to 18" by 2" increments
	Vertical	1/2"	1-1/8"	1" to 10" by 1" increments

3-Position Tandem Cylinder Pick & Place Units

(Tandem cylinder NOT available on vertical motion of EZP5025)
 Note: See pages 28 & 29 for principle of operation

Ordering example:

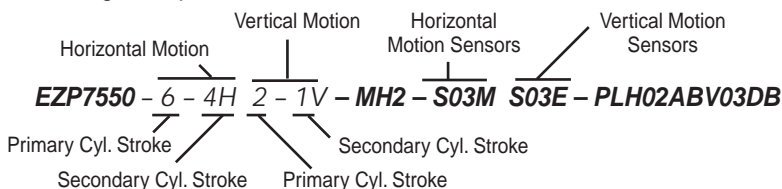

Sensor locations— use “M” in the Box () if mid-position sensor is required (3 sensors). - Note: “M” (mid-position) is **not** available with “S50, S51, S60” sensors. All sensors are located on the primary cylinder, which also contains the magnetic piston band for “E” & “J” options. Mid-position “M” prox sensor is not available on vertical motion of EZP5025 models with prox options (consider using “E” or “J” style sensors if mid-position sensing is required).

Port Locations: Top ports are standard on the horizontal motion on all tandem models. The horizontal motion of the EZP5025 Pick & Place is available with a top and bottom port combination as a “special” order at no additional charge. Consult factory.

Endcap Mounting Styles

MH1
Thru Mtg Holes

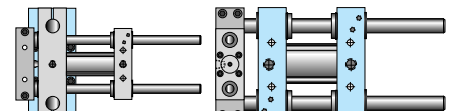

MH2
Tapped Mtg Holes

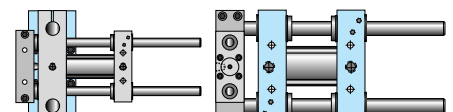

MF1
Front Flange Mtg Holes

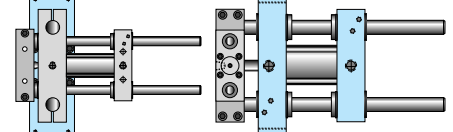

MF2
Rear Flange Mtg Holes

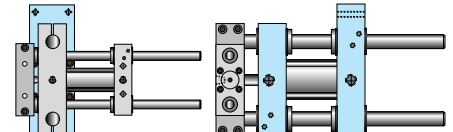

MF3
Front & Rear Flange Mtg

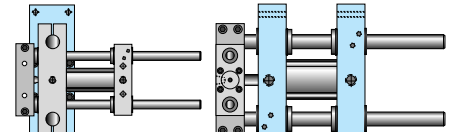

MV1
Side Tapped Mtg Holes

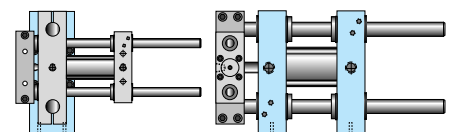

MV2
Side Tapped w/Ports on Opp. Side

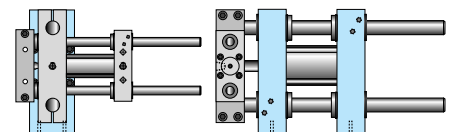

Optional “B1” Mounting Bars

For use with MV1 or MV2 Mounting style

To Order with EZP Unit:
 Add “B1” to mounting style of horizontal motion.

Example:
EZP7550 – 5H 2V – MV1B1

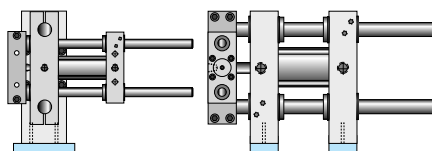

Building the Model Number in 3 Easy Steps

Step 2 Please turn the page

T20
Toolbar Options

Model Number Will End Here
If No Options Are Desired

– V
Integral Options

Continue on to step 2
if you want to add Sensing Options

Toolbar Options

Blank toolbar (no holes) is available as a no cost substitution.

Code

T1 Blank toolbar

Ordering example:

EZP7550-5H2V-MH2T1

Grippers

EZP5025 and EZP7550 model pick & place units are available with transition plate or toolbar that will directly mount a Fabco-Air “SPG” Series parallel gripper (see catalog #GR-7 for gripper details). Mounting details are shown on page 71 of this catalog. Specify toolbar code here; order gripper separately.

Model EZP5025

Code

T10 Transition plate for “SPG 100” gripper

T20 Transition plate for “SPG 200” gripper

T30 Transition plate for “SPG 300” gripper

Model EZP7550

Code

T20 Toolbar to mount “SPG 200” gripper

T30 Toolbar to mount “SPG 300” gripper

Integral Options

D □ □ –

Dowel Hole & Slot Code & Location(s)

Available on any of the mounting surfaces shown on page 60 & 61. **Example: D12 specifies dowel holes/slots on bottom surface of bearing block and on bottom surface of toolbar.**

H– Hydraulic Cylinder Seals (150 psi max.)

V– Viton Cylinder Seals

Bearing Options Sleeve Bearings can be substituted for standard linear ball bearings.

W– Rulon® Shaft Bearings

X– Duralon® Shaft Bearings

Guide Shaft Options

Y– Hollow Guide Shafts

Case hardened & ground #52100 tubular steel available on EZP7550 horizontal motion.

Z– Stainless Steel Guide Shafts: shaft material compatible with bearing type will be provided.

Bearing Type

Shaft Material

Std. linear ball brgs.

440C hardened & ground SS

Option “W” Rulon® sleeve

Hard chrome plated SS*

Option “X” Duralon® sleeve

Hard chrome plated SS*

*Note: Except EZP5025 vertical motion will be 440C material

To order a combination of these options, use multiple letters. **Example: –D2XVZ** specifies that a dowel hole, Duralon® shaft bearings, Viton seals and stainless steel guide shafts are built into the basic pick & place unit.

"EZP" Series Pick & Place Units – Order Guide

Step 2

Add sensors. Choices include proximity switches, snap action mechanical switches, 3-way air pilot switches, magnetically operated electronic sensors and reed switches. Available complete with sensors – or mounting brackets only if you are furnishing the sensors.

Step 2: Sensing Options

Model Number Ends Here
If No Other Options Desired

— **SO3B** **SO3E**
Horiz. Motion Vert. Motion

Sensor Codes (Use "S000" if NO Sensors are desired)

Select a code for sensor type and indicate position

Example: SO3 **B**

E = Extend position only
R = Retract position only
B = Both extend & retract positions
M = 3 sensors (See note 1)

• Sensors beginning with the letter "S" (Prox, Snap Action, Air Pilot) are actuated by "dogs" clamped to the guideshfts. • Sensors beginning with the letter "J" or "E" (Electronic sensors and reed switches) are actuated by a magnetic band on the piston.

Note 1: Mid position "M" not available on vert. motion of EZP5025 with prox options. "M" not available on any model with S50, S51, or S60.

Proximity Switch w/Brackets & Actuators

Prewired w/ 6' Leadwire	Quick Disconnect w/2 M cordset	Quick Disconnect without cordset	Thread Size	Electrical Characteristics
S01 <input type="checkbox"/>	S02 <input type="checkbox"/>	S12 <input type="checkbox"/>	12mm	110v AC, 2-wire, w/LED
S03 <input type="checkbox"/>	S04 <input type="checkbox"/>	S14 <input type="checkbox"/>	12mm	24v DC, 2-wire, w/LED (NPN/PNP)
S05 <input type="checkbox"/>	S06 <input type="checkbox"/>	S16 <input type="checkbox"/>	12mm	24v DC, 3-wire, w/LED (PNP) Sourcing
S07 <input type="checkbox"/>	S08 <input type="checkbox"/>	S18 <input type="checkbox"/>	12mm	24v DC, 3-wire, w/LED (NPN) Sinking
Proximity Switch Brackets & Actuators Only				
S40 <input type="checkbox"/>	S45 <input type="checkbox"/>	See note 2	12mm	Customer supplies the switches
S41 <input type="checkbox"/>	S46 <input type="checkbox"/>	See note 2	8mm	Customer supplies the switches
S42 <input type="checkbox"/>	S47 <input type="checkbox"/>	See note 2	5mm	Customer supplies the switches

Snap Action Mechanical Switches

Prewired w/ 6' Leadwire	Conduit Fitting Style Housing	Electrical Characteristics
S50 <input type="checkbox"/>	S51 <input type="checkbox"/>	SPDT 10 amp. capacity (See note 3)

Air Pilot Switch

S60 <input type="checkbox"/>	Miniature 3-way air valve (See note 3)
------------------------------	--

Magnetic Piston & Clamp-On Sensors ("J")

Single sensor –1" stroke min; Dual sensors –2" stroke min.

9 Ft. Prewired	Quick Disconnect w/5M cordset	Sensor Type	LED	Electrical Characteristics
J70 <input type="checkbox"/>	J71 <input type="checkbox"/>	Reed	Yes	5-120 VDC/VAC, 0.5 Amp Max, 10 Watt Max, SPST N.O., 3.5 Voltage Drop
J72 <input type="checkbox"/>	J73 <input type="checkbox"/>	Electronic	Yes	Sourcing PNP 6-24 VDC, 0.50 Amp Max, 1.0 Voltage Drop
J74 <input type="checkbox"/>	J75 <input type="checkbox"/>	Electronic	Yes	Sinking NPN 6-24 VDC, 0.50 Amp Max, 1.0 Voltage Drop

Magnetic Piston & Dovetail Style Sensors ("E")

For 1" Stroke & longer on all bores.

9 Ft. Prewired	Quick Disconnect w/5M cordset	Sensor Type	LED	Electrical Characteristics
E70 <input type="checkbox"/>	E71 <input type="checkbox"/>	Reed	Yes	5-120 VDC/VAC, 0.03 Amp Max, 4 Watt Max, 2.0 Voltage Drop
E72 <input type="checkbox"/>	E73 <input type="checkbox"/>	Electronic	Yes	Sourcing PNP 6-24 VDC, 0.20 Amp Max, 0.5 Voltage Drop
E74 <input type="checkbox"/>	E75 <input type="checkbox"/>	Electronic	Yes	Sinking NPN 6-24 VDC, 0.20 Amp Max, 0.5 Voltage Drop
E76 <input type="checkbox"/>	E77 <input type="checkbox"/>	Reed	No	0-120 VDC/VAC, 0.5 Amp Max, 5 Watt Max, 0 Voltage Drop

Magnetic Piston

J800 <input type="checkbox"/>	Customer supplies the sensors and mounting clamps
E800 <input type="checkbox"/>	Includes Dovetail Mounting Rail; customer supplies the sensors

EZP5025 showing snap action (vert. motion) and air pilot switches (horiz. motion)

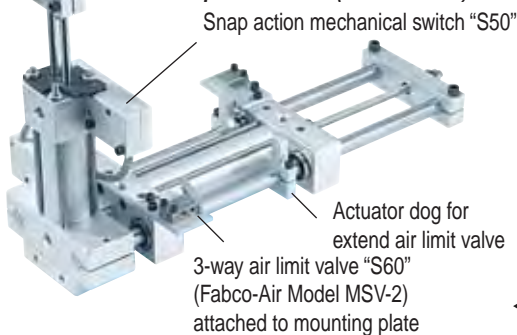

EZP7550 showing snap action (horiz. motion) and air pilot switches (vert. motion)

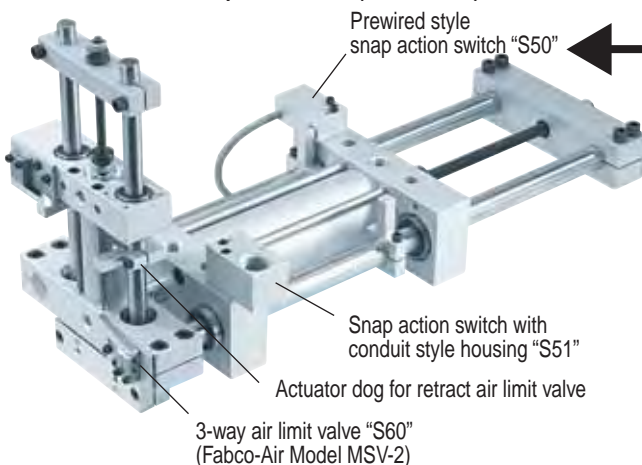

Note 2:

Codes "S45, S46 & S47" available on horizontal motion of EZP5025 and vertical motion of EZP7550 only

Note 3:

Not available on horizontal motion of EZP5025 with "MV1" or "MV1B1" mounting style

Step 3 Please turn the page

Continue on to step 3 if you want to add Tooling, Stop, or Hydraulic Shock Options.

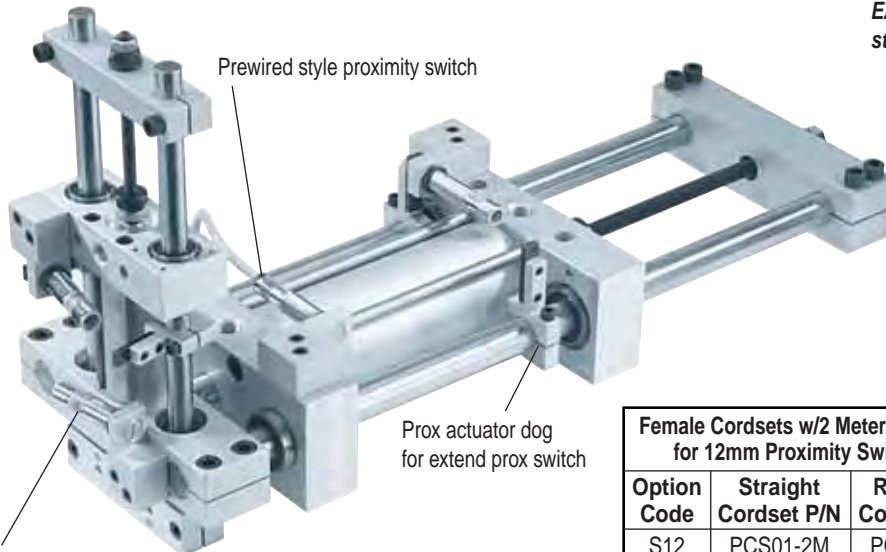

EZP7550 model showing both styles of proximity switches

Quick disconnect style proximity switch "S02, S04, S06, S08" is furnished with 2M cordset. For "S12, S14, S16, S18" order straight or right angle quick disconnect cordsets separately.

Female Cordsets w/2 Meter Leadwire for 12mm Proximity Switches

Option Code	Straight Cordset P/N	Rt. Angle Cordset P/N
S12	PCS01-2M	PCS02-2M
S14	PCS03-2M	PCS04-2M
S16	PCS05-2M	PCS06-2M
S18	PCS05-2M	PCS06-2M



4 meter and 6 meter cord sets are also available. Consult factory.

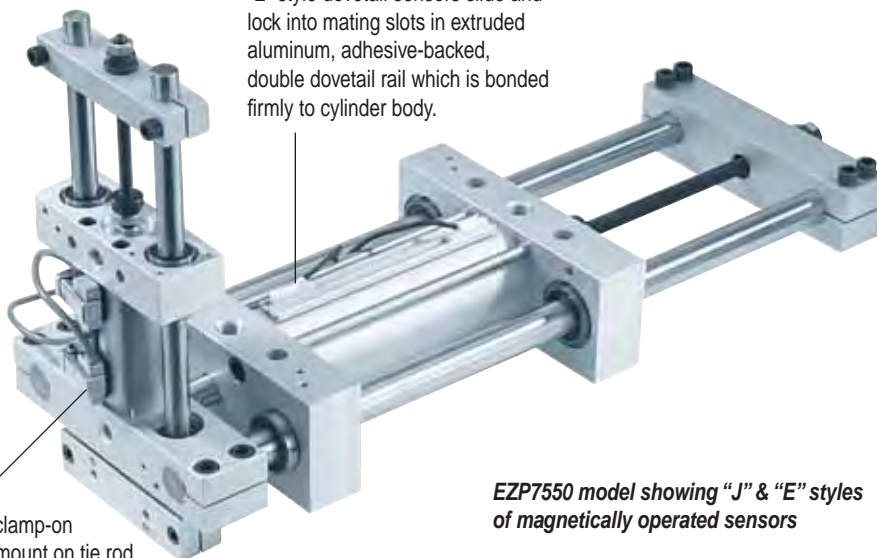

EZP7550 model showing "J" & "E" styles of magnetically operated sensors

“EZP” Series Pick & Place Units – Order Guide

Step 3

Select a tooling option to adapt the pick & place unit to the application. Is stroke adjustability required? Select from four adjustable stop options. Are hydraulic shock absorbers needed? Standard mounting brackets are available for both Ace and Enidine. You can order complete shock assemblies – or brackets only if you are furnishing the shocks.

Step 3: Tooling, Stop, & Shock Options

All 12 positions in this section must be filled with a character to be a valid model number. A tooling option must be selected before a stop and/or shock option can be specified.

RC
(Tooling Option)

H02
(Horiz. Stop)

AB
(Horiz. Shock)

V02
(Vert. Stop)

CE
(Vert. Shock)

Select a Tooling Option

Available Stop and Shock Options

Code – RC Rear Clampbar
For Model E郑5025
Includes clampbar on horizontal & vertical motions.

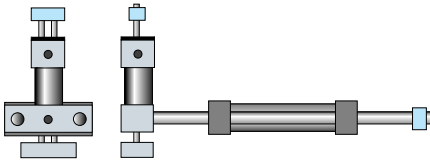

Horiz. Stop

Horiz. Shock

Vert. Stop

Vert. Shock

H00 = None desired

NO = None desired

V00 = None desired

NO = None desired

H01
HU1
H02

A
B
C

V04
Downstop only

A
B
C

Code – RC Rear Clampbar
For Model E郑7550
Includes clampbar on horizontal & vertical motions.

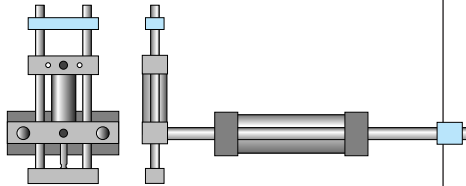

H00 = None desired

NO = None desired

V00 = None desired

NO = None desired

H01
HU1
H02

A
B
C

V01
VU1
V02

A
B
C

Code – BL Tall Blocks
For Model E郑7550 Vertical Motion
Includes clampbar on horizontal motion.

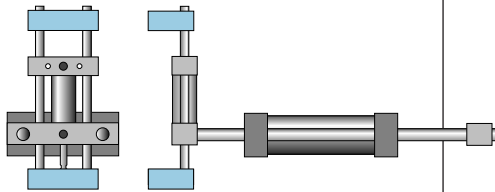

H00 = None desired

NO = None desired

V00 = None desired

NO = None desired

H01
HU1
H02

A
B
C

V01
VU1
V02
V03

A D
B E
C F

Code – PL Toolplate
For Model E郑7550 Vertical Motion
Includes clampbar on horizontal motion.

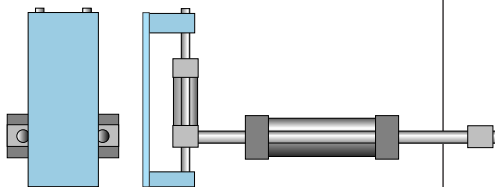

H00 = None desired

NO = None desired

V00 = None desired

NO = None desired

H01
HU1
H02

A
B
C

V01
VU1
V02
V03

A D
B E
C F

Completed model number

EZP7550-5H2V-MH2T20-V-SO3BS03E-RCH02ABV02CE

EZP7550 = EZP7550 P&P model
 5H = Horizontal stroke
 2V = Vertical stroke
 MH2 = Tapped mounting holes
 Horizontal motion
 T20 = Toolbar for SPG200

V = Viton seals
 SO3BS03E = 12mm prox switches 24 VDC, 2-wire
 6 ft. prewired leads. Horiz. motion
 = extend & retract positions. Vert.
 motion = extend only.
 RC = Rear clampbar on horiz. & vert. motion

H02 = Horizontal stop package
 AB = Ace shocks, standard location
 (horizontal motion, extend & retract)
 V02 = Vertical stop package
 CE = Shock brackets only, standard location
 (vertical motion, extend only)

Adjustable Stop Option Details

The **Step 3 chart** on the opposite page indicates what stops are available for each tooling option. **Indicate H or V in the box ()**.

Code 00 — This code indicates no stops desired.

Code 01 — Allows complete adjustment over the entire stroke length from full to zero stroke. Threaded rod (with two flange nuts serving as the stops) is fastened to cylinder endcap. Flange nuts provide the adjustments.

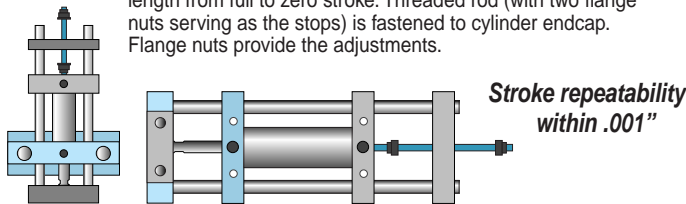

Code U1 — Reduces noise and provides an impact absorbing stop cushion. It is the same stop as Type "01" with a urethane washer slipped onto the threaded rod against the flange nut.

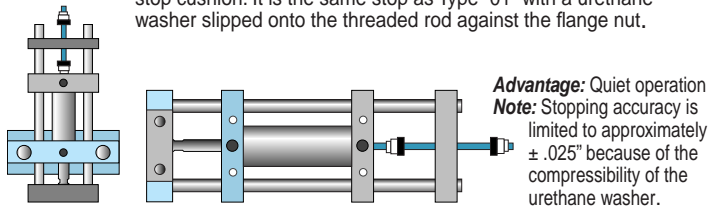

Code 02 — Is a modification of Type "01" where a stop bolt is added for the extend stop. It positions both extend and retract adjustments next to each other at the back of the motion. Provides easier, more accessible adjustment in cases where a "PL" or "BL" tooling option would cover the extend flange nut in a Type "01" stop.

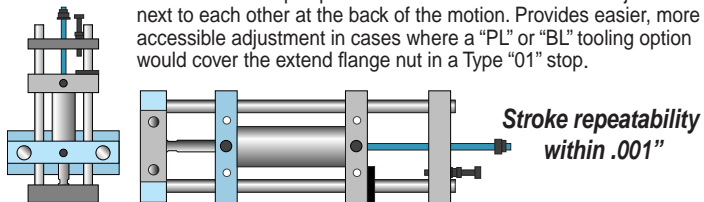

Code 03 — For use with "BL" or "PL" tooling options on Model EZP7550.

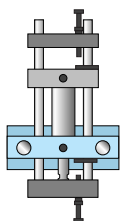

Code V04 — Stop bolt at one end — Downstop only. For use with EZP5025 vertical motion only.

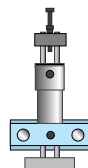

Stroke repeatability within .001"

General shock notes:

1) EZP5025 uses 1/2"-20 thread shocks/brackets on horizontal and vertical motions. 2) EZP7550 uses 1/2"-20 thread shocks/brackets on vertical motion, and 1"-12 thread on horizontal motion. 3) EZP5025 vertical motion shock option is only available with 2" or longer vertical strokes.

Shock Option Details

The **Step 3 chart** on the opposite page indicates what shocks are available for each tooling option.

Indicate shock quantity/location in the box ()

as follows: **E = Extend only;**
R = Retract only;
B = Both extend and retract.

Code N0 — Indicates no shocks
Standard Shock Location

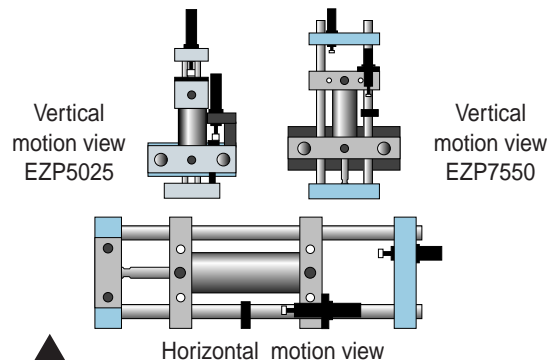

Standard Location Alternate Location

A Ace Shocks **D** Enidine Shocks
B Enidine Shocks **E** Brackets & Actuators only
C Brackets & Actuators only **F** (Customer supplies the shocks)

Insert E, R or B in box

Alternate Shock Location for Vertical Motion of EZP7550

Recommended when using "BL" or "PL" Tooling

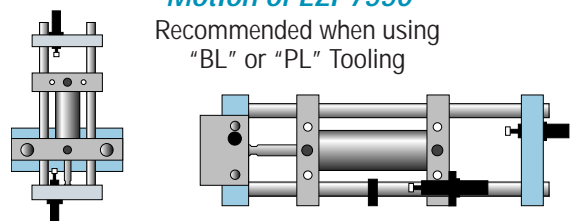

"EZP" Series Pick & Place Units

EZP5025

MH1, MH2 Mounting Style

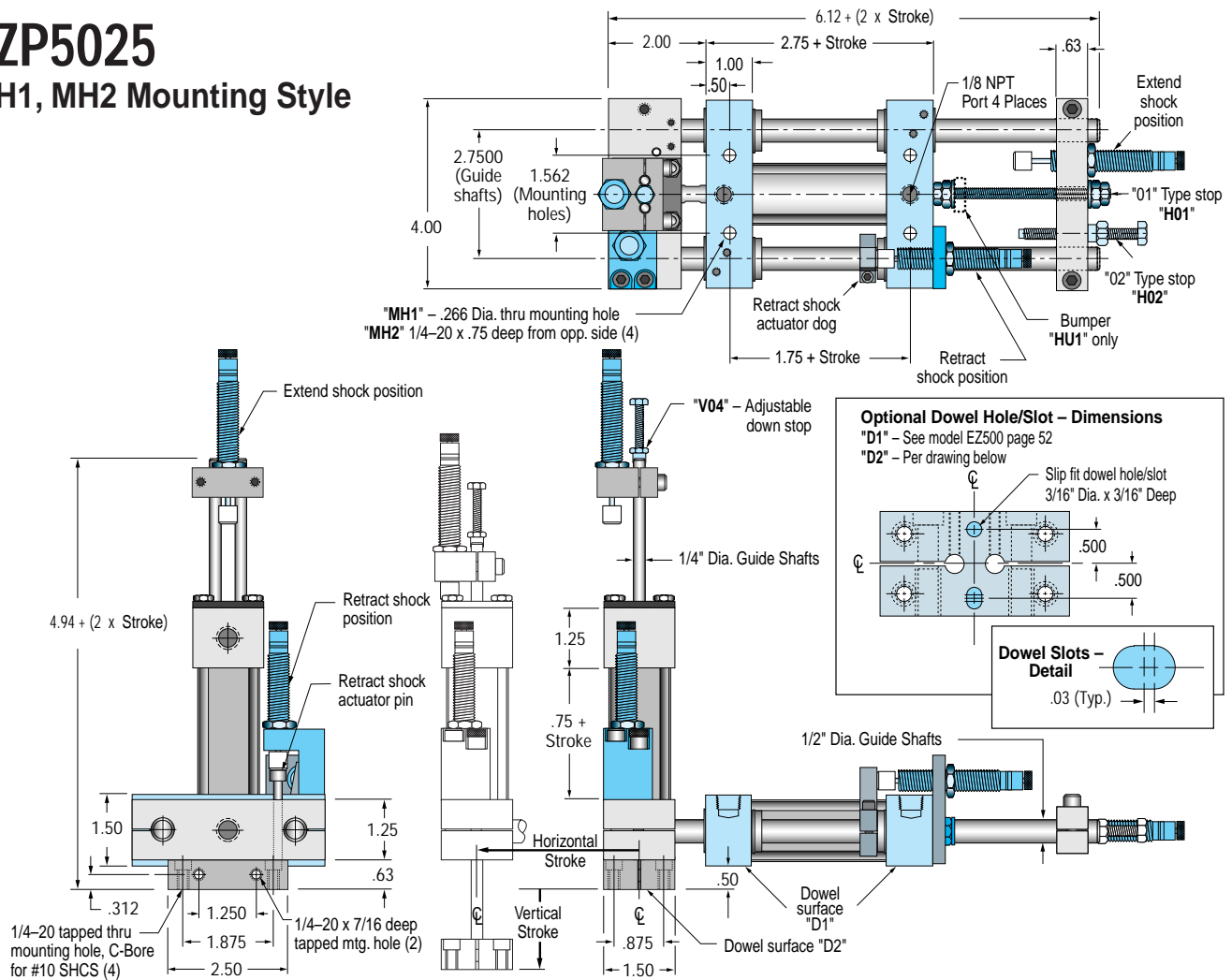

MF1, MF2, MF3 Mounting Style

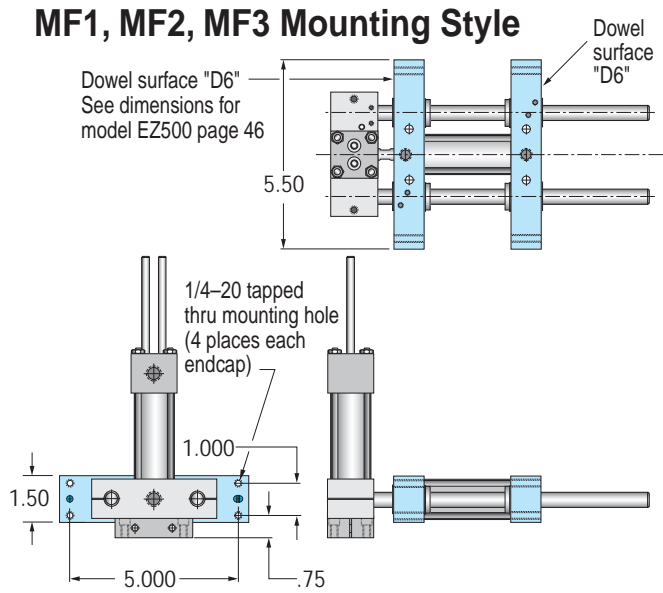

MV1, MV2 Mounting Style

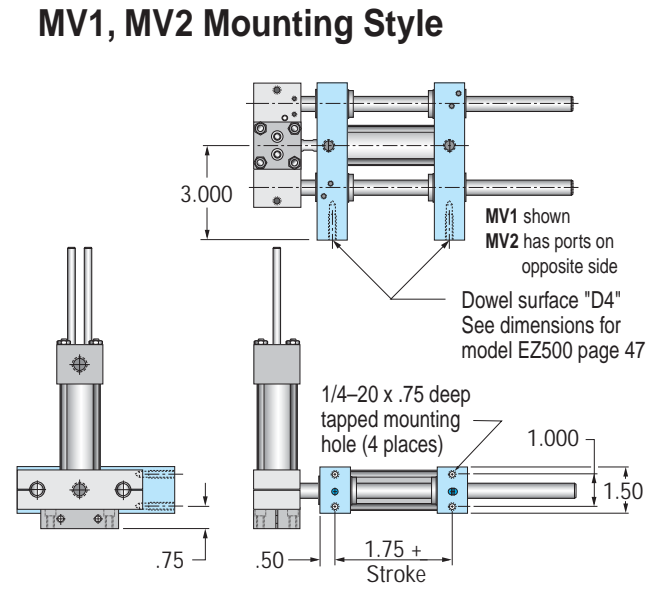

"EZP" Series Pick & Place Units

EZP5025

with Tandem horizontal motion

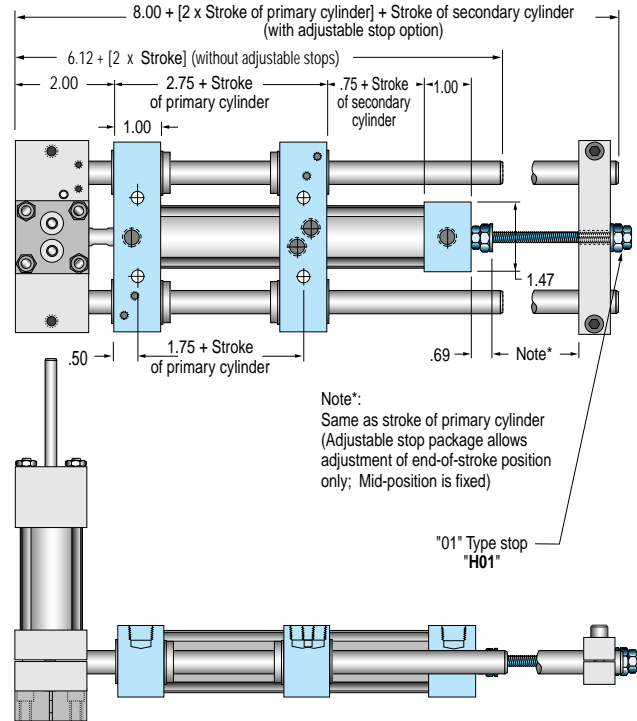
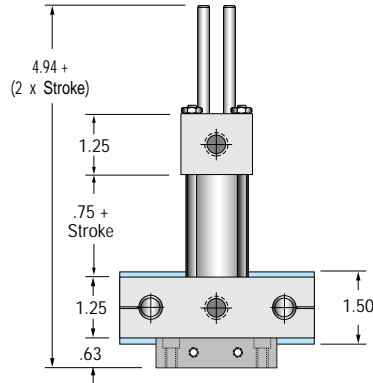

EZP7550

with Tandem horizontal motion and Tandem vertical motion

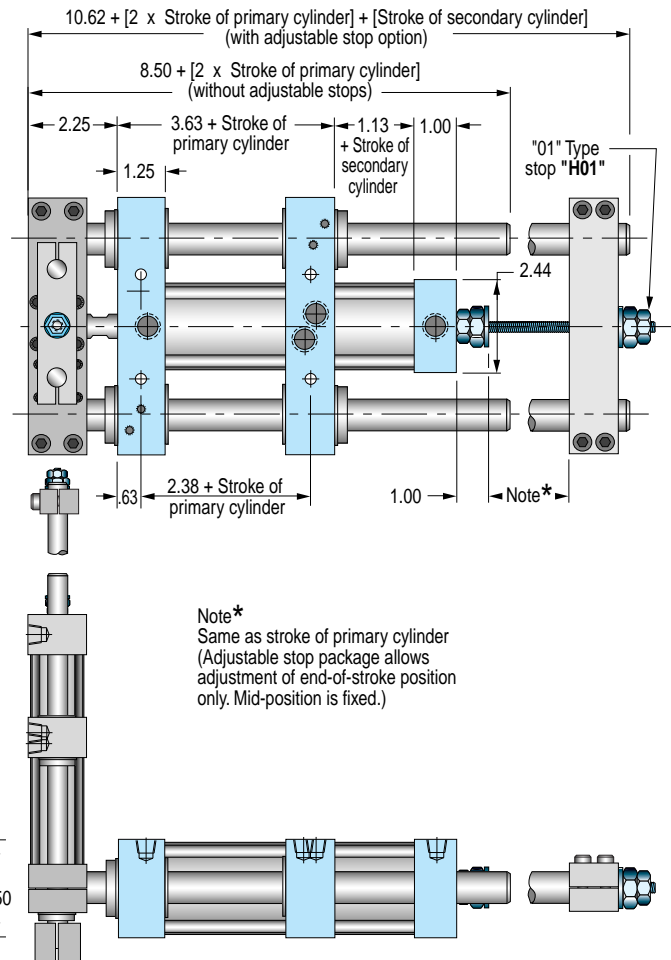
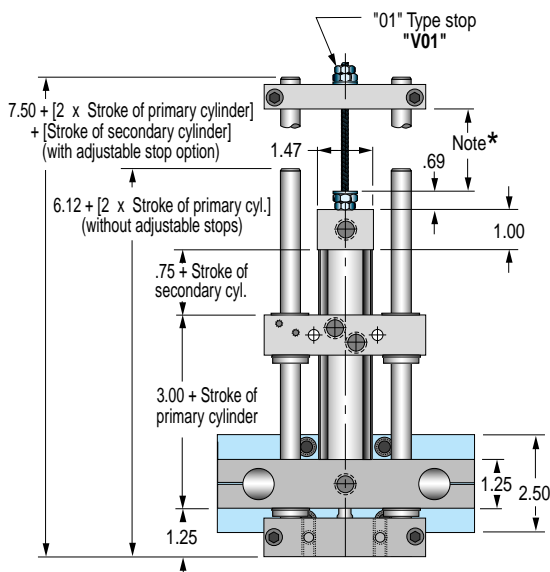

Tandem cylinder models & units with "SPG" Grippers

EZP5025 with "SPG" Series Parallel Gripper

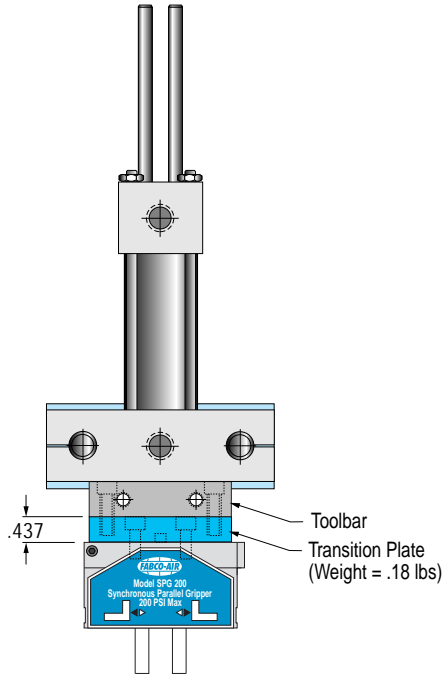

Ordering example:

EZP5025 – 3H1V – MH1T20 – D12

T20 is transition plate for **SPG200** gripper

D12 is optional dowel hole/slot in horizontal mounting surface and dowel hole/slot in bottom toolbar surface

Transition Plate Options

Code	Gripper Model
T10	SPG100
T20	SPG200
T30	SPG300

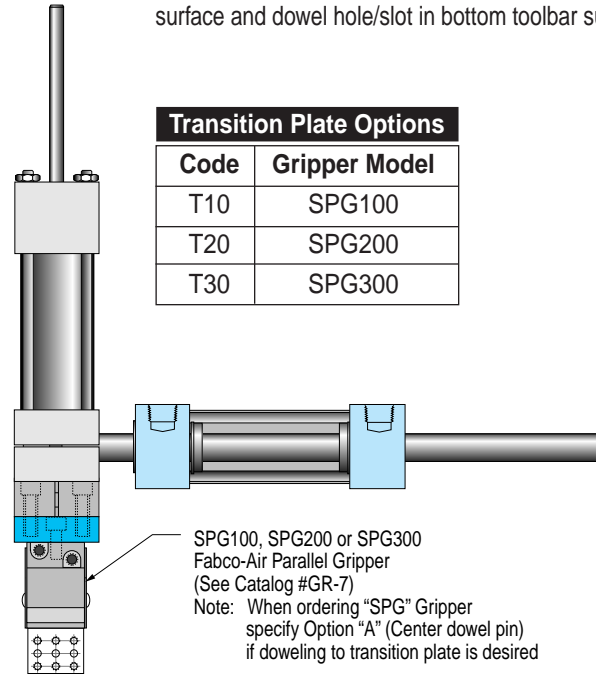

EZP7550 with "SPG" Series Parallel Gripper

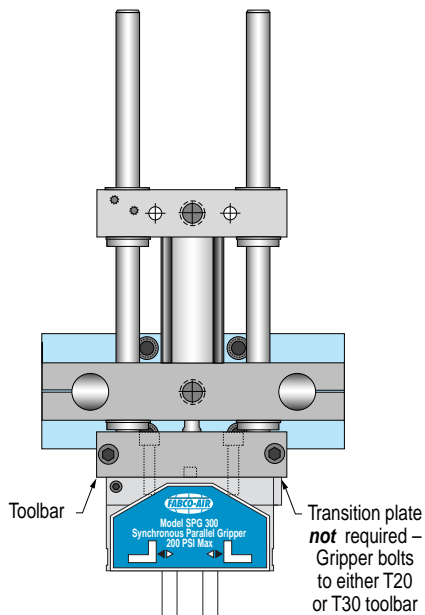

Ordering example:

EZP7550-6H5V-MH1T30

T30 is toolbar with mounting holes for **SPG300** gripper. (T20 & T30 are supplied with center dowel hole as a standard feature)

Toolbar Options

Code	Gripper Model
T20	SPG200
T30	SPG300

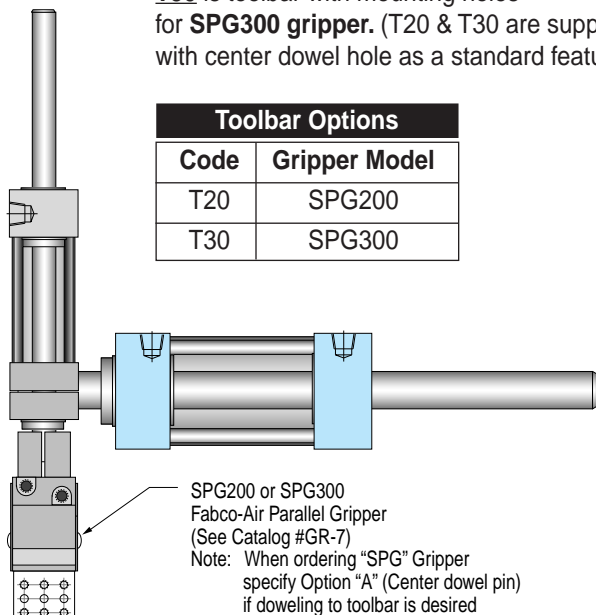

"TS" Series Linear Slides

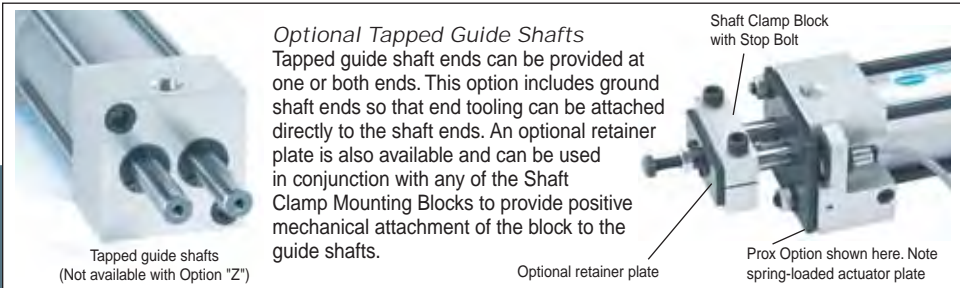
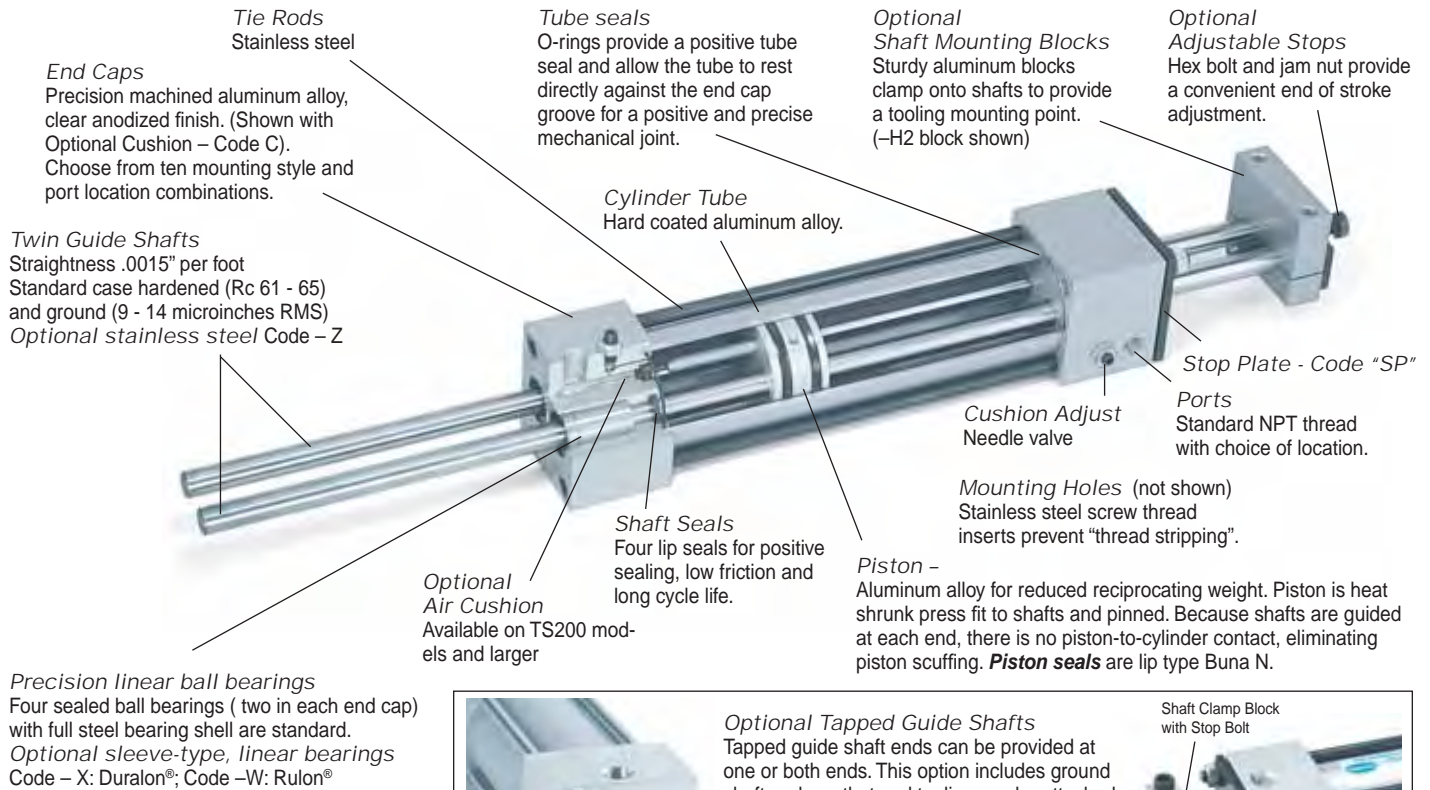

Engineering Data

Model	TS112	TS150	TS200	TS250	TS325	TS400
Bore	1-1/8"	1-1/2"	2"	2-1/2"	3-1/4"	4"
Power Factor Ext. & Retract	.89	1.55	2.75	4.29	7.41	10.99
Guide Shaft Diameter	1/4"	3/8"	1/2"	5/8"	3/4"	1"
Weight, lbs. @ zero stroke	.88	2.05	3.96	7.03	11.76	22.02
Add lbs per inch of stroke	.12	.25	.40	.59	.82	1.29
Standard Strokes	1" to 10" by 1" incr.	1" to 12" by 1" incr.	1" to 15" by 1" incr.	1" to 20" by 1" incr.	1" to 20" by 1" incr.	1" to 20" by 1" incr.

Pressure Rating: Maximum operating pressure is 150 psi Air

Output Force: Output Force = Pressure x Power Factor

Speed: Safe speed range: without cushions – 6 to 8 inches per second; with cushions – 8 to 16 inches per second. Tandem hydraulic shock absorbers can be provided for speeds exceeding 18 inches per second, or for heavy reciprocating weights. Contact factory for application assistance.

Load Limits: Safe loading involves a combination of factors including: bearing capacity, shaft strength and allowable deflection, life expectancy, how the load is applied, and how fast the load is accelerated/decelerated.

– DO NOT OVERLOAD – Overloading can cause reduced product life, shaft bending and loss of positional accuracy, as well as bearing and seal failure. CAUTION: Heavy reciprocating loads can create damaging impact forces at end of stroke. It may be necessary to use adjustable stop bolts, air cushions, or special hydraulic shock absorbers – or reduce speeds.

Compact, Precision Slides Housed Within Cylinder Bodies

Load Sizing Guide

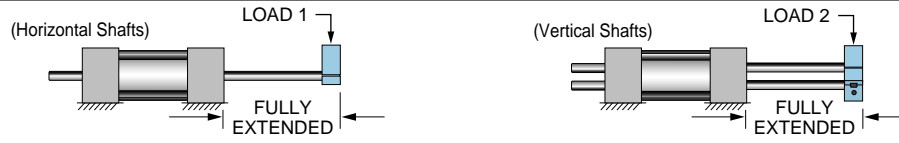

Load Limits: Chart shows maximum loading for precision applications. Load (in pounds) will produce .005" deflection or less. Additional loading will cause increased shaft deflection, especially on long strokes. If your application does NOT require that shaft deflection be held to less than .005", TS Series slides can be loaded higher than charted values. Consult factory for maximum safe load capacities.

Model Number	Load Type	Stroke																			
		1"	2"	3"	4"	5"	6"	7"	8"	9"	10"	11"	12"	13"	14"	15"	16"	17"	18"	19"	20"
TS112	Load 1	9.9	8.7	3.8	1.6	1.0	0.5	0.4	0.3	0.1	0.1										
	Load 2	17	16.1	7.6	5.5	2.0	1.0	0.8	0.5	0.3	0.3										
TS150	Load 1	13	11.5	7.0	4.2	2.2	1.5	1.2	0.8	0.7	0.5	0.3	0.2								
	Load 2	23	19	14	8.2	4.4	3.0	2.4	1.6	1.4	1.0	0.6	0.5								
TS200	Load 1	58	54	26	13	8.0	4.0	3.5	3.1	2.5	1.9	1.6	1.3	1.1	1.0	0.4					
	Load 2	71	63	42	26	16	8.0	7.0	6.2	5.0	3.8	3.2	2.6	2.2	2.0	0.8					
TS250	Load 1	74	69	61	30	18	11	8.0	5.0	4.8	4.6	3.8	3.1	2.5	2.1	1.6	1.2	0.7	0.6	0.5	0.4
	Load 2	89	78	69	60	36	22	16	10	9.6	9.2	7.6	6.2	5.0	4.2	3.2	2.4	1.4	1.2	1.0	0.9
TS325	Load 1	180	170	160	98	62	34	21.5	12.5	10.5	8.5	7.6	6.1	4.9	3.8	3.3	2.8	2.5	2.1	1.8	1.5
	Load 2	216	210	202	196	124	68	43	25	21	17	15.2	12.2	9.8	7.6	6.6	5.6	5.0	4.2	3.6	3.0
TS400	Load 1	320	280	240	200	143	86	64	42	32	22	17	12.5	11.2	10	9.6	9.2	7.2	5.2	4.6	4.0
	Load 2	384	376	367	365	286	176	128	84	64	44	34	25	22.4	20	19.2	18.4	14.4	10.4	9.2	8.0

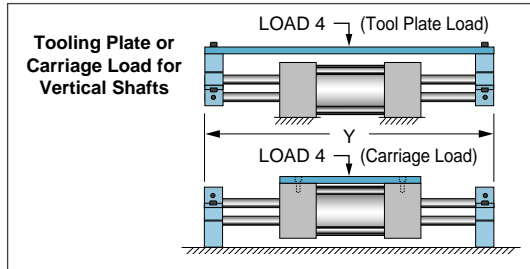
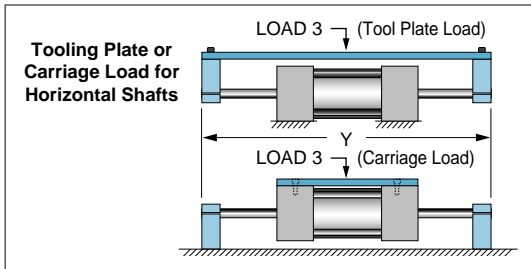

Strokes longer than charted below are **NOT** recommended. shaded area indicates standard strokes; indicates non-standard strokes.

Model Number	Tooling Plate / Carriage Load – (Maximum loads in pounds at mid-stroke producing .005" deflection or less)																			
	Stroke	1"	2"	3"	4"	5"	6"	7"	8"	9"	10"	11"	12"	13"	14"	15"	16"	17"	18"	20"
TS112	Y(inches)	8	10	12	14	16	18	20	22	24	26									
	Load 3	11	10.5	8.3	6.9	4.7	3.2	2.6	2.0	1.5	1.0									
	Load 4	17	16.5	16	15.5	12.7	6.5	5.7	3.3	2.4	1.8									
	Y(inches)	9.25	11.25	13.25	15.25	17.25	19.25	21.25	23.25	25.25	27.25	29.25	31.25							
TS150	Load 3	14.8	14	13.8	11.6	10.1	8.5	6.5	4.5	3.7	3.0	2.5	2.0							
	Load 4	23.0	22.3	21.6	20.8	18.9	17.1	13.0	9.1	7.6	6.0	4.6	3.2							
	Y(inches)	10.63	12.63	14.63	16.63	18.63	20.63	22.63	24.63	26.63	28.63	30.63	32.63	34.63	36.63	38.63				
	Load 3	58	52	38	24.5	20.2	16	12	8.0	7.5	6.9	6.6	6.3	5.9	5.1	4.0				
TS200	Load 4	71	63	55	46.1	39.5	32	24	16	15	13.8	13.2	12.5	11.2	9.8	7.5				
	Y(inches)	11.88	13.88	15.88	17.88	48	21.88	23.88	25.88	27.88	29.88	31.88	33.88	35.88	37.88	39.88	41.88	43.88	45.88	49.88
	Load 3	74	69.2	64.5	60	73	36	29.5	23	19.5	16	13	10	9.8	9.6	9.4	9.2	7.7	6.2	3.1
	Load 4	89	85	81	77	10"	69.5	59	46	39	32	26	20	19.6	19.2	18.8	18.4	15.4	12.4	5.9
TS325	Stroke	2"	4"	6"	8"	31	12"	14"	16"	18"	20"	22"	24"	26"	28"	30"				
	Y(inches)	15	19	23	27	43	35	39	43	47	51	55	59	63	67	71				
	Load 3	180	120	93	68	80	25	20.5	16.5	14.3	12.2	10	7.8	6.8	5.8	5.0				
	Load 4	216	192	168	124	10"	50	41	33	28.6	24.4	20	15.6	13.6	11.6	10				
TS400	Stroke	2"	4"	6"	8"	34.25	12"	14"	16"	18"	20"	22"	24"	26"	28"	30"	32"	34"	36"	
	Y(inches)	18.25	22.25	26.25	30.25	84	38.25	42.25	46.25	50.25	54.25	58.25	62.25	66.25	70.25	74.25	78.25	82.25	86.25	
	Load 3	320	246	172	128	168	64	44	35	26	23	20	18.7	16.5	13.5	10.5	9.2	8.0	6.8	
	Load 4	384	364	344	256		128	88	70	52	46	40	37	33	27	21	18	16	13.5	

"TS" Series Linear Slides – Order Guide

Step 1 Select a model size with guide shaft diameters required by loading/deflection considerations – or with cylinder bore/thrust requirements. Determine stroke and mounting required. Select built-in cylinder options: Air Cushions, Tapped Guide Shafts, Stop Plates, Metallic or Urethane Scrapers. Helpful hint: **Model number indicates cylinder bore size in 2 place decimals. Example: the TS112 cylinder bore is 1.12".**

Step 1: Basic Slide Model

Model Number Will End Here If No Options Are Desired Leave Blank If No Integral Options Are Desired

TS 200 – 12 – MH2 – D – V – TG SB

Series Model Size Stroke Mounting Style & Port Locations Integral Options

Model Size	Bore	Guide Shaft Diameter	Standard Strokes in 1" Increments
112	1-1/8"	1/4"	1" to 10"
150	1-1/2"	3/8"	1" to 12"
200	2"	1/2"	1" to 15"
250	2-1/2"	5/8"	1" to 20"
325	3-1/4"	3/4"	1" to 20"
400	4"	1"	1" to 20"

Integral Option Codes Use "dashes" to separate

D – Dowel Hole/Slot in Mounting Surface
V – Viton Cylinder Seals
Z – Stainless Guide Shafts, 440C hardened, ground

Bearing Options Sleeve Bearings can be substituted for the standard linear ball bearings.

W – Rulon® Shaft Bearings
X – Duralon® Shaft Bearings

Mounting Style & Port Locations

MH1 Horizontal Shafts, Side Ports High – Opposite Sides

MV1 Vertical Shafts, Side Ports on Center – Opposite Sides

MH2 Horizontal Shafts, Side Ports High & Low – Same Side

MV2 Vertical Shafts, Side Ports on Center – Same Side

MH3 Horizontal Shafts, Top Ports on Center

MV3 Vertical Shafts, Top Ports – Staggered

MH4 Horizontal Shafts, Bottom Ports on Center

MV4 Vertical Shafts, Bottom Ports – Staggered

MF1 / MF2 Flange Mount Ports on Center
 MF1 – thru holes
 MF2 – tapped holes

For the options shown below, indicate the desired location in the box () as follows: **L** = Left hand end only; **R** = Right hand end only; **B** = Both ends

Tapped Guide Shafts Code **TGS** Not available with Option "Z"

Stop Plate Code **SP** required for use with stop bolt unless one of the prox options S01 – S42 is used.

Air Cushions Code **C** + cushion length
 Use 2-digit number to specify length as a number of 1/8" increments. **Not available for TS112 or TS150**
 Max. Cushion Lengths
 TS200: 1-5/8" (13 eighths) TS325: 2-1/4" (18 eighths)
 TS250: 2" (16 eighths) TS400: 3" (24 eighths)

Example: For a TS250 with 1" cushions at both ends, the cushion code is **– CB08**

Rod Scrapers, Metallic Code **MS**
Rod Scrapers, Urethane Code **US**
 see page 80

Optional Attachments

"B1" Bars **"B2" Bars**

"B1" Mounting Bars for MV or MH Mounting
"B2" Mounting Bars For Use With Side Proximity Switch Option and MV or MH Mounting. (B2 not required, and therefore not available, on TS400 models.)

To Order with Slide: Add **"B1"** or **"B2"** to mounting style. **Example: TS250 – 12 – MH1B2**

Building the Model Number in 3 Easy Steps

Step 2 Determine the type of position sensing needed. Choices include proximity switches, or magnetically operated electronic sensors and reed switches. Available complete with sensors – or mounting brackets only if you are furnishing the sensors.

Step 2: Sensing Options

Proximity Switches w/Brackets & Actuators

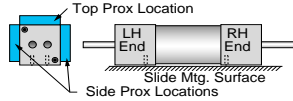

Code followed by switch location in 1st box (□): **T** = top surface; **S** = side surface, and quantity in 2nd box (□): **L** = left end only; **R** = right end only; **B** = both ends. Prox switches are available complete with 12mm switches and actuators (S01 thru S18), or brackets & actuators only (S40 - S42). All mounting styles have top & side prox locations available except MH3 & MV3 have side locations only. Side mounted switches have both switches on the same side except MH1 & MV1 which have switches located on opposite sides.

Proximity Switch w/Brackets & Actuators

Prewired w/ 6' Leadwire	Quick Disconnect w/2 M cord set	Quick Disconnect without cord set	Thread Size	Electrical Characteristics
S01 □□	S02 □□	S12 □□	12mm	110v AC, 2-wire, w/LED
S03 □□	S04 □□	S14 □□	12mm	24v DC, 2-wire, w/LED (NPN/PNP)
S05 □□	S06 □□	S16 □□	12mm	24v DC, 3-wire, w/LED (PNP) Sourcing
S07 □□	S08 □□	S18 □□	12mm	24v DC, 3-wire, w/LED (NPN) Sinking

Proximity Switch Brackets & Actuators Only

S40 □□	12mm	Customer supplies the switches
S41 □□	8mm	Customer supplies the switches
S42 □□	5mm	Customer supplies the switches

Magnetically Actuated Sensors

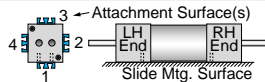

Electronic sensors and reed switches are available as a package complete with magnetic piston. Sensors J70 thru J75 are tie rod mounted; Sensors E70 thru E77 are dovetail style and mounted in a rail on the cylinder body. **The two boxes (□) indicate location & quantity.** First box indicates attachment surface: 1, 2, 3 or 4. In the 2nd box, **L** = left end, **R** = right end, **B** = both ends. Example: **J703R** has one top-mounted sensor on the right end.

Magnetic Piston & Clamp-On Sensors ("J")

9 Ft. Prewired	Quick Disconnect w/5M cord set	Sensor Type	LED	Electrical Characteristics
J70 □□	J71 □□	Reed	Yes	5-120 VDC/VAC, 0.5 Amp Max, 10 Watt Max, SPST N.O., 3.5 Voltage Drop
J72 □□	J73 □□	Electronic	Yes	Sourcing PNP 6-24 VDC, 0.50 Amp Max, 1.0 Voltage Drop
J74 □□	J75 □□	Electronic	Yes	Sinking NPN 6-24 VDC, 0.50 Amp Max, 1.0 Voltage Drop

Magnetic Piston & Dovetail Style Sensors ("E")

9 Ft. Prewired	Quick Disconnect w/5M cord set	Sensor Type	LED	Electrical Characteristics
E70 □□	E71 □□	Reed	Yes	5-120 VDC/VAC, 0.03 Amp Max, 4 Watt Max, 2.0 Voltage Drop
E72 □□	E73 □□	Electronic	Yes	Sourcing PNP 6-24 VDC, 0.20 Amp Max, 0.5 Voltage Drop
E74 □□	E75 □□	Electronic	Yes	Sinking NPN 6-24 VDC, 0.20 Amp Max, 0.5 Voltage Drop
E76 □□	E77 □□	Reed	No	0-120 VDC/VAC, 0.5 Amp Max, 5 Watt Max, 0 Voltage Drop

Magnetic Piston ; customer supplies the sensors

J8000	Magnetic piston only.
E80 □□	Includes dovetail mounting rail; Specify location 1, 2, 3 or 4 in box (□)

Model Number Ends Here If No Bolt-on Options Are Desired

– **S03TB**
(5 Digits)

– Use S0000 if no Sensing Options Are Desired)

Model number ends here if no Bolt-on Options are desired. Continue on to Step #3 if you need any of these options.

Prox Switches w/Brackets & Actuators

Prox switch requires a tooling option with stop bolt (or customer tooling) to drive the switch actuator plate

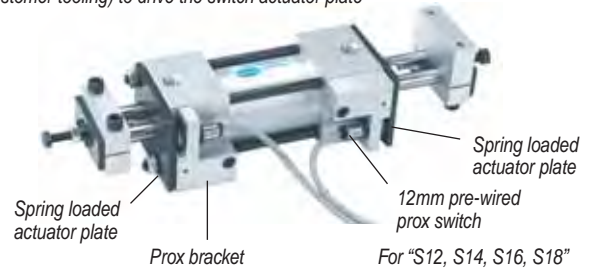

For "S12, S14, S16, S18" order straight or right angle cord set separately.

Female Cordsets w/2 Meter Leadwire for 12mm Proximity Switches

Option Code	Straight Cordset P/N	Rt. Angle Cordset P/N
S12	PCS01-2M	PCS02-2M
S14	PCS03-2M	PCS04-2M
S16	PCS05-2M	PCS06-2M
S18	PCS05-2M	PCS06-2M



4 meter and 6 meter cord sets are also available. Consult factory.

Clamp On Style Sensors "J70 - J75"

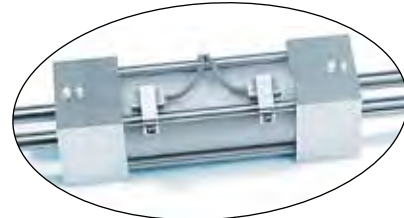

Sensor clamps mount on the cylinder tie rods

Dovetail Style Sensors "E70 - E77"



Adhesive backed, double dovetail rail bonds firmly to cylinder body; dovetail sensors slide and lock into mating slots in the rail.

"TS" Series Linear Slides

Step 3: Bolt-on Options

→ -H2R - H3L - RPB

Bolt-on Options

Specify **Left Hand**, **Right Hand**, or **Both** with "L", "R", or "B" in boxes (). Use "dashes" to separate options.

Horizontal Shaft Mounting Block

H1 without stop bolt
H2 with stop bolt (shown) See Note 1



Vertical Shaft Mounting Block

V1 without stop bolt
V2 with stop bolt (shown) See Note 1



Shaft Clamp Block with Stop Bolt

H3 Stop bolt is used for stroke adjustment. See Note 1



Note 1: The aluminum end caps of the TS slide cannot be used as a stopbolt contact surface. A steel stop plate must be used. Specify either Integral Option "SP" or Prox Option "S01 - S42"

Retainer Plate

RP Retainer plate. Must be used in conjunction with "TGS" option and one of the accessory blocks.



Retainer Plate

Tooling Mounting Plate

Cannot be used with top ports, with top proximity switch bracket, or with "J" Style sensor options



Vertical Shaft View Horizontal Shaft View

PL V Tooling mounting plate and pair of vertical shaft mounting blocks.

PL H Tooling mounting plate and pair of horizontal shaft mounting blocks.

In first box () use an "A" to specify Aluminum, or an S " to specify Steel. In the second box () use "1" meaning without Stop Bolt, or a "2" meaning with Stop Bolt.

On-Center Port Locations ("MH3, MH4, MV1, MV2")

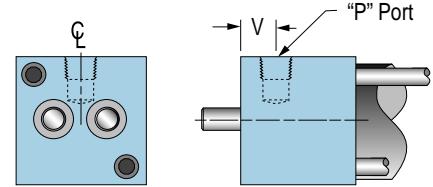

Corner Port Locations ("MH1, MH2, MV3, MV4")

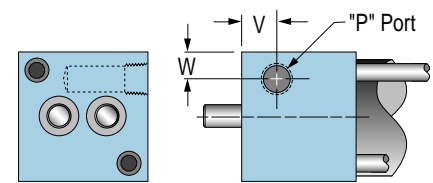

"Dowel Hole/Slot Option (Code "-D") for "MH" & "MV" mounting styles

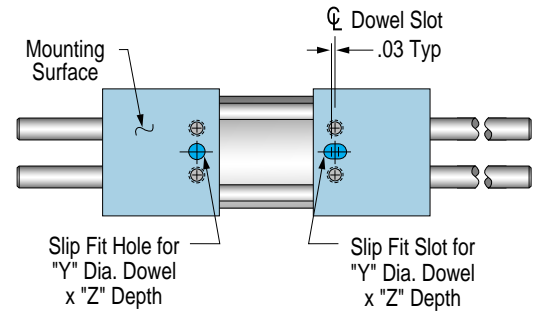

Threaded Guide Shafts (Code "-TGS ")

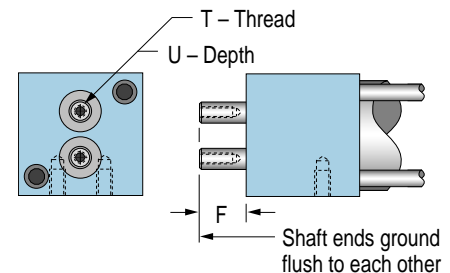

"TS" Series Dimensional Data

Model	Bore	Shaft Dia. S	A	AA	B	BB	C	CC	D	DD
TS112	1-1/8	.249	3.50	3.94	.969	1.125	1.562	2.000	1.38	1.81
TS150	1-1/2	.374	4.25	4.75	1.125	1.500	2.000	2.750	1.44	1.94
TS200	2	.499	5.13	5.88	1.562	1.875	2.000	3.375	1.81	2.56
TS250	2-1/2	.624	5.88	6.75	1.875	2.000	2.125	4.000	2.19	3.06
TS325	3-1/4	.749	6.50	7.50	2.000	2.500	2.500	5.250	2.44	3.44
TS400	4	.999	8.25	9.38	2.750	3.250	2.750	6.250	3.13	4.25

Mounting Style Dimensions

Horizontal Shafts Mounting Style “-MH□”

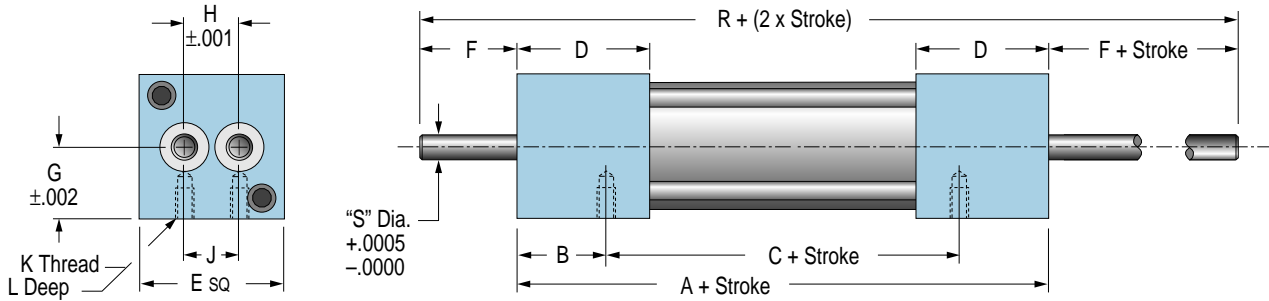

Vertical Shafts Mounting Style “-MV□”

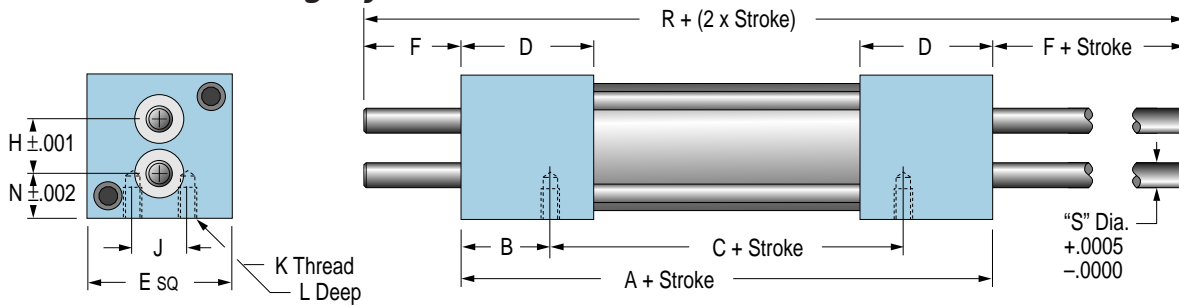

Flange Mounting Style “-MF1 & MF2”

(“MF1” – Thru hole mounting)

(“MF2” – Tapped hole mounting)

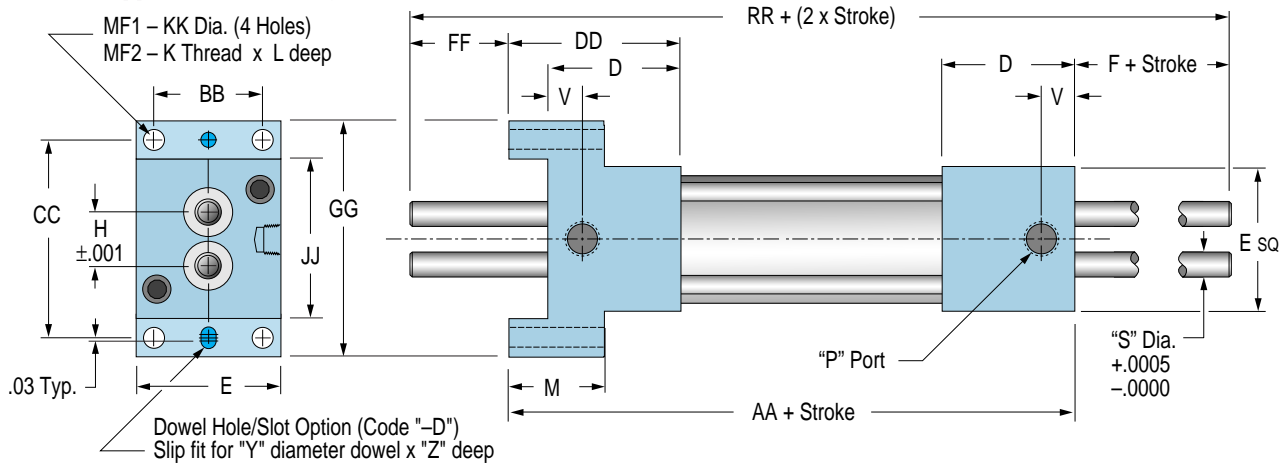

E	F	FF	G	GG	H	J	JJ	K	KK	L	M	N	P Port	R	RR	T	U	V	W	Y	Z
1.500	1.25	1.00	.750	2.375	.562	.562	1.63	#10-24	.203	.38	1.000	.469	1/8 NPT	6.00	6.19	#4-40	.38	.38	.28	3/16	.18
2.000	1.50	1.75	1.000	3.250	.750	.812	2.13	1/4-20	.266	.50	1.250	.625	1/4 NPT	7.25	8.00	#8-32	.50	.44	.41	1/4	.25
2.500	1.75	1.75	1.250	4.000	1.000	1.000	2.63	5/16-18	.328	.63	1.750	.750	1/4 NPT	8.63	9.38	#10-24	.63	.50	.50	1/4	.25
3.000	2.00	2.00	1.500	5.000	1.375	1.250	3.25	3/8-16	.391	.63	2.000	.812	1/4 NPT	9.88	10.75	1/4-20	.63	.63	.63	1/4	.25
3.750	2.25	2.50	1.875	6.500	1.875	1.750	4.00	7/16-14	.453	.63	2.250	.937	3/8 NPT	11.00	12.25	5/16-18	.88	.75	.75	3/8	.37
4.500	3.00	3.00	2.250	7.500	2.250	2.250	4.75	1/2-13	.531	.75	2.500	1.125	3/8 NPT	14.25	15.38	3/8-16	.88	.88	.88	3/8	.37

"TS" Series Linear Slides

Horizontal Shaft Mounting Block

(Code "-H1" without stop bolt)

(Code "-H2" includes stop bolt)

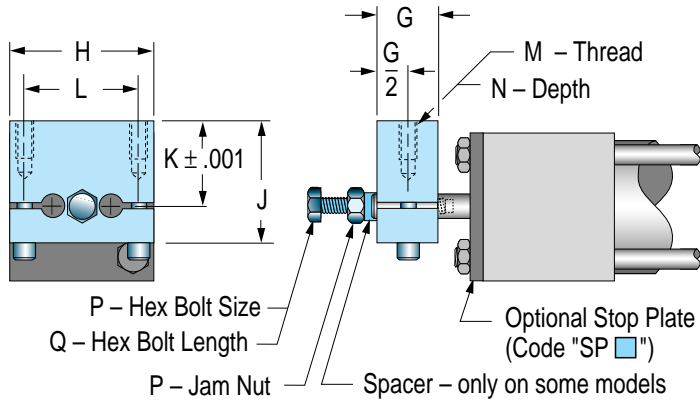

Shaft Clamp Block with Stop Bolt

(Code "-H3")

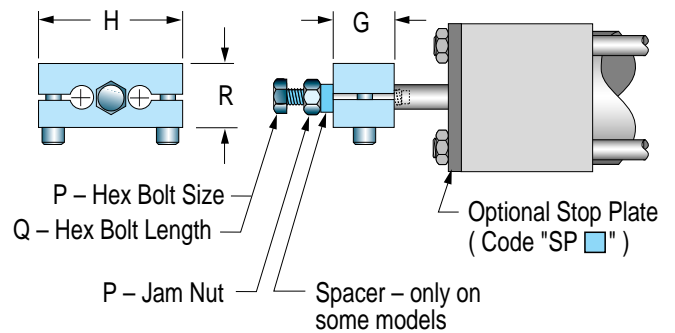

Vertical Shaft Mounting Block

(Code "-V1" without stop bolt)

(Code "-V2" includes stop bolt)

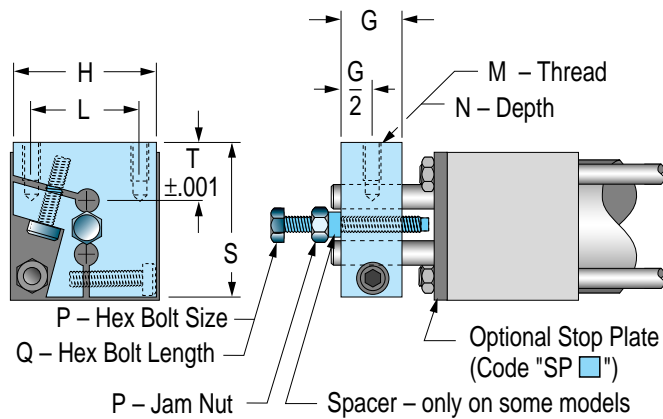

Stop Plate (Code "-SP")

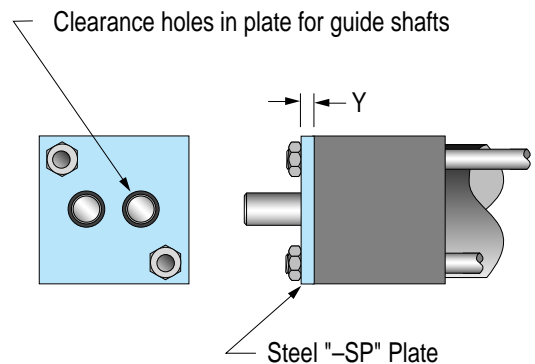

"TS" Series Dimensional Data

Model	Bore	A	AA	B1	B2	BB	C1	C2	CC	D1	D2	DD	E	F	G	GG
TS112	1-1/8	.250	.16	.75	1.25	.13	2.50	3.25	.40	2.000	2.750	.75	.218	.656	.63	1.625
TS150	1-1/2	.250	.16	.75	1.50	.13	3.50	4.00	.51	2.750	3.250	.75	.281	.750	.75	2.125
TS200	2	.375	.23	1.00	1.50	.19	4.00	4.50	.64	3.250	3.750	.75	.344	.750	.75	2.625
TS250	2-1/2	.375	.25	1.00	2.00	.19	5.00	5.50	.71	4.000	4.500	.75	.406	.875	1.00	3.125
TS325	3-1/4	.500	.31	1.25	2.25	.25	5.75	6.38	.81	4.750	5.375	.75	.469	1.125	1.00	3.875
TS400	4	.625	.50	1.25	N/A	.38	7.00	N/A	1.09	5.750	N/A	.75	.531	N/A	1.50	4.750

Tooling Mounting Plate Package

(Code “-PL V ” for vertical shafts)

(Code “-PL H ” for horizontal shafts)

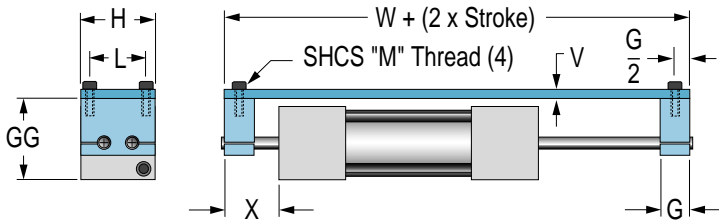

In the first box () of the option code an "A" or an "S" specifies **A**luminum or **S**teel. In the second box () a "1" signifies stop bolts **not** desired; a "2" specifies stop bolts at each end.

Base Mounting Bars -B1 & -B2

(For use with "MH" or "MV" mounting)

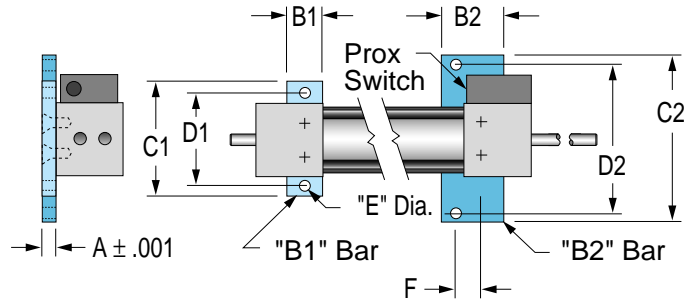

Base mounting bars are made from ground steel stock with black oxide surface treatment.

Note: Use "B2" option when side mounted prox bracket would interfere with "B1" mounting holes.

Retainer Plate (Code “-RP ”)

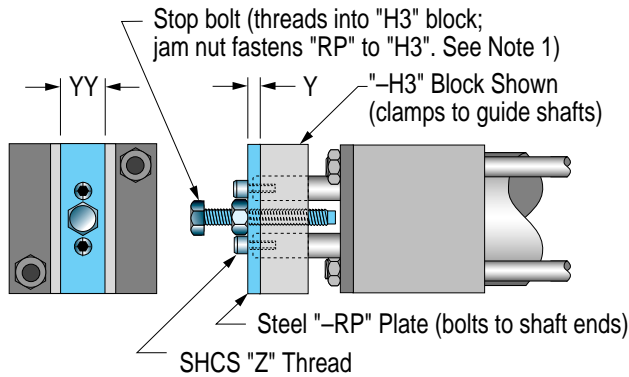

Retainer plate option must be used in conjunction with "TGS" tapped guide shafts option and one of the bolt-on accessory blocks ("H1, H2, H3, V1, V2"). Provides positive mechanical attachment of the block to the guide shafts. **Note 1: Socket head cap screw is used to fasten "RP" to clamblocks without stop bolt.**

Prox Switch (Codes "S01 " thru "S42 ")

Prox switch actuator plate is spring loaded and rides on flanged bushings.

Prox switch option requires a tooling option with stop bolt (or customer tooling) to drive the actuator plate.

Bolt-on tooling options "H2, V2, & H3" include stop bolt.

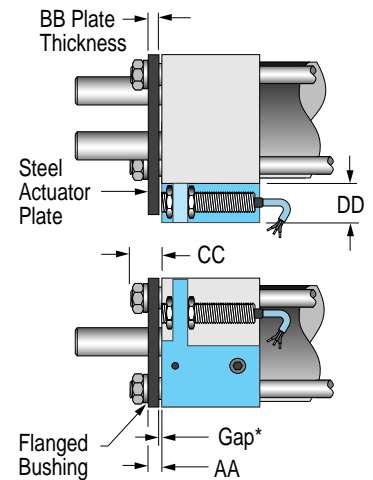

*Note: Gap = "AA" - "BB"

	H	J	K	L	M	N	P	Q	R	S	T	V	W	X	Y	YY	Z	Bore	Model
	1.50	1.25	.875	1.125	#10-24	.44	#10-24	1.50	.75	1.59	.594	.250	5.88	1.19	.13	.50	#4-40	1-1/8	TS112
	2.00	1.75	1.125	1.500	1/4-20	.50	1/4-20	2.50	1.25	2.09	.750	.250	7.12	1.44	.13	.75	#8-32	1-1/2	TS150
	2.50	2.06	1.375	1.875	5/16-18	.63	5/16-18	2.50	1.50	2.59	.875	.375	8.38	1.63	.19	1.00	#10-24	2	TS200
	3.00	2.38	1.625	2.375	5/16-18	.63	3/8-16	3.00	1.50	3.09	.937	.375	9.62	1.88	.19	1.00	1/4-20	2-1/2	TS250
	3.75	3.00	2.000	3.062	3/8-16	.63	7/16-14	3.50	2.00	3.84	1.062	.500	10.75	2.12	.25	1.00	5/16-18	3-1/4	TS325
	4.50	3.75	2.500	3.750	3/8-16	.88	1/2-13	4.00	2.50	4.69	1.375	.750	14.00	2.88	.38	1.50	3/8-16	4	TS400

"TS" Series Linear Slides

Air Cushion Option

Available on TS200 Models and larger

Construction – The cushion option consists of a needle valve adjacent to the port, a spud attached to the piston, and a lip type seal that acts both as a seal and a check valve.

Operation – As the slide nears the end of stroke, the spud enters the check seal, closing off the exhaust port and forcing the captured air to exhaust through the adjustable needle valve, providing a smooth, controlled deceleration. On the return stroke, the pressurized air collapses the rim of the lip seal allowing full air flow and providing a quick breakaway.

Cushion length can be specified. Long cushion spud allows slide to be adjusted to stop short of full stroke, and still have plenty of controlled cushioning.

Ordering

Code "C " (location L, R, or B in box) plus a 2-digit number to specify the cushion length as a number of 1/8" increments. Maximum cushion lengths are shown below; minimum cushion length is 3/4".

Model	Max. Cushion Lengths
TS200	... 1-5/8" .. (13 eighths)
TS250	... 2" (16 eighths)
TS325	... 2-1/4" . (18 eighths)
TS400	... 3" (24 eighths)

Example: For a TS250 with 1-1/2" cushions at both ends, the cushion code is – **CB12**

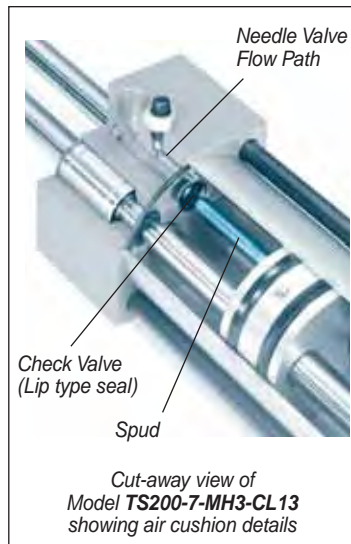

Rod Scraper Available on all TS sizes

Construction – The rod scraper option consists of a steel plate attached to the tie rods that houses a pair of exclusion rings (metallic or urethane) which will effectively remove contaminants that may cling to the guide shafts in severe environments (such as metal cutting machinery applications where "sticky" coolant is used).

The optional proximity switches and adjustable stop bolts (shown elsewhere in this catalog section) cannot be used with the scraper option.

Magnetically actuated sensors (Codes "J" & "E") are compatible with the scraper option.

Special adjustable stops can be provided. Please contact the factory or your local Fabco-Air distributor.

Ordering

Code "MS " Metallic Rod Scraper (Location L, R, or B in box)
Code "US " Urethane Rod Scraper (Location L, R, or B in box)



"MS" Metallic scraper shown here

Step 1

TS200 – 12.0 – MH2

Indicate "TS" series

Select model size from chart below

Model Size	Bore	Guide Shaft Diameter
112	1-1/8"	1/4"
150	1-1/2"	3/8"
200	2"	1/2"
250	2-1/2"	5/8"
325	3-1/4"	3/4"
400	4"	1"

Select a stroke (Special strokes also available)

Choose Mounting Style & port locations

Mounting Styles

- MH1** Horizontal Shafts, Side Ports High Opposite Sides
- MH2** Horizontal Shafts, Side Ports High & Low Same Side
- MH3** Horizontal Shafts, Top Ports on Center
- MH4** Horizontal Shafts, Bottom Ports on Center
- MV1** Vertical Shafts, Side Ports on Center Opposite Sides
- MV2** Vertical Shafts, Side Ports on Center Same Side
- MV3** Vertical Shafts, Top Ports – Staggered
- MV4** Vertical Shafts, Bottom Ports, Staggered

For use with MH or MV only

- B1 Mounting Bars
- B2 Mounting Bars (except TS400)

- MF1** Thru hole mounting
- MF2** Tapped hole mounting
- Flange Mount
- Ports on Center

Model Standard Stroke Length

TS112	1" to 10" by 1" increments
TS150	1" to 12" by 1" increments
TS200	1" to 15" by 1" increments
TS250	1" to 20" by 1" increments
TS325	1" to 20" by 1" increments
TS400	1" to 20" by 1" increments

How to Order Summary

-D -V -TGSB

Select
Integral
Options

Integral Options

- D**– Dowel Hole and Slot
- V**– Viton Cylinder Seals
- Z**– Stainless steel guide shafts, 440C hardened and ground

Bearing Options

Sleeve bearings can be substituted for the standard linear ball bearings

- W**– Rulon® Sleeve Bearings
- X**– Duralon® Sleeve Bearings

For the options shown below, indicate the desired location in the box (□) as follows: **L** = Left hand end only; **R** = Right hand end only; **B** = Both ends

Tapped Guide Shafts

TGS □ – Not available with option "Z"

Stop Plate

SP □ – Required for use with Stop Bolt unless one of the prox options S01 – S42 is used

Air Cushions (TS200 and larger)

C □ + 2 digits to express cushion length in number of 1/8 increments

Rod Scrapers, Metallic

MS □ – see page 86

Rod Scrapers, Urethane

US □ – see page 86

Step 2

– S03TB

Sensor Options

Sensor Options

S000 – Indicates no sensors desired

Proximity Switches w/Brackets & Actuators

Note: Indicate switch location in the 1st box

□ □ "T" = top surface; "S" = side surface

Indicate switch quantity in the 2nd box

□ □ "L" = Left end, "R" = Right end, "B" = Both ends

S01 □ □ thru **S18** □ □

12mm Prox Switch w/Brackets & Actuators

- Choose desired electrical characteristics
- Choose pre-wired or quick disconnect with or without cord set

S40 □ □ thru **S42** □ □

Prox Switch Brackets & Actuators Only, no Switches.

- Choose 12mm, 8mm, or 5mm

Magnetically Actuated Sensors

Note: Indicate switch location in the 1st box

□ □ Indicate surface location "1, 2, 3, or 4"

Indicate quantity in the 2nd box

□ □ "L" = Left end, "R" = Right end, "B" = Both ends

J70 □ □ thru **J75** □ □

Magnetic Piston and Clamp-on Sensors.

- Choose reed or electronic (PNP or NPN)
- Choose pre-wired or quick disconnect with cord set

J8000

Magnetic Piston Only, No Sensors

E70 □ □ thru **E77** □ □

Magnetic Piston & Dovetail Style Sensors

- Choose reed or electronic (PNP or NPN)
- Choose pre-wired or quick disconnect with cord set.

E80 □ 0

(Surface location "1, 2, 3, or 4" in box)

Magnetic Piston & Dovetail Mounting Rail (attached only, no sensors.

Step 3

– H2R – H3L – RPB

Bolt-on Options

Horizontal Shaft Mounting Block

Specify **L, R, or B** in box (□).

H1 □ – without stop bolt

H2 □ – with stop bolt (Requires "SP" or any prox option)

Vertical Shaft

Mounting Block

Specify **L, R, or B** in box (□).

V1 □ – without stop bolt

V2 □ – with stop bolt (Requires "SP" or any prox option)

Shaft Clamp Block

with Stop Bolt

Specify **L, R, or B** in box (□).

H3 □ – stop bolt is used for stroke adjustment. (Requires "SP" or any prox option)

Retainer Plate

Specify **L, R, or B** in box (□).

RP □ – retainer plate must be used in conjunction with TGS option and one of the accessory blocks – H1, H2, H3, V1, or V2

Tooling Mounting Plate

Specify **Aluminum or Steel** in first box (□) with "A" or "S".

In second box (□) use "1" meaning without stop bolt, or "2" meaning with stop bolt.

PL □ **V** □ – Tooling mounting plate and pair of vertical mounting blocks.

PL □ **H** □ – Tooling mounting plate and pair of horizontal mounting blocks.

Double Dovetail Mounting Rail – New Sensor Mounting System

Double dovetail mounting rail –	Part No.	Price
includes adhesive-backed foam tape for application to the O.D. of thin wall cylinders equipped with magnetic piston band.	ER – □ where length in inches is specified in box (□)	2.95
	add per inch of length	1.05

“GB” Series Linear Slides

“GB” Series: Standard strokes	Base list price	Adder per inch	
Model 375: 1/2, 1, 1-1/2, 2,3,4,5,6	\$147.95	\$8.25	
Model 500: 1,2,3,4,5,6,7,8,9,10	165.10	9.95	
Model 750: 1,2,3,4,5,6,7,8,9,10	213.70	10.10	
“GB” Series Options	GB375	GB500	GB750
V – Viton seals	3.35	4.45	6.30
E – Magnetic piston	4.80	7.80	14.50
T1 – Blank toolbar	N/C	N/C	N/C
A – Clamp collar / bumper	17.80	23.10	30.65
B – Rear clampbar / bumper	37.10	44.10	63.10
C – Tapped guideshafts / Rear	21.60	22.60	26.00
D – Stopbolt package	64.45	70.60	92.80
F – Rear toolbar	56.40	63.50	85.00

4mm Round Sensors – Electrical Characteristics							Part Numbers and Prices			
Sensor Type	Function	Switching Voltage	Switching Current	Switching Power	Switching Speed	Voltage Drop	Prewired 9 ft. Part No.	Price	Quick Connect Part No.	Price
Reed Switch for PLC's w/LED (current limiting)	SPST Normally Open	5-120V AC/DC 50/60 Hz	0.04 Amp max 0.005 Amp min.	4 Watts max.	0.5 ms operate 0.1 ms release	2.5 Volts	9C49-000-002	\$19.30	9C49-000-302 Requires 3 pin cordset	\$25.70
Electronic LED and Sourcing	PNP Normally Open	6-30 VDC	0.2 Amp max.	6 Watts max.	1.5µs operate 0.5µs release	1.5 Volts	9C49-000-031	27.30	9C49-000-331 Requires 3 pin cordset	31.65
Electronic LED and Sinking	NPN Normally Open	6-30 VDC	0.2 Amp max.	6 Watts max.	1.5µs operate 0.5µs release	1.5 Volts	9C49-000-032	27.30	9C49-000-332 Requires 3 pin cordset	31.65

Female Cordsets for Quick Disconnect Sensors	Cordset Length	Part No.	Price
	1 meter, 3 pin	CFC-1M	\$14.35
	2 Meters, 3 pin	CFC-2M	16.05
	5 Meters, 3 pin	CFC-5M	20.30

"L" Series Linear Slides

Step 1 – "L" Series Basic Slide Model		L250	L375	L500	L750	L1000	L1250	L3-1250
"L" Series Base Price	–MH1 Standard thru mounting holes	\$157.70	\$163.00	\$174.75	\$256.50	\$367.50	\$478.50	\$592.40
	Add per inch of stroke	3.95	4.10	5.55	7.85	11.65	38.45	39.30
	–MH1BP ("L" Series only) MH1 w/base plate	179.80	191.90	213.30	313.80	463.60	613.40	727.05
	Add per inch of stroke	3.95	5.00	7.00	10.05	15.20	44.40	45.25
	–MH2 Tapped mounting holes style	168.00	173.50	185.75	270.50	383.20	496.05	609.95
	Add per inch of stroke	3.20	4.10	5.55	7.85	11.65	38.45	39.30
–MV1 Side tapped mounting style		183.45	189.35	202.45	291.60	406.90	522.30	636.20
	Add per inch of stroke	3.20	4.10	5.55	7.85	11.65	38.45	39.30
–MV2 Side tapped mounting style – ports opposite		183.45	189.35	202.45	291.60	406.90	522.30	636.20
Stroke adder	Add per inch of stroke	3.20	4.10	5.55	7.85	11.65	38.45	39.30
Special strokes	add for non-standard strokes	consult factory						
Mounting Bars	B1 for use with MV1 or MV2 – add price per pair	18.75	21.60	24.30	34.50	40.35	46.15	46.15
Integral Options	–C Cushions	N/A	N/A	32.70	36.55	46.10	80.60	140.35
	–V Viton® cylinder seals	8.75	11.90	11.90	13.60	15.80	17.90	24.30
Toolbars	–T1, T5, T6, T7 (no additional cost)	–	–	–	–	–	–	–

Step 2 – "L" and "S" Series Sensing Options			L250 or \$250	L375 or \$375	L500 or \$500	L750 or \$750	L1000 or \$1000	L1250 or \$1250	L3-1250 or \$3-1250
Clamp-on Style "J" Sensors	–J70 Reed switch, 2-wire type with 9 foot leadwire	E Extend or R Retract	N/A	\$32.35	\$32.35	\$32.35	\$32.35	\$32.35	\$32.35
		B Extend & retract	N/A	64.75	64.75	64.75	64.75	64.75	64.75
	–J71 Quick discon. reed switch, without cord set	E Extend or R Retract	N/A	44.90	44.90	44.90	44.90	44.90	44.90
		B Extend & retract	N/A	89.70	89.70	89.70	89.70	89.70	89.70
	–J72, –J74 Electronic sensor, with 9 ft. leadwire	E Extend or R Retract	N/A	38.55	38.55	38.55	38.55	38.55	38.55
		B Extend & retract	N/A	77.25	77.25	77.25	77.25	77.25	77.25
–J73, –J75 Quick disconnect Electronic sensor without cordset	E Extend or R Retract	N/A	51.65	51.65	51.65	51.65	51.65	51.65	
	B Extend & retract	N/A	103.30	103.30	103.30	103.30	103.30	103.30	
Dovetail Style "E" Sensors	–E70 Reed switch, 2-wire type with 9 foot leadwire	E Extend or R Retract	N/A	29.30	29.30	29.30	29.30	29.30	29.30
		B Extend & retract	N/A	48.15	48.15	48.15	48.15	48.15	48.15
	–E71 Quick discon. reed switch, without cord set	E Extend or R Retract	N/A	36.85	36.85	36.85	36.85	36.85	36.85
		B Extend & retract	N/A	63.20	63.20	63.20	63.20	63.20	63.20
	–E72, –E74 Electronic sensor, with 9 ft. leadwire	E Extend or R Retract	N/A	34.40	34.40	34.40	34.40	34.40	34.40
		B Extend & retract	N/A	58.20	58.20	58.20	58.20	58.20	58.20
	–E73, –E75 Quick discon. Electronic sensor without cordset	E Extend or R Retract	N/A	41.85	41.85	41.85	41.85	41.85	41.85
		B Extend & retract	N/A	73.15	73.15	73.15	73.15	73.15	73.15
	–E76 Reed switch with 9 foot leadwire	E Extend or R Retract	N/A	28.55	28.55	28.55	28.55	28.55	28.55
B Extend & retract		N/A	46.65	46.65	46.65	46.65	46.65	46.65	
–E77 Quick discon. reed switch without cord set	E Extend or R Retract	N/A	36.10	36.10	36.10	36.10	36.10	36.10	
	B Extend & retract	N/A	61.70	61.70	61.70	61.70	61.70	61.70	
–E800 Dovetail style mounting rail only		N/A	10.50	10.50	10.50	10.50	10.50	10.50	
Cordsets	CFC-1M –1 Meter cable with female connector	14.35							
	CFC-2M –2 Meter cable with female connector	16.05							
	CFC-5M –5 Meter cable with female connector	20.30							

Step 3 – "L" Series Tooling & Stop Options		L250	L375	L500	L750	L1000	L1250	L3-1250
Tooling Options	–RT Rear toolbar	\$52.60	\$55.50	\$58.40	\$61.90	\$67.05	\$80.50	\$80.50
	–PL Tooling mounting plate plus – add per inch of stroke	83.40	94.95	111.00	139.05	186.95	233.15	245.35
		1.40	1.85	2.95	4.35	7.00	9.80	9.80
Stop Collars See Note 1	–KE Stop collars extend only	20.40	21.55	23.35	26.10	29.80	33.50	33.50
	–KR Stop collars retract only	20.40	21.55	23.35	26.10	29.80	33.50	33.50
	–KB Stop collars extend & retract	40.75	43.10	46.65	52.25	59.60	67.00	67.00
Urethane Bumpers See Note 1	–UE Bumpers extend only, w/stop collars	22.40	24.25	26.55	30.25	35.30	40.50	40.50
	–UR Bumpers retract only, no stop collars	2.05	2.60	3.20	4.10	5.55	7.00	7.00
	–UB Bumpers both ends w/stop collars extend	24.50	26.80	29.70	34.30	40.85	47.50	47.50

Note 1 – "L" Series slides require a collar with a machined flat, adding cost over standard type clamp collars.

"S" Series Linear Slides

Step 1 – "S" Series Basic Slide Model		S250	S375	S500	S750	S1000	S1250	S3-1250
"S" Series Base Price	–MH1 Standard thru mounting holes	\$135.55	\$144.30	\$149.55	\$225.80	\$335.95	\$478.50	\$592.40
	–MH2 Tapped mounting holes style	145.80	154.85	160.65	239.80	351.70	496.05	609.95
	–MF1 Front flange mounting style ("S" Series only)	156.35	165.30	171.80	253.85	367.50	514.15	633.35
	–MV1 Side tapped mounting style	161.25	170.60	177.30	260.85	375.35	522.30	636.20
	–MV2 Side tapped mounting style port opposite	161.25	170.60	177.30	260.85	375.35	522.30	636.20
Stroke adder	Add per inch of stroke	2.55	2.95	3.80	4.90	7.35	20.55	21.30
Special strokes	add for non-standard strokes	consult factory						
Mounting Bars	B1 for use with MV1 or MV2 – add price per pair	18.75	21.60	24.30	34.50	40.35	46.15	46.15
Integral Options	–C Cushions	N/A	N/A	61.00	65.25	74.90	114.15	140.35
	–V Viton® cylinder seals	8.75	11.90	11.90	13.60	15.80	17.90	24.30
	–P In-line top ports	4.45	4.40	4.40	4.45	6.10	8.20	Note 2
Toolbars	–T1, T5, T6, T7 (no additional cost)	–	–	–	–	–	–	–

Note 2 – "S3-1250" model only has "– P" option standard . Cylinder end port is **NOT** available on this model.

Step 2 – "S" Series Sensing Options	See step 2 page 83 ("L & S" Series)
--	-------------------------------------

Step 3 – "S" Series Tooling & Stop Options		S250	S375	S500	S750	S1000	S1250	S3-1250
Stop Collars See Note 1	–KE Stop collars extend only	\$20.40	\$21.55	\$23.35	\$26.10	\$29.80	\$33.50	\$33.50
	–KR Stop collars retract only	20.40	21.55	23.35	26.10	29.80	33.50	33.50
	–KB Stop collars extend & retract	40.75	43.10	46.65	52.25	59.60	67.00	67.00
Urethane Bumpers See Note 1	–UE Bumpers extend only, w/stop collars	22.40	24.25	26.55	30.25	35.30	40.50	40.50
	–UR Bumpers retract only, no stop collars	2.05	2.60	3.20	4.10	5.55	7.00	7.00
	–UB Bumpers both ends w/stop collars extend	24.50	26.80	29.70	34.30	40.85	47.50	47.50

Note 1 – "S" Series slides require a collar with a machined flat, adding cost over standard type clamp collars.

"SE" Series Linear Slides

Step 1 – "SE" Series Basic Slide Model		SE250	SE375	SE500	SE625	SE750	SE1000	SE1500
Base Price	–MS1 Standard mounting style	\$227.85	\$299.10	\$355.20	\$467.40	\$743.10	\$1009.55	\$2256.00
Mounting Bars	B1 for use with –MS1 – add price for pair	23.40	26.85	30.40	30.40	43.30	50.25	81.55
Stroke adder	add per inch of stroke	2.45	4.25	5.45	6.70	7.80	10.20	20.45
Special strokes	add for non-standard strokes	87.65	87.65	87.65	87.65	87.65	87.65	87.65
Toolbars	–T1, T3, T4 (no additional cost)	–	–	–	–	–	–	–
Integral Options	–D □ □ Dowel hole – add for each location shown in box(es)	33.85	35.05	36.20	36.20	40.85	40.85	45.85
	–H Hydraulic cylinder seals	52.60	52.60	52.60	52.60	52.60	52.60	105.20
	–V Viton cylinder seals	14.05	17.55	19.90	19.90	22.20	23.40	26.85
	–W Rulon® shaft bearings (no additional cost)	–	–	–	–	–	–	–
	–X Duralon® shaft bearings (no additional cost)	–	–	–	–	–	–	–
	–Y Hollow guide shafts	N/A	N/A	N/A	N/A	118.90	127.05	128.50
	Add per inch of stroke	N/A	N/A	N/A	N/A	9.05	8.75	6.10
	–Z Stainless steel guide shafts	–	–	–	–	–	–	–
	If hard chrome plated for use w/sleeve brgs, then NO added charge	64.00	67.45	75.40	89.65	98.10	134.05	268.45
	If 440C for use with linear ball bearings add	5.20	5.20	5.30	6.40	6.75	9.30	17.90
Then add per inch of stroke	–	–	–	–	–	–	–	
–S Grease fittings, side	32.70	33.85	35.05	35.05	39.70	39.70	39.70	
–T Grease fittings, top	29.20	30.40	31.55	31.55	36.20	36.20	36.20	

“SE” Series Linear Slides (continued)

Step 2 – “SE” Series Sensing Options		SE250	SE375	SE500	SE625	SE750	SE1000	SE1500
Prox Switch	–S000 No sensors desired	–	–	–	–	–	–	–
	–S01, S03, S05, S07 Prox switch – prewired							
	E Extend	\$141.65	\$144.00	\$156.00	\$158.90	\$161.55	\$167.10	\$169.45
	R Retract	132.05	134.40	156.00	158.90	161.55	167.10	169.45
	B Extend & retract	273.70	278.40	312.00	317.85	323.10	334.15	338.85
	M Extend, retract and mid-position	N/A	N/A	477.05	482.90	497.75	514.40	615.80
	–S02, S04, S06, S08 Quick disconnect prox with cordset							
	E Extend	181.15	183.40	195.40	198.30	200.95	205.85	208.80
	R Retract	171.40	173.75	195.40	198.30	200.95	205.85	208.80
	B Extend & retract	352.55	357.15	390.75	396.60	401.85	411.80	417.60
	M Extend, retract and mid-position	N/A	N/A	595.50	601.35	615.85	632.50	733.80
	–S12, S14, S16, S18 Quick disconnect prox without cordset							
	E Extend	148.90	151.05	163.05	166.00	168.60	173.60	176.50
	R Retract	139.10	141.45	163.05	166.00	168.60	173.60	176.50
	B Extend & retract	287.95	292.50	326.10	331.90	337.20	347.15	353.00
	M Extend, retract and mid-position	N/A	N/A	498.55	504.40	518.90	535.60	636.90
	–S40, S41, S42 Prox switch brackets & dogs only							
	E Extend	26.60	28.95	40.85	43.80	46.45	52.00	66.90
	R Retract	16.95	19.25	40.85	43.80	46.45	52.00	66.90
	B Extend & retract	43.55	48.20	81.80	87.65	92.95	104.00	133.20
M Extend, retract and mid-position	N/A	N/A	131.70	137.55	152.50	169.15	270.50	
Snap Action Mechanical Limit Switches	–S50							
	E Extend or R Retract	N/A	N/A	74.35	75.55	77.05	79.65	94.25
	B Extend and Retract	N/A	N/A	148.75	151.05	153.95	159.25	188.50
	M Extend, Retract and Mid-position	N/A	N/A	210.90	210.90	210.90	210.90	259.55
–S51								
E Extend or R Retract	N/A	N/A	56.65	58.15	59.35	62.20	76.85	
B Extend and Retract	N/A	N/A	113.35	116.30	118.60	124.45	153.65	
M Extend, Retract and Mid-position	N/A	N/A	169.15	173.55	177.05	184.15	227.15	
Air Pilot Valve, 3-way	–S60							
	E Extend or R Retract	N/A	N/A	50.45	53.40	55.95	61.55	76.15
B Extend and Retract	N/A	N/A	100.85	106.70	112.00	123.05	152.25	
Clamp-on Style “J” Sensors	–J70 Magnetic band with reed switch – prewired							
	E Extend or R Retract	N/A	49.85	55.75	55.75	55.75	55.75	68.45
	B Extend and Retract	N/A	82.25	88.05	88.05	88.05	88.05	107.65
	M Extend, Retract and Mid-position	N/A	N/A	120.45	120.45	120.45	120.45	146.85
	–J71 Mag. band w/quick disconnect reed switch w/cordset							
	E Extend or R Retract	N/A	80.05	85.85	85.85	85.85	85.85	106.00
	B Extend and Retract	N/A	142.60	148.40	148.40	148.40	148.40	182.75
	M Extend, Retract and Mid-position	N/A	N/A	210.90	210.90	210.90	210.90	259.55
	–J72, 74 Magnetic band w/electronic sensor – prewired							
	E Extend or R Retract	N/A	56.10	61.95	61.95	61.95	61.95	81.75
	B Extend and Retract	N/A	94.75	100.65	100.65	100.65	100.65	134.30
	M Extend, Retract and Mid-position	N/A	N/A	139.20	139.20	139.20	139.20	186.75
	–J73, 75 Mag. band w/electronic sensor w/quick disconn. cordset							
	E Extend or R Retract	N/A	86.30	92.15	92.15	92.15	92.15	119.30
	B Extend and Retract	N/A	155.05	160.85	160.85	160.85	160.85	209.35
	M Extend, Retract and Mid-position	N/A	N/A	229.60	229.60	229.60	229.60	299.50
Dovetail Style “E” Sensors	–E70 Magnetic band with reed switch – prewired							
	E Extend or R Retract	N/A	46.85	52.70	52.70	52.70	52.70	58.55
	B Extend and Retract	N/A	65.65	71.55	71.55	71.55	71.55	77.35
	M Extend, Retract and Mid-position	N/A	N/A	90.30	90.30	90.30	90.30	96.20
	–E71 Mag. band w/quick disconnect reed switch w/cordset							
	E Extend or R Retract	N/A	74.65	80.50	80.50	80.50	80.50	86.35
	B Extend and Retract	N/A	121.30	127.10	127.10	127.10	127.10	132.95
	M Extend, Retract and Mid-position	N/A	N/A	173.50	173.50	173.50	173.50	179.40
	–E72, 74 Magnetic band w/electronic sensor – prewired							
	E Extend or R Retract	48.35	51.90	57.75	57.75	57.75	57.75	63.60
	B Extend and Retract	72.15	75.70	81.60	81.60	81.60	81.60	87.40
	M Extend, Retract and Mid-position	N/A	N/A	105.40	105.40	105.40	105.40	111.25
	–E73, 75 Mag. band w/electronic sensor w/quick disconn. cordset							
	E Extend or R Retract	76.15	79.65	85.50	85.50	85.50	85.50	91.30
	B Extend and Retract	127.70	131.25	137.05	137.05	137.05	137.05	142.90
	M Extend, Retract and Mid-position	N/A	N/A	188.65	188.65	188.65	188.65	194.45
	–E76 Magnetic band with reed switch – prewired							
	E Extend or R Retract	N/A	46.10	51.95	51.95	51.95	51.95	57.80
	B Extend and Retract	N/A	64.15	70.00	70.00	70.00	70.00	75.85
	M Extend, Retract and Mid-position	N/A	N/A	87.95	87.95	87.95	87.95	93.85
–E77 Mag. band w/quick disconnect reed switch w/cordset								
E Extend or R Retract	N/A	73.95	79.75	79.75	79.75	79.75	85.60	
B Extend and Retract	N/A	119.80	125.60	125.60	125.60	125.60	131.45	
M Extend, Retract and Mid-position	N/A	N/A	171.45	171.45	171.45	171.45	177.30	
Mag. Band Only	–J800 Magnetic band only	N/A	17.55	23.40	23.40	23.40	23.40	29.20
	–E800 Magnetic band and dovetail mounting rail	24.55	28.05	33.85	33.85	33.85	33.85	39.70

“SE” Series Linear Slides (continued)

Step 2 – “SE” Series Sensor Options continued – 2 Meter Cordsets for 12mm Proximity Switches

Straight Cordsets	Part No. PCS01-2M for S12 option32.30	Part No. PCS03-2M for S14 option.....32.30	Part No. PCS05-2M for S16, S18 option 32.30
Rt. Angle Cordsets	Part No. PCS02-2M for S12 option32.30	Part No. PCS04-2M for S14 option.....32.30	Part No. PCS06-2M for S16, S18 option 32.30

Step 3 – “SE” Shock, Stop & Bumper Options		SE250	SE375	SE500	SE625	SE750	SE1000	SE1500
Shock Options Standard Location	–AE Ace shock, extend only	N/A	N/A	120.85	122.05	223.35	232.15	256.05
	–AR Ace shock, retract only	N/A	N/A	120.85	122.05	223.35	232.15	256.05
	–AB Ace shock, extend & retract	N/A	N/A	241.60	243.95	446.75	464.20	512.15
	–BE Enidine shock, extend only	N/A	N/A	120.85	122.05	223.35	232.15	256.05
	–BR Enidine shock, retract only	N/A	N/A	120.85	122.05	223.35	232.15	256.05
	–BB Enidine shock, extend & retract	N/A	N/A	241.60	243.95	446.75	464.20	512.15
	–CE Shock mounting package, extend only	N/A	N/A	54.95	56.05	70.10	78.85	102.85
	–CR Shock mounting package, retract only	N/A	N/A	54.95	56.05	70.10	78.85	102.85
Shock Options Alternate Location	–CB Shock mounting package, extend & retract	N/A	N/A	109.85	112.20	140.20	157.70	205.65
	–DR Ace shock, retract only	N/A	N/A	91.65	92.80	188.30	189.50	209.30
	–DB Ace shock, extend & retract	N/A	N/A	212.40	214.75	411.65	421.60	465.40
	–ER Enidine shock, retract only	N/A	N/A	91.65	92.80	188.30	189.50	209.30
	–EB Enidine shock, extend & retract	N/A	N/A	212.40	214.75	411.65	421.60	465.40
	–FR Shock mounting package, retract only	N/A	N/A	25.75	25.75	35.05	36.20	56.05
Dual Shock Options (SE1500 only)	–FB Shock mounting package, extend & retract	N/A	N/A	80.60	81.80	105.20	115.10	158.90
	–AXE Ace shock, extend only	N/A	N/A	N/A	N/A	N/A	N/A	512.15
	–AXR Ace shock, retract only	N/A	N/A	N/A	N/A	N/A	N/A	512.15
	–AXB Ace shock, extend & retract	N/A	N/A	N/A	N/A	N/A	N/A	1024.25
	–BXE Enidine shock, extend only	N/A	N/A	N/A	N/A	N/A	N/A	512.15
	–BXR Enidine shock, retract only	N/A	N/A	N/A	N/A	N/A	N/A	512.15
	–BXB Enidine shock, extend & retract	N/A	N/A	N/A	N/A	N/A	N/A	1024.25
	–CXE Shock mounting package, extend only	N/A	N/A	N/A	N/A	N/A	N/A	205.65
Dual Shock Options Alternate Location (SE1500 only)	–CXR Shock mounting package, retract only	N/A	N/A	N/A	N/A	N/A	N/A	205.65
	–CXB Shock mounting package, extend & retract	N/A	N/A	N/A	N/A	N/A	N/A	411.30
	–DXR Ace shock, retract only	N/A	N/A	N/A	N/A	N/A	N/A	418.70
	–DXB Ace shock, extend & retract	N/A	N/A	N/A	N/A	N/A	N/A	930.75
	–EXR Enidine shock, retract only	N/A	N/A	N/A	N/A	N/A	N/A	418.70
	–EXB Enidine shock, extend & retract	N/A	N/A	N/A	N/A	N/A	N/A	930.75
Stop Collars (see note 1)	–FXR Shock mounting package, retract only	N/A	N/A	N/A	N/A	N/A	N/A	112.20
	–FXB Shock mounting package, extend & retract	N/A	N/A	N/A	N/A	N/A	N/A	317.85
	–KE Stop collars extend only	19.25	10.50	12.00	13.45	15.50	18.10	28.70
Urethane Bumpers (see note 1)	–KR Stop collars retract only	19.25	10.50	12.00	13.45	15.50	18.10	28.70
	–KB Stop collars extend & retract	38.50	21.05	23.90	26.85	30.40	36.20	57.25
	–UE Bumpers extend only, w/stop collars	26.25	17.80	23.10	24.55	30.65	36.20	51.40
	–UR Bumpers retract only, no stop collars	7.00	7.35	11.15	11.15	15.20	18.10	22.80
	–UB Bumpers both ends w/stop collars extend	33.35	25.10	34.15	35.65	45.85	51.40	68.90
	–UKR Bumpers retract only with stop collars	26.25	17.80	23.10	24.55	30.65	36.20	51.40
	–UKB Bumpers both ends with stop collars both ends	52.60	35.65	46.15	49.10	61.35	72.50	102.85

Note 1 – SE250 model requires a collar with a machined flat, adding cost over other SE models.

“SE” Series Tandem Cylinder Option			SE250	SE375	SE500	SE625	SE750	SE1000	SE1500
Tandem Adder	Price for tandem cylinder option.	Secondary stroke cannot exceed primary stroke	N/A	N/A	261.70	261.70	341.50	411.30	500.05
	Add per inch of secondary stroke		N/A	N/A	4.40	4.40	5.55	7.00	15.20
Special Strokes	Add for non-standard primary stroke		N/A	N/A	87.65	87.65	87.65	87.65	87.65
	No extra charge for non-standard secondary stroke		N/A	N/A	–	–	–	–	–
Integral Option –H	Hydraulic cylinder seals		N/A	N/A	105.20	105.20	105.20	105.20	210.30

Note: Standard Shock Absorber Locations Are Available With Tandem Cylinder models; Alternate Shock Locations Are **NOT** Available.

“SE” Series Thin Parts Placer Transition Plates			
Part No.....Price	Part No.....Price	Part No.....Price	Part No.....Price
TPL01 30.40	TPL06 42.05	TPL11 56.05	TPL16 77.15
TPL02 32.70	TPL07 35.05	TPL12 56.05	TPL17 79.45
TPL03 33.85	TPL08 42.05	TPL13 63.10	TPL18 142.45
TPL04 35.05	TPL09 42.05	TPL14 70.10	TPL19 170.95
TPL05 35.05	TPL10 49.10	TPL15 70.10	

“SE” Series Multi-Power®, Hi-Thrust slides consult factory for pricing

"EZ" Series Linear Slides (See page 91 for pricing of "EZ" Tandem Models)

Step 1 – "EZ" Series Basic Slide Model		EZ250	EZ375	EZ500	EZ625	EZ750	EZ1000	EZ1500
Base Price	–MH1 Standard mounting style	\$262.35	\$342.65	\$407.80	\$538.05	\$641.45	\$885.10	\$1977.85
	–MH2 Tapped mounting holes style	279.55	361.95	429.65	559.65	665.75	921.05	2026.05
	–MF1 Front flange mounting style	297.65	390.85	462.10	592.10	701.65	956.95	2122.20
	–MF2 Rear flange mounting style	297.65	390.85	462.10	592.10	701.65	956.95	2122.20
	–MF3 Front & rear flange mounting style	333.00	439.05	516.50	646.10	761.85	1028.80	2266.45
	–MV1 Side tapped mounting style	315.75	439.05	489.00	619.25	731.70	993.15	2194.30
	–MV2 Side tapped w/ports on opposite side	330.10	455.70	508.25	638.50	754.55	1015.95	2218.25
Stroke Adder	Add per inch of stroke	2.75	5.20	6.30	7.80	9.05	11.65	23.40
Special Strokes	Add for non-standard strokes	87.65	87.65	87.65	87.65	87.65	87.65	87.65
Floating Rear Bearing Block Base Price	–MH1–FRBB Standard mounting style	N/A	450.15	521.15	653.75	765.30	N/A	2185.90
	–MH2–FRBB Tapped mounting holes style	N/A	469.40	543.05	675.35	789.60	1060.10	2234.10
Stroke Adder	–MV1–FRBB Side tapped mounting holes style	N/A	546.50	602.30	734.95	855.65	1132.20	2402.30
	–MV2–FRBB Side tapped w/ports opposite sides	N/A	563.20	738.45	753.70	878.35	1155.00	2426.30
Stroke Adder	Plus, add per inch of stroke	N/A	5.20	6.30	7.80	9.05	11.65	23.40
<i>Please specify stroke length & desired "Dimension D" on order. Stops, proximity & snap switches, and shocks are NOT available with Floating Rear Bearing Block Option.</i>								
Mounting Bars	B1 or use with MV1 or MV2 – add price per pair	25.10	28.95	33.85	33.85	43.30	57.90	93.75
Toolbars	–T1, T2, T3, T4 (no additional cost)	–	–	–	–	–	–	–
Integral Options	–D <input type="checkbox"/> <input type="checkbox"/> Dowel hole - add for each location shown in box(es)	33.85	35.05	36.20	36.20	40.85	40.85	45.85
	–H Hydraulic cylinder seals	52.60	52.60	52.60	52.60	52.60	52.60	105.20
	–V Viton cylinder seals	14.05	17.55	19.90	19.90	22.20	23.40	26.85
	–W Rulon® or –X Duralon® shaft bearings (no added charge)	–	–	–	–	–	–	–
	–Y Hollow guide shafts	N/A	N/A	N/A	N/A	125.60	149.00	150.70
	Add per inch of stroke	–	–	–	–	18.10	17.55	12.25
	–Z Stainless steel guide shafts If hard chrome plated for use w/sleeve brgs, then NO added charge If 440C for use with linear ball bearings add Then add per inch of stroke	– 64.25 10.25	– 70.40 10.25	– 78.30 10.50	– 87.35 12.85	– 102.85 13.45	– 158.30 18.75	– 322.25 35.90

Step 2 – "EZ" Series Sensing Options		EZ250	EZ375	EZ500	EZ625	EZ750	EZ1000	EZ1500	
Prox Switch	–S000 No sensors desired	–	–	–	–	–	–	–	
	–S01, S03, S05, S07 Prox switch prewired	E Extend	\$141.65	\$149.00	\$156.00	\$158.90	\$161.55	\$166.50	\$169.45
		R Retract	141.65	149.00	156.00	158.90	161.55	166.50	169.45
		B Both Extend & Retract	283.35	297.95	312.00	317.85	323.10	333.00	338.85
		M Extend, Retract & Mid-position	N/A	453.35	477.05	482.90	497.75	514.40	615.80
	–S02, S04, S06, S08 Quick disconnect prox switch with cordset	E Extend	181.05	188.35	195.40	198.30	200.95	205.85	208.80
		R Retract	181.05	188.35	204.40	206.80	200.95	205.85	208.80
		B Both Extend & Retract	362.10	376.70	399.80	405.05	401.85	411.80	417.60
		M Extend, Retract & Mid-position	N/A	571.45	604.25	611.85	615.85	632.50	733.80
	–S12, S14, S16, S18 Quick disconnect prox switch without cordset	E Extend	148.75	156.05	163.05	166.00	168.60	173.60	176.50
		R Retract	148.75	156.05	172.10	174.40	168.60	173.60	176.50
		B Extend & retract	297.50	312.10	335.10	340.40	337.20	347.15	353.00
		M Extend, retract and mid-position	N/A	474.50	507.30	514.90	518.90	567.10	636.90
	–S40, S41, S42 Prox bracket and actuator dogs only	E Extend	26.60	33.85	40.85	43.80	46.45	52.00	66.60
		R Retract	26.60	33.85	40.85	43.80	46.45	52.00	66.60
B Both Extend & Retract		53.15	67.75	81.80	96.15	92.95	104.00	133.20	
M Extend, Retract & Mid-position		N/A	108.05	131.70	137.55	152.50	169.15	270.50	
–S45, S46, S47 Alternate location Prox bracket and actuator dogs only	E Extend	N/A	N/A	40.85	43.80	N/A	N/A	N/A	
	R Retract	N/A	N/A	49.90	52.30	N/A	N/A	N/A	
	B Both Extend & Retract	N/A	N/A	90.85	96.15	N/A	N/A	N/A	
	M Extend, Retract & Mid-position	N/A	N/A	140.75	148.40	N/A	N/A	N/A	
Snap Action Limit Switches	–S50	E Extend or R Retract	N/A	N/A	74.35	75.55	77.05	79.15	94.25
		B Both Extend and Retract	N/A	N/A	148.75	151.05	153.95	159.25	188.50
	–S51	E Extend or R Retract	N/A	N/A	56.65	58.15	59.35	62.20	76.85
		B Both Extend and Retract	N/A	N/A	113.35	116.30	118.60	124.45	153.65
Air Pilot Valve, 3-way	–S60	E Extend or R Retract	N/A	N/A	50.45	53.40	55.95	61.55	76.15
		B Both Extend and Retract	N/A	N/A	100.85	106.70	112.00	123.05	152.25
Clamp-on Style "J" Sensors	–J70 Magnetic band with reed switch prewired	E Extend or R Retract	N/A	49.85	55.75	55.75	55.75	55.75	68.45
		B Extend and Retract	N/A	82.25	88.05	88.05	88.05	88.05	107.65
		M Extend, Retract and Mid-position	N/A	114.60	120.45	120.45	120.45	120.45	146.85
	–J71 Magnetic band with reed switch w/quick disc. cordset	E Extend or R Retract	N/A	80.05	85.85	85.85	85.85	85.85	106.00
		B Extend and Retract	N/A	142.60	148.40	148.40	148.40	148.40	182.75
		M Extend, Retract and Mid-position	N/A	205.05	210.90	210.90	210.90	210.90	259.55
	–J72, 74 Magnetic band electronic sensor prewired	E Extend or R Retract	52.65	56.10	61.95	61.95	61.95	61.95	81.75
		B Extend and Retract	91.20	94.75	100.65	100.65	100.65	100.65	134.30
		M Extend, Retract and Mid-position	129.90	133.40	139.20	139.20	139.20	139.20	186.75
	–J73, 75 Mag. band electronic sensor w/quick disc. cordset	E Extend or R Retract	82.80	86.30	92.15	92.15	92.15	92.15	119.30
B Extend and Retract		151.55	155.05	160.85	160.85	160.85	160.85	209.35	
	M Extend, Retract and Mid-position	220.30	223.80	229.60	229.60	229.60	229.60	229.50	

Step 2 – “EZ” Series Sensing Options			EZ250	EZ375	EZ500	EZ625	EZ750	EZ1000	EZ1500
Dovetail Style “E” Sensors	–E70 Magnetic band with reed switch prewired	E Extend or R Retract	N/A	\$46.85	\$52.70	\$52.70	\$52.70	\$52.70	\$58.55
		B Extend and Retract	N/A	65.65	71.55	71.55	71.55	71.55	77.35
		M Extend, Retract and Mid-position	N/A	84.50	90.30	90.30	90.30	90.30	96.20
	–E71 Magnetic band with reed switch w/quick disc. cordset	E Extend or R Retract	N/A	74.65	80.50	80.50	80.50	80.50	86.35
		B Extend and Retract	N/A	121.30	127.10	127.10	127.10	127.10	132.95
		M Extend, Retract and Mid-position	N/A	167.65	173.50	173.50	173.50	173.50	179.40
	–E72, 74 Mag. band electronic sensor prewired	E Extend or R Retract	48.35	51.90	57.75	57.75	57.75	57.75	63.60
		B Extend and Retract	72.15	75.70	81.60	81.60	81.60	81.60	87.40
		M Extend, Retract and Mid-position	N/A	99.55	105.40	105.40	105.40	105.40	111.25
	–E73, 75 Mag. band electronic sensor w/quick disc. cordset	E Extend or R Retract	76.15	79.65	85.50	85.50	85.50	85.50	91.30
		B Extend and Retract	127.70	131.25	137.05	137.05	137.05	137.05	142.90
		M Extend, Retract and Mid-position	N/A	182.80	188.65	188.65	188.65	188.65	194.45
–E76 Magnetic band with reed switch prewired	E Extend or R Retract	N/A	46.10	51.95	51.95	51.95	51.95	57.80	
	B Extend and Retract	N/A	64.15	70.00	70.00	70.00	70.00	75.85	
	M Extend, Retract and Mid-position	N/A	82.10	87.95	87.95	87.95	87.95	93.85	
–E77 Magnetic band with reed switch w/quick disc. cordset	E Extend or R Retract	N/A	73.95	79.75	79.75	79.75	79.75	85.60	
	B Extend and Retract	N/A	119.80	125.60	125.60	125.60	125.60	131.45	
	M Extend, Retract and Mid-position	N/A	165.60	171.45	171.45	171.45	171.45	177.30	
Mag. Band Only	–J800 Magnetic band only		14.05	17.55	23.40	23.40	23.40	23.40	29.20
	–E800 Magnetic band and dovetail mounting rail		24.55	28.05	33.85	33.85	33.85	33.85	39.70

Step 2 – “EZ” Series Sensor Options continued – 2 Meter Cordsets for 12mm Proximity Switches – See chart on page 89

Step 3 – “EZ” Series Tooling, Stop & Shock Options			EZ250	EZ375	EZ500	EZ625	EZ750	EZ1000	EZ1500
Tooling Options	–RC Rear clampbar		\$26.25	\$34.50	\$40.85	\$53.50	\$59.00	\$77.15	\$188.70
	–RT Additional rear toolbar		32.40	41.45	50.55	62.20	72.10	96.95	213.00
	–BL Tall blocks		61.65	89.65	117.75	152.80	184.60	247.75	545.05
	–CS Tall blocks with center support		N/A	N/A	222.90	258.00	329.85	394.10	719.45
	–PL Toolplate		87.10	119.80	157.20	204.20	246.25	329.85	723.35
	plus – add per inch of stroke		2.35	2.95	3.80	3.80	5.85	9.30	15.20
	–PS Toolplate with center support		N/A	N/A	262.35	309.35	391.40	476.15	899.70
	plus – add per inch of stroke		–	–	3.80	3.80	5.85	9.30	15.20
	–TB Twin beam overhead support option package		N/A	N/A	N/A	405.15	480.55	586.85	1028.20
	plus – add per inch of stroke		N/A	N/A	N/A	2.60	3.20	3.80	5.55
	–SB Single beam overhead support option package		N/A	N/A	N/A	345.60	400.45	507.70	687.90
	plus – add per inch of stroke		N/A	N/A	N/A	1.75	2.35	2.95	4.10
–VB Vertical shaft mounting blocks – add price per pair		103.70	111.90	135.55	170.90	220.85	289.50	604.90	
Mounting Bars	B2 for use with VB shaft mounting blocks – add price per pair		30.10	35.05	39.70	39.70	54.30	69.80	114.20
Stop Options	–00 No stops		–	–	–	–	–	–	–
	–01 Type 1 adjustable stops		7.60	8.75	11.65	11.65	18.75	25.10	36.20
	–U1 Type 1 adjustable stops w/Urethane bumpers		22.80	23.90	31.00	31.00	40.35	49.40	65.15
	–02 Type 2 adjustable stops		24.55	28.05	32.15	32.15	42.65	53.75	74.80
	–03 Type 3 adjustable stops		33.85	38.50	40.85	40.85	48.20	57.90	77.15
Shock Options Standard Location	–AE Ace shock, extend only		N/A	101.55	96.85	99.80	197.65	200.25	202.60
	–AR Ace shock, retract only		N/A	101.55	120.85	123.50	223.65	232.15	256.05
	–AB Ace shock, extend & retract		N/A	203.10	217.70	223.25	421.55	432.40	458.65
	–BE Enidine shock, extend only		N/A	101.55	96.85	99.80	197.65	200.25	202.60
	–BR Enidine shock, retract only		N/A	101.55	120.85	123.50	223.65	232.15	256.05
	–BB Enidine shock, extend & retract		N/A	203.10	217.70	223.25	421.25	432.40	458.65
	–CE Shock mounting package, extend only		N/A	35.65	31.00	33.85	44.40	47.05	49.40
	–CR Shock mounting package, retract only		N/A	35.65	54.95	57.50	70.40	78.85	102.85
	–CB Shock mounting package, extend & retract		N/A	71.25	85.85	91.45	114.80	125.90	152.15
	Shock Options Alternate Location	–DE Ace shock, extend only		N/A	96.85	96.85	99.80	197.65	200.25
–DR Ace shock, retract only			N/A	96.85	96.85	99.80	197.65	200.25	202.60
–DB Ace shock, extend & retract			N/A	193.70	193.70	199.20	395.30	400.55	405.20
–EE Enidine shock, extend only			N/A	96.85	96.85	99.80	197.65	200.25	202.60
–ER Enidine shock, retract only			N/A	96.85	96.85	99.80	197.65	200.25	202.60
–EB Enidine shock, extend & retract			N/A	193.70	193.70	199.60	395.30	400.55	405.20
–FE Shock mounting package, extend only			N/A	31.00	31.00	33.85	44.40	47.05	49.40
–FR Shock mounting package, retract only			N/A	31.00	31.00	33.85	44.40	47.05	49.40
–FB Shock mounting package, extend & retract		N/A	61.90	61.90	67.75	88.80	94.05	98.75	
Dual Shock Options	–AXE, AXR, AXB, BXE, BXR, BXB, CXE, CXR, CXB		Double the corresponding A, B & C prices above						
Options: EZ1500 only	–DXE, DXR, DXB, EXE, EXR, EXB, FXE, FXR, FXB		Double the corresponding D, E & F prices above						

“EZ” Series – Thin Parts Placer Transition Plates

TPL38/25–(stroke) 53.15	TPL62/25–(stroke) 53.15	TPL75/38–(stroke) 84.15	TPL100/50–(stroke) 114.50	TPL150/75–(stroke) 144.35
Add per inch Vert. stroke 1.30	Add per inch Vert. stroke. ... 1.30	Add per inch Vert. stroke. ... 1.45	Add per inch Vert. stroke. ... 2.95	Add per inch Vert. stroke. ... 3.85
TPL50/25–(stroke) 53.50	TPL62/38–(stroke) 60.20	TPL75/50–(stroke) 84.15	TPL100/62–(stroke) 114.50	
Add per inch Vert. stroke..... 1.30	Add per inch Vert. stroke. ... 1.45	Add per inch Vert. stroke. ... 1.45	Add per inch Vert. stroke. ... 2.60	
TPL50/38–(stroke) 57.90	TPL62/50–(stroke) 72.10	TPL75/62–(stroke) 114.20	TPL100/75–(stroke) 138.20	
Add per inch Vert. stroke..... 1.45	Add per inch Vert. stroke. ... 2.05	Add per inch Vert. stroke. ... 2.60	Add per inch Vert. stroke. ... 3.20	

"EZF" Series Pick & Place Units

Step 1 – "EZF" Series Pick & Place Units		EZP5025	EZP7550
Base Price	–MH1 Standard mounting style	\$795.10	\$1049.25
	–MH2 Tapped mounting holes style	817.00	1073.55
	–MF1 or –MF2 Front or rear flange mounting style	849.45	1109.50
	–MF3 Both Front and Rear flange mounting style	903.20	1169.60
	–MV1 Side tapped mounting style	876.35	1139.50
	–MV2 Side tapped w/ports on opposite side	895.60	1162.35
Mounting Bars	B1 for use with MV1 or MV2 – add price per pair	33.85	43.30
Stroke Adder	Per inch of horizontal stroke (H)	6.30	9.05
	Per inch of vertical stroke (V)	6.30	6.30
	Then, if (H) horizontal stroke is non-standard add additional	87.65	87.65
	Also, if (V) vertical stroke is non-standard add additional	87.65	87.65
Toolbars	T1 (no additional cost)	–	–
	T10 Transition to SPG 100 Gripper	58.40	N/A
	T20 Transition to SPG 200 Gripper	58.40	58.40
	T30 Transition to SPG 300 Gripper	58.40	58.40
Integral Options	–D □□ Dowel hole - add for each location shown in box(es)	36.20	40.85
	–V Viton cylinder seals	42.05	42.05
	–H Hydraulic cylinder seals	105.20	105.20
	–Y Hollow guide shafts horizontal motion (H)	N/A	125.60
	Add per inch of horizontal stroke	N/A	18.10
	–Z Stainless steel guide shafts		
	If hard chrome plated for use w/sleeve brgs, then NO added charge	–	–
	If 440C for use with linear ball bearings add	142.60	181.10
	Then add per inch of horizontal stroke (H)	10.50	13.45
	Then add per inch of vertical stroke (V)	10.25	10.50
–W Rulon® shaft bearings (no additional cost)	–	–	
–X Duralon® shaft bearings (no additional cost)	–	–	

Step 2 – "EZ" & "EZF" Series Sensor Options continued – 2 Meter Cordsets for 12mm Proximity Switches		
Straight Cordsets	Part #	Price
for S12 option	PCS01-2M	32.30
for S14 option	PCS03-2M	32.30
for S16, S18 option	PCS05-2M	32.30
Rt. Angle Cordsets	Part #	Price
for S12 option	PCS02-2M	32.30
for S14 option	PCS04-2M	32.30
for S16, S18 option	PCS06-2M	32.30

***Note:**
Mid-position Prox Switch is **NOT** available on the vertical motion of EZP5025

Step 2 – "EZF" Pick & Place Sensor Options		EZ5025		EZP7550		
		Horiz.	Vert.	Horiz.	Vert.	
Prox Switch	–S000 No sensors desired	–	–	–	–	
	–S01, S03, S05, S07 Prox switch prewired	E Extend	\$156.00	\$189.35	\$161.55	\$156.00
		R Retract	156.00	161.25	161.55	156.00
		B Both Extend and Retract	312.00	350.55	323.10	312.00
		M* Extend, Retract and Mid-position	477.05	N/A *note	497.75	477.05
	–S02, S04, S06, S08 Quick disconnect prox with cordset	E Extend	195.40	228.70	200.95	195.40
		R Retract	204.40	200.65	200.95	204.40
		B Both Extend and Retract	399.80	429.30	401.85	399.80
		M* Extend, Retract and Mid-position	604.25	N/A *note	615.85	604.25
	–S12, S14, S16, S18 Quick disconnect prox switch without cordset	E Extend	163.05	196.35	168.60	163.05
		R Retract	172.10	168.30	168.60	172.10
		B Extend & retract	335.10	364.70	337.20	335.10
		M Extend, retract and mid-position	507.30	N/A	518.90	507.30
	–S40, S41, S42 Prox brackets and dogs only	E Extend	40.85	74.20	46.45	40.85
		R Retract	40.85	46.15	46.45	40.85
		B Both Extend and Retract	81.80	120.30	92.95	81.80
M* Extend, Retract and Mid-position		131.70	N/A *note	152.50	131.70	
–S45, S46, S47 Alternate location Prox brackets and dogs only	E Extend	40.85	N/A	N/A	40.85	
	R Retract	49.90	N/A	N/A	49.90	
	B Both Extend and Retract	90.85	N/A	N/A	90.85	
	M* Extend, Retract and Mid-position	140.75	N/A *note	N/A	140.75	
Snap Action Limit Switches	–S50	E Extend	74.35	79.65	77.05	74.35
		R Retract	74.35	77.05	77.05	74.35
		B Both Extend and Retract	151.05	156.60	153.95	148.75
	–S51	E Extend	56.65	62.20	59.35	56.65
		R Retract	56.65	59.35	59.35	56.65
		B Both Extend and Retract	113.35	121.50	118.60	113.35
Air Pilot Valve, 3-way	–S60	E Extend	50.45	55.95	55.95	50.45
		R Retract	50.45	53.00	55.95	50.45
		B Both Extend and Retract	100.85	109.05	112.00	100.85
		E Extend or R Retract	55.75	102.20	55.75	55.75
Clamp-on Style "J" Sensors	–J70 Magnetic band with reed switch prewired	B Both Extend and Retract	88.05	134.55	88.05	88.05
		M Extend, Retract and Mid-position	120.45	N/A *note	120.45	120.45
		E Extend or R Retract	85.85	132.35	85.85	85.85
	–J71 Magnetic band with reed switch w/quick disc. cordset	B Both Extend and Retract	148.40	194.80	148.40	148.40
		M Extend, Retract and Mid-position	210.90	N/A *note	210.90	210.90
	–J72, J74 Mag. band electronic sensor prewired	E Extend or R Retract	61.95	108.45	61.95	61.95
		B Both Extend and Retract	100.65	147.05	100.65	100.65
		M* Extend, Retract and Mid-position	139.20	N/A *note	139.20	139.20

"EZP" Series Pick & Place Units

Step 2 – "EZP" Pick & Place Sensor Options (continued)			EZP5025		EZP7550	
			Horiz	Vert	Horiz	Vert
Clamp-on Style "J" Sensors continued	-J73, J75 Mag. band electronic sensor with quick disconnect cordset	E Extend or R Retract	\$92.15	\$138.55	\$92.15	\$92.15
		B Both Extend and Retract	160.85	207.35	160.85	160.85
		M* Extend, Retract and Mid-position	229.60	N/A *note	229.60	229.60
Dovetail Style "E" Sensors	-E70 Magnetic band with reed switch prewired	E Extend or R Retract	52.70	99.15	52.70	52.70
		B Extend and Retract	71.55	117.95	71.55	71.55
		M Extend, Retract and Mid-position	90.30	N/A *note	90.30	90.30
	-E71 Magnetic band with reed switch w/quick disc. cordset	E Extend or R Retract	80.50	126.95	80.50	80.50
		B Extend and Retract	127.10	173.60	127.10	127.10
		M Extend, Retract and Mid-position	173.50	N/A *note	173.50	173.50
	-E72, 74 Mag. band electronic sensor prewired	E Extend or R Retract	57.75	104.15	57.75	57.75
		B Extend and Retract	81.60	128.05	81.60	81.60
		M Extend, Retract and Mid-position	105.40	N/A *note	105.40	105.40
	-E73, 75 Mag. band electronic sensor w/quick disc. cordset	E Extend or R Retract	85.50	131.90	85.50	85.50
		B Extend and Retract	137.05	183.50	137.05	137.05
		M Extend, Retract and Mid-position	188.65	N/A *note	188.65	188.65
-E76 Magnetic band with reed switch prewired	E Extend or R Retract	51.95	98.40	51.95	51.95	
	B Extend and Retract	70.00	116.45	70.00	70.00	
	M Extend, Retract and Mid-position	87.95	N/A *note	87.95	87.95	
-E77 Magnetic band with reed switch w/quick disc. cordset	E Extend or R Retract	79.75	126.15	79.75	79.75	
	B Extend and Retract	125.60	172.05	125.60	125.60	
	M Extend, Retract and Mid-position	171.45	N/A *note	171.45	171.45	
Mag. Band Only	-J800 Magnetic band only		23.40	69.80	23.40	23.40
	-E800 Magnetic band and Dovetail Mounting Rail		33.85	80.35	33.85	33.85

Step 3 – "EZP" Series Tooling, Stop & Shock Options		EZP5025	EZP7550	
Tooling	-RC Rear clampbar	\$73.30	\$99.90	
	-BL Tooling plate mtg. blocks only on vertical motion only	N/A	176.70	
	-PL Tooling mtg. plate option on vertical motion only	N/A	216.15	
	Add per inch of vertical motion stroke	N/A	3.80	
Horizontal Adjustable Stops	-H00 No stops desired	-	-	
	-H01 Type 1 adjustable stops	11.65	18.75	
	-HU1 Type 1 stops w/Urethane bumpers	31.00	40.35	
	-H02 Type 2 adjustable stops	32.15	42.65	
Horizontal Shocks	-N0 shocks desired	-	-	
	-AE Ace Shocks, extend only (complete w/mounting package)	96.85	197.65	
	-AR Ace Shocks, retract only (complete w/mounting package)	120.85	223.65	
	-AB Ace Shocks, extend & retract (complete w/mtg. pkg.)	217.70	421.25	
	-BE Enidine Shocks, extend only (complete w/mounting pkg.)	96.85	197.65	
	-BR Enidine Shocks, retract only (complete w/mounting pkg.)	120.85	223.65	
	-BB Enidine Shocks, extend & retract (complete w/mtg. pkg.)	217.70	421.25	
	-CE Shock mounting package, extend only	31.00	44.40	
	-CR Shock mounting package	54.95	70.40	
	-CB Shock mounting package, extend & retract	85.85	114.80	
	Vertical Adjustable Stops	-V00 No stops desired -	-	-
		-V01 Type 1 adjustable stops	N/A	11.65
-VU1 Type 1 stops w/Urethane bumpers		N/A	31.00	
-V02 Type 2 adjustable stops		N/A	32.15	
-V03 Type 3 adjustable stops used w/"BL" or "PL" only		N/A	40.85	
-V04 Type 3 stops with stop bolt at one end only		17.25	N/A	
Vertical Shocks	-N0 No stops desired	-	-	
	-AE Ace Shocks, extend only (complete w/mounting package)	103.30	96.85	
	-AR Ace Shocks, retract only (complete w/mounting package)	143.00	120.85	
	-AB Ace Shocks, extend & retract (complete w/mtg. pkg.)	246.30	217.70	
	-BE Enidine Shocks, extend only (complete w/mounting pkg.)	103.30	96.85	
	-BR Enidine Shocks, retract only (complete w/mounting pkg.)	143.00	120.85	
	-BB Enidine Shocks, extend & retract (complete w/mtg. pkg.)	246.30	217.70	
	-CE Shock mounting package, extend only	37.40	31.00	
	-CR Shock mounting package	77.15	54.95	
	-CB Shock mounting package, extend & retract	114.50	85.85	
	-DE Ace Shocks, extend only (complete w/mounting package)	N/A	96.85	
	-DR Ace Shocks, retract only (complete w/mounting package)	N/A	96.85	
	-DB Ace Shocks, extend & retract (complete w/mtg. pkg.)	N/A	193.70	
	-EE Enidine Shocks, extend only (complete w/mounting pkg.)	N/A	96.85	
	-ER Enidine Shocks, retract only (complete w/mounting pkg.)	N/A	96.85	
	-EB Enidine Shocks, extend & retract (complete w/mtg. pkg.)	N/A	193.70	
	-FE Shock mounting package, extend only	N/A	31.00	
	-FR Shock mounting package	N/A	31.00	
-FB Shock mounting package, extend & retract	N/A	61.90		

Step 2 – "EZP" Series Sensor Options continued – 2 Meter Cordsets for 12mm Proximity Switches		
Straight Cordsets	Part #	Price
for S12 option	PCS01-2M	32.30
for S14 option	PCS03-2M	32.30
for S16, S18 option	PCS05-2M	32.30
Rt. Angle Cordsets	Part #	Price
for S12 option	PCS02-2M	32.30
for S14 option	PCS04-2M	32.30
for S16, S18 option	PCS06-2M	32.30

See page 92 for Pricing of "EZP" Pick & Place Tandem Cylinder Models

"EZ" Tandem Linear Slides

Step 1 – "EZ" Tandem Basic Slide Model		EZ375	EZ500	EZ625	EZ750	EZ1000	EZ1500
Base Price	-MH1 Standard mounting style	\$342.65	\$407.80	\$538.55	\$641.45	\$885.10	\$1977.85
	-MH2 Tapped mounting holes style	361.95	429.65	559.65	665.75	921.05	2026.05
	-MF1 Front flange mounting style	390.85	462.10	592.10	701.65	956.95	2122.20
	-MF2 Rear flange mounting style	390.85	462.10	592.10	701.65	956.95	2122.20
	-MF3 Front & rear flange mounting style	439.05	516.50	646.10	761.85	1028.80	2266.45
	-MV1 Side tapped mounting style	439.05	489.00	619.25	731.70	993.15	2194.30
	-MV2 Side tapped w/ports on opposite side	455.70	508.25	638.50	754.55	1015.95	2218.25
Stroke Adder	Add per inch of primary stroke	5.20	6.30	7.80	9.05	11.65	23.40
Tandem Adder	Price for tandem cylinder option	252.40	261.70	297.40	341.50	411.30	901.75
	Add per inch of secondary stroke	3.20	4.40	4.40	5.55	7.00	15.20
Special Strokes	Add for non-standard primary stroke	87.65	87.65	87.65	87.65	87.65	87.65
	No added charge for non-standard secondary stroke	-	-	-	-	-	-
Mounting Bars	B1 for use with MV1 or MV2 – add price per pair	28.95	33.85	33.85	43.30	57.90	93.75
Toolbars	-T1, T2, T3, T4 (no added charge)	N/C	N/C	N/C	N/C	N/C	N/C
Integral Options	-D <input type="checkbox"/> <input type="checkbox"/> Dowel hole - add for each location shown in box(es)	35.05	36.20	36.20	40.85	40.85	45.85
	-H Hydraulic cylinder seals	105.20	105.20	105.20	105.20	105.20	210.30
	-V Viton cylinder seals	35.05	39.70	39.70	44.40	46.75	53.75
	-W Rulon® shaft bearings (no added charge)	-	-	-	-	-	-
	-X Duralon® shaft bearings (no added charge)	-	-	-	-	-	-
	-Y Hollow guide shafts – add price then add price per inch of primary stroke	N/A -	N/A -	N/A -	125.60 18.10	149.00 17.55	150.70 12.25
	-Z Stainless steel guide shafts If hard chrome plated for use w/sleeve brgs, then NO added charge If 440C for use with linear ball bearings add then add price per inch of primary stroke	- 70.40 10.25	- 78.30 10.50	- 87.35 12.85	- 102.85 13.45	- 158.30 18.75	- 322.25 35.90

Step 2 – "EZ" Tandem Sensor Options	See "EZ" Series Step #2 prices pages 87 & 88
--	--

Step 3 – "EZ" Tandem Tooling Options		EZ375	EZ500	EZ625	EZ750	EZ1000	EZ1500
-RC Rear clampbar– add price, then add price per inch of secondary stroke (Table 1 below)		34.50	40.85	53.50	59.00	77.15	188.70
-RT Additional rear toolbar– add price, then add price per inch of secondary stroke (Table 1 below)		41.45	50.55	62.20	72.10	96.95	213.00
-BL Tall blocks	(Front & rear mounting blocks only) add price	89.65	117.75	152.80	184.60	247.75	545.05
	add per inch of secondary stroke (Table 1 below)	Table 1	Table 1	Table 1	Table 1	Table 1	Table 1
-CS Tall blocks with center support – add price	add price	N/A	222.90	258.00	329.85	394.10	719.45
	add per inch of secondary stroke (Table 1 below)	Table 1	Table 1	Table 1	Table 1	Table 1	Table 1
-PL Toolplate –	add price	119.80	157.20	204.20	246.25	329.85	725.35
	add per inch of primary stroke [†]	2.95 [†]	3.80 [†]	3.80 [†]	5.85 [†]	9.30 [†]	15.20 [†]
	then add per inch of secondary stroke [†]	1.45 [†]	1.95 [†]	1.95 [†]	2.95 [†]	4.65 [†]	7.60 [†]
	then add per inch of secondary stroke (Table 1 below)	Table 1	Table 1	Table 1	Table 1	Table 1	Table 1
-PS Toolplate with center support – add price	add price	N/A	262.35	309.35	391.40	476.15	899.70
	add per inch of primary stroke [†]	N/A	3.80 [†]	3.80 [†]	5.85 [†]	9.30 [†]	15.20 [†]
	then add per inch of secondary stroke [†]	N/A	1.95 [†]	1.95 [†]	2.95 [†]	4.65 [†]	7.60 [†]
	then add per inch of secondary stroke (Table 1 below)	N/A	Table 1	Table 1	Table 1	Table 1	Table 1
-TB Twin beam overhead support option package – add price	add price	N/A	N/A	405.15	480.55	586.85	1028.20
	add per inch of primary stroke [†]	N/A	N/A	2.60 [†]	3.20 ^{††}	3.80 [†]	5.55 [†]
	then add per inch of secondary stroke [†]	N/A	N/A	1.35 [†]	1.60 [†]	1.95 [†]	2.85 [†]
	then add per inch of secondary stroke (Table 1 below)	N/A	N/A	Table 1	Table 1	Table 1	Table 1
-SB Single beam overhead support option package	add price	N/A	N/A	345.60	400.45	507.70	687.90
	add per inch of primary stroke [†]	N/A	N/A	1.75 [†]	2.35 [†]	2.95 [†]	4.10 [†]
	then add per inch of secondary stroke [†]	N/A	N/A	0.90 [†]	1.20 [†]	1.45 [†]	2.05 [†]
	then add per inch of secondary stroke (Table 1 below)	N/A	N/A	Table 1	Table 1	Table 1	Table 1
-VB Vertical shaft mounting blocks– add price, then add per inch of secondary stroke (Table 1)		111.90	135.55	170.90	220.85	289.50	604.90
B2 for use with VB shaft mounting blocks – add price per pair		35.05	39.70	39.70	54.30	69.80	114.20

Step 3 Continued – "EZ" Tandem Adjustable Stop & Shock Options	See "EZ" Series step #3 prices on page 88
---	---

Note [†] – Covers cost of additional plate or beam.

TABLE 1 – Cost of additional guide shaft length for material you selected		EZ375	EZ500	EZ625	EZ750	EZ1000	EZ1500
Standard	Case hardened guide shafts	2.45	2.60	3.20	4.10	5.45	8.95
-Y	Hollow guide shafts	N/A	N/A	N/A	13.15	14.05	15.20
-Z	Stainless steel	7.20	7.40	9.60	10.45	14.75	26.85

“EZP” Tandem Cylinder Pick & Place Units

Step 1 – “EZP” Tandem Cylinder Pick & Place Units		EZP5025		EZP7550		EZP7550		EZP7550	
		Tandem on Horiz.		Tandem on Horiz.		Tandem on Vert.		Tandem on Both	
Base Price	–MH1 Standard mounting style	1056.90		1390.75		1311.00		1652.45	
	–MH2 Tapped mounting holes style	1078.75		1414.95		1335.20		1676.70	
	–MF1 or –MF2 Front or rear flange mounting style	1111.20		1450.85		1371.15		1712.65	
	–MF3 Both Front and Rear flange mounting style	1164.95		1511.10		1474.15		1772.85	
	–MV1 Side tapped mounting style	1138.05		1481.00		1401.20		1742.70	
	–MV2 Side tapped w/ports on opposite side	1157.30		1503.85		1424.05		1765.20	
Stroke Adder	Per inch of primary stroke for the horizontal (H) unit	6.30		9.05		9.05		9.05	
	Per inch of primary stroke for the vertical (V) unit	6.30		6.30		6.30		6.30	
	Per inch of secondary stroke for the horizontal (H) unit	4.40		5.55		–		5.55	
	Per inch of secondary stroke for the vertical (V) unit	–		–		4.40		4.40	
Special Strokes	Add for non-standard (primary) stroke	Hor. 87.65	Vert. 87.65	Hor. 87.65	Vert. 87.65	Hor. 87.65	Vert. 87.65	Hor. 87.65	Vert. 87.65
	No added cost for non-standard secondary strokes	–	N/A.	–	–	–	–	–	–
Toolbars	No added cost	–		–		–		–	
Mounting Bars	B1 for use with MV1 or MV2 – add price per pair	33.85		43.30		43.30		43.30	
	–D <input type="checkbox"/> <input type="checkbox"/> Dowel Hole • add for each location shown in box(es)	36.20		40.85		40.85		40.85	
	–H Hydraulic cylinder seals	157.70		157.70		157.70		210.30	
	–V Viton cylinder seals	81.80		83.00		78.30		119.20	
	–W Rulon® or –X Duralon® shaft bearings (no added cost)	–		–		–		–	
	–Y Hollow guide shafts, horizontal only – add price then add price per inch of horizontal stroke	N/A		N/A		125.60		125.60	
		N/A		N/A		18.10		18.10	
	–Z Stainless steel guide shafts	–		–		–		–	
	If hard chrome plated for use w/sleeve brgs, then NO added charge	–		–		–		–	
	If 440C for use with linear ball bearings add then add price per inch of horizontal primary stroke	142.60		181.10		181.10		181.10	
then add price per inch of horizontal secondary stroke	10.50		13.45		13.45		13.45		
then add price per inch of vertical primary stroke	10.50		13.45		1.20		13.45		
then add price per inch of vertical secondary stroke	10.25		10.50		10.50		10.50		
	–		–		10.50		10.50		

Step 2 – “EZP” Tandem Cylinder Sensor Options See “EZP” step #2 prices pages 89 & 90

Step 3 – “EZP” Tandem Tooling Options		EZP5025		EZP7550		EZP7550		EZP7550	
		Tandem on Horiz.		Tandem on Horiz.		Tandem on Vert.		Tandem on Both	
–RC	Rear clampbar package – add price,	73.30		99.90		99.90		99.90	
	then add per inch price of secondary stroke on horizontal	Table 2		Table 3		–		Table 3	
	then add per inch price of secondary stroke on vertical	–		–		Table 2		Table 2	
–BL	Tall blocks package on vertical (Includes RC on horizontal) – add price,	N/A		176.70		176.70		176.70	
	then add per inch price of secondary stroke on horizontal	–		Table 3		–		Table 3	
	then add per inch price of secondary stroke on vertical	–		–		Table 2		Table 2	
–PL	Toolplate– add price,	N/A		216.15		216.15		216.15	
	next add per inch price of primary vertical stroke (cost of plate)	N/A		3.80		3.80		3.80	
	next add per inch price of secondary vertical stroke (cost of plate)	N/A		–		1.95		1.95	
	next add per inch price of secondary vertical stroke (cost of shaft)	N/A		–		Table 2		Table 2	
	next add per inch price of secondary horizontal stroke (cost of shaft)	N/A		Table 3		–		Table 3	

Step 3 cont'd – Tandem Adj. Stop & Hyd. Shock Options See “EZP” step #3 prices page 90

Table 2 – 1/2" Dia. guide shaft material (Price includes material for 1 pair of shafts)		
Standard	Case hardened guide shafts	2.60
–Z	Stainless steel	7.40

Table 3 – 3/4" Dia. guide shaft material (Price includes material for 1 pair of shafts)		
Standard	Case hardened guide shafts	4.10
–Y	Hollow guide shafts (possible on horizontal unit of EZP7550 only)	13.15
–Z	Stainless steel	10.45

"TS" Series Linear Slides

Step 1 – "TS" Series Basic Slide Model		TS112	TS150	TS200	TS250	TS325	TS400	
Base Price	-MH1, MH2, MH3, MH4 Standard mounting styles	570.50	605.25	669.50	768.00	900.00	1164.95	
	-MV1, MV2, MV3, MV4 Standard mounting styles	570.50	605.25	669.50	768.00	900.00	1164.95	
	-MF1 Flange mount, ports on center	598.85	648.20	731.20	858.50	1051.05	1370.90	
	-MF2 Flange mount, tapped mounting holes - add price per pair	622.75	674.20	760.40	892.95	1093.05	1425.50	
Stroke Adder	Add per inch of stroke	5.30	5.85	6.40	7.60	9.30	10.80	
Special strokes	- add for non-standard strokes	87.65	87.65	87.65	87.65	87.65	87.65	
Mounting Bars	B1 for use with MH or MV – add price per pair	18.75	19.90	22.45	27.20	32.15	39.45	
	B2 for use with prox switch on MH or MV – add price per pair	20.15	21.05	25.40	31.25	37.10	N/A	
Integral Options	-D Dowel hole	33.85	36.20	36.20	36.20	40.85	40.85	
	-V Viton cylinder seals	31.55	33.35	35.05	37.40	43.30	49.10	
	-Z Stainless steel guide shafts Add per inch of stroke	70.65 10.25	77.70 10.25	86.20 10.50	96.15 12.85	113.35 13.45	175.25 18.75	
	-W Rulon® or -X Duralon® shaft bearings (no added cost)	-	-	-	-	-	-	
	See Note 1	-TGSL or -TGRS Tapped guide shafts left or right end	34.80	33.95	37.70	40.35	43.30	50.25
	See Note 1	-TGSB Tapped guide shafts both ends	69.55	71.85	75.40	80.60	86.45	100.45
		-SPL or -SPR Stop plate left or right end	17.25	18.10	18.75	22.20	26.00	29.20
		-SPB Stop plate both ends	34.50	36.20	37.40	44.40	52.00	58.40
		-CL or -CR (specify length) Cushion left or right end	N/A	N/A	49.40	51.15	53.15	57.00
		-CB (specify length) Cushion both ends	N/A	N/A	98.75	102.25	106.35	113.90
	-MSL or -MSR Metallic rod scrapers left or right end	38.90	42.05	44.40	51.70	60.20	68.35	
	-MSB Metallic rod scrapers both ends	77.70	84.15	88.80	103.40	120.30	136.75	
	-USL or -USR Urethane rod scrapers left or right end	38.90	42.05	44.40	51.70	60.20	68.35	
	-USB Urethane rod scrapers both ends	77.70	84.15	88.80	103.40	120.30	136.75	

Note 1 – Tapped guide shaft option is NOT available with Option "Z" (Stainless steel guide shafts)

Step 2 – "TS" Series Sensor Options continued – 2 Meter Cordsets for 12mm Proximity Switches

Straight Cordsets	Part No. PCS01-2M for S12 option32.30	Part No. PCS03-2M for S14 option.....32.30	Part No. PCS05-2M for S16, S18 option 32.30
Rt. Angle Cordsets	Part No. PCS02-2M for S12 option32.30	Part No. PCS04-2M for S14 option.....32.30	Part No. PCS06-2M for S16, S18 option 32.30

Step 2 – "TS" Series Sensing Options		TS112	TS150	TS200	TS250	TS325	TS400	
Prox Switch T (Top) or S (Side) location Note: Requires a tooling option with stop bolt (or customer tooling) to drive prox switch actuator.	-S0000 No sensors desired	-	-	-	-	-	-	
	-S01, S03, S05, S07 L left end or R right end Prox switch - prewired	L left end or R right end	199.80	205.65	208.60	212.65	216.15	224.40
		B both left and right ends	399.65	411.30	417.15	425.35	432.35	448.65
	-S02, S04, S06, S08 Quick disconnect prox switch & cordset	L left end or R right end	239.15	245.00	247.90	252.00	255.45	263.70
		B both left and right ends	478.25	489.90	495.75	503.95	511.00	527.30
	-S12, S14, S16, S18 Quick disconn. prox switch, no cordset	L left end or R right end	206.85	212.65	215.60	219.65	223.20	231.35
		B both left and right ends	413.60	425.35	431.15	439.35	446.35	462.70
	-S40, S41, S42 Prox brackets & actuators only	L left end or R Right end	65.45	71.25	74.20	78.30	81.60	89.65
		B both left and right ends	130.90	142.60	148.40	156.55	163.60	179.40
	Clamp-on Style "J" Sensor at Location #1, 2, 3 or 4	-J70 Magnetic band with reed switch – prewired	L left end or R right end	102.20	102.20	102.20	102.20	109.05
B both left and right ends			134.55	134.55	134.55	134.55	148.20	148.20
-J71 Magnetic band with quick disconnect reed switch & cordset		L left end or R right end	132.35	132.35	132.35	132.35	145.40	146.55
		B both left and right ends	194.80	194.80	194.80	194.80	223.35	223.35
-J72, 74 Magnetic band with electronic sensor – prewired		L left end or R right end	108.45	108.45	108.45	108.45	122.35	122.35
	B both left and right ends	147.05	147.05	147.05	147.05	174.90	174.90	
Dovetail Style "E" Sensor at Location #1, 2, 3 or 4	-E70 Magnetic band with reed switch– prewired	L left end or R right end	99.15	99.15	99.15	99.15	99.15	99.15
		B both left and right ends	117.95	117.95	117.95	117.95	117.95	117.95
	-E71 Magnetic band with quick disconnect reed switch & cordset	L left end or R right end	126.95	126.95	126.95	126.95	126.95	126.95
		B both left and right ends	173.60	173.60	173.60	173.60	173.60	173.60
	-E72, 74 Magnetic band with electronic sensor – prewired	L left end or R right end	104.15	104.15	104.15	104.15	104.15	104.15
		B both left and right ends	128.05	128.05	128.05	128.05	128.05	128.05
	-E73, 75 Magnetic band with quick disconn. electronic sensor & cordset	L left end or R right end	131.90	131.90	131.90	131.90	131.90	131.90
		B both left and right ends	183.50	183.50	183.50	183.50	183.50	183.50
	-E76 Magnetic band with reed switch– prewired	L left end or R right end	98.40	98.40	98.40	98.40	98.40	98.40
		B both left and right ends	116.45	116.45	116.45	116.45	116.45	116.45
-E77 Magnetic band with quick disconnect reed switch & cordset	L left end or R right end	126.15	126.15	126.15	126.15	126.15	126.15	
	B both left and right ends	172.05	172.05	172.05	172.05	172.05	172.05	
Magnetic Band Only	-J8000 Magnetic band only	69.80	69.80	69.80	69.80	69.80	69.80	
	-E80 □ 0 Magnetic band & Dovetail Mtg Rail (location 1, 2, 3 or 4 in box)	80.35	80.35	80.35	80.35	80.35	80.35	

“TS” Series Linear Slides

Step 3 – “TS” Series Bolt-on Options		TS112	TS150	TS200	TS250	TS325	TS400
Horizontal Shaft Mounting Block	-H1L or H1R left or right end mtg. block without stop bolt	35.30	35.95	41.20	43.80	50.55	82.70
	-H1B both ends mounting blocks without stop bolts	70.65	71.85	82.35	87.65	101.05	165.30
	‡ -H2L or H2R left or right end mtg. block with stop bolt	38.90	40.00	45.25	47.95	55.80	89.40
	‡ -H2B both ends mtg. blocks with stop bolts	77.70	80.05	90.60	95.80	111.55	178.75
Vertical Shaft Mounting Block	-V1L or V1R left or right end mtg. block without stop bolt	47.95	49.10	59.00	68.35	78.85	124.15
	-V1B both ends mounting blocks without stop bolts	95.80	98.10	118.00	136.75	157.70	248.30
	‡ -V2L or V2R left or right end mtg. block with stop bolt	51.70	53.15	63.10	72.75	83.85	130.55
	‡ -V2B both ends mtg. blocks with stop bolts	103.40	106.35	126.15	145.50	167.65	261.15
Shaft Clamp Block with Stop Bolt	‡ -H3L or H3R left or right end clamp block	32.40	33.85	38.90	41.30	49.10	83.00
	‡ -H3B both ends clamp blocks	64.85	67.75	77.70	82.65	98.10	165.95
Retainer Plate <i>Use w/TGS option</i>	-RPL or RPR left or right end retainer plate	8.75	9.70	10.50	11.40	13.45	18.10
	-RPB both ends retainer plates	17.55	19.25	21.05	22.80	26.85	36.20
Tooling Mounting Plate & Pair of Shaft Mtg. Blocks	-PLAV1, PLSV1 Aluminum or steel toolplate, vertical shafts, no stop bolt add per inch of stroke	113.90 1.45	121.50 1.70	155.10 2.25	177.05 2.95	237.15 4.10	366.90 7.60
	‡ -PLAV2, PLSV2 Aluminum or steel toolplate, vertical shafts, with stop bolt add per inch of stroke	121.50 1.45	129.70 1.70	163.30 2.25	185.75 2.95	247.10 4.10	379.75 7.60
	-PLAH1, PLSH1 Aluminum or steel toolplate, horizontal shafts, no stop bolt add per inch of stroke	88.80 1.45	95.25 1.70	119.45 2.25	127.95 2.95	180.55 4.10	283.90 7.60
	‡ -PLAH2, PLSH2 Aluminum or steel toolplate, horizontal shafts, with stop bolt add per inch of stroke	95.80 1.45	103.40 1.70	127.65 2.25	136.10 2.95	191.05 4.10	297.40 7.60

Note ‡ – These tooling options feature a stopbolt which requires either an "SP" (steel stop plate) or an "S01" thru "S42" prox option for each stopbolt used. A stopbolt cannot be allowed to stop against the slide's aluminum end cap. Stopbolts must stop against a steel plate.

Linear Slides Replacement Parts

“GB” Series Replacement Parts		GB375	GB500	GB750
Standard Seal Kit	Part No.	GB375-SK	GB500-SK	GB750-SK
	Price	4.05	4.25	4.85
Viton Seal Kit	Part No.	GB375-SKV	GB500-SKV	GB750-SKV
	Price	7.45	8.65	11.25

“SE” Series Replacement Parts		SE250	SE375	SE500	SE625	SE750	SE1000	SE1500
Standard Seal Kit	Part No.	900-0016	900-0017	900-0018	900-0019	900-0020	900-0021	900-0141
	Price	7.00	18.75	20.70	20.70	23.40	29.20	38.90
Viton Seal Kit	Part No.	900-0116	900-0117	900-0118	900-0119	900-0120	900-0121	900-0142
	Price	21.05	36.20	40.60	40.60	45.60	52.60	65.75
Linear Ball Bearing Kit	Part No.	901-0022	901-0023	901-0024	901-0025	901-0026	901-0027	901-0086
	Price	158.90	173.50	188.10	203.30	212.05	345.25	684.70
"W" Rulon Bearing Kit	Part No.	901-0058	901-0059	901-0060	901-0061	901-0062	901-0063	901-0087
	Price	158.90	173.50	188.10	203.30	212.05	345.25	684.70
"X" Duralon Bearing Kit	Part No.	901-0079	901-0080	901-0081	901-0082	901-0083	901-0084	901-0085
	Price	158.90	173.50	188.10	203.30	212.05	345.25	684.70

Linear Slides Replacement Parts

"EZ" Series Replacement Parts		EZ250	EZ375	EZ500	EZ625	EZ750	EZ1000	EZ1500
Standard Seal Kit	Part No.	900-0005	900-0006	900-0001	900-0007	900-0002	900-0003	900-0004
	Price	7.00	18.75	20.70	20.70	23.40	29.20	38.90
Viton Seal Kit	Part No.	900-0105	900-0106	900-0101	900-0107	900-0102	900-0103	900-0104
	Price	21.05	36.20	40.60	40.60	45.60	52.60	65.75
Linear Ball Bearing Kit	Part No.	901-0005	901-0006	901-0001	901-0007	901-0002	901-0003	901-0004
	Price	158.90	173.50	188.10	203.30	212.05	345.25	684.70
"W" Rulon Bearing Kit	Part No.	901-0041	901-0042	901-0037	901-0043	901-0038	901-0039	901-0040
	Price	158.90	173.50	188.10	203.30	212.05	345.25	684.70
"X" Duralon Bearing Kit	Part No.	901-0068	901-0069	901-0064	901-0070	901-0065	901-0066	901-0067
	Price	158.90	173.50	188.10	203.30	212.05	345.25	684.70
Tandem Cyl. Slide Std. Seal Kit	Part No.	N/A	900-0012	900-0008	900-0013	900-0009	900-0010	900-0011
	Price	-	39.45	41.45	41.45	46.95	58.40	77.70
Tandem Slide Viton Seal Kit	Part No.	N/A	900-0112	900-0108	900-0113	900-0109	900-0110	900-0111
	Price	-	72.50	81.20	81.20	91.10	105.20	131.45
Tandem Linear Ball Bearing Kit	Part No.	N/A	901-0006	901-0001	901-0007	901-0002	901-0003	901-0004
	Price	-	173.50	188.10	203.30	212.05	345.25	684.70
"EZP" Series Replacement Parts		EZP5025	EZP7550	EZP5025 Tandem Horiz	EZP7550 Tandem Horiz	EZP7550 Tandem Vert	EZP7550 Tandem Both	
Standard Seal Kit	Part No.	900-0014	900-0015	900-0037	900-0038	900-0039	900-0040	
	Price	51.15	44.10	71.25	67.75	64.85	88.55	
Viton Seal Kit	Part No.	900-0114	900-0115	900-0137	900-0138	900-0139	900-0140	
	Price	81.55	86.20	121.50	131.70	126.80	172.30	
Linear Ball Bearing Kit	Part No.	901-0014	901-0015	901-0014	901-0015	901-0015	901-0015	
	Price	359.05	400.20	359.05	400.20	400.20	400.20	
"W" Rulon Bearing Kit	Part No.	901-0050	901-0051	901-0050	901-0051	901-0051	901-0051	
	Price	359.05	400.20	359.05	400.20	400.20	400.20	
"X" Duralon Bearing Kit	Part No.	901-0077	901-0078	901-0077	901-0078	901-0078	901-0078	
	Price	359.05	400.20	359.05	400.20	400.20	400.20	
"TS" Series Replacement Parts		TS112	TS150	TS200	TS250	TS325	TS400	
Standard Seal Kit	Part No.	900-0022	900-0023	900-0024	900-0025	900-0026	900-0027	
	Price	30.40	31.55	32.70	34.15	44.40	53.15	
Standard Seal Kit with "C" (cushion) "L" or "R"	Part No.	N/A	N/A	900-0028	900-0029	900-0030	900-0031	
	Price	-	-	35.05	37.70	48.20	58.40	
Standard Seal Kit with "C" (cushion) "B" both	Part No.	N/A	N/A	900-0032	900-0033	900-0034	900-0035	
	Price	-	-	37.70	41.20	52.00	63.70	
Viton Seal Kit	Part No.	900-0122	900-0123	900-0124	900-0125	900-0126	900-0127	
	Price	60.80	63.10	67.75	70.10	91.10	111.00	
Viton Seal Kit with "C" (cushion) "L" or "R"	Part No.	N/A	N/A	900-0128	900-0129	900-0130	900-0131	
	Price	-	-	70.10	73.60	94.95	116.30	
Viton Seal Kit with "C" (cushion) "B" both	Part No.	N/A	N/A	900-0132	900-0133	900-0134	900-0135	
	Price	-	-	72.50	77.15	98.75	121.50	
Linear Ball Bearing Kit	Part No.	901-0008	901-0009	901-0010	901-0011	901-0012	901-0013	
	Price	170.90	181.70	188.10	203.30	212.05	345.25	
"W" Rulon Bearing Kit	Part No.	901-0044	901-0045	901-0046	901-0047	901-0048	901-0049	
	Price	170.90	181.70	188.10	203.30	212.05	345.25	
"X" Duralon Bearing Kit	Part No.	901-0071	901-0072	901-0073	901-0074	901-0075	901-0076	
	Price	170.90	181.70	188.10	203.30	212.05	345.25	

Fabco-Air Product Catalog Library

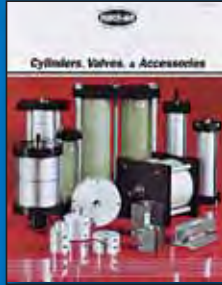

*Cylinders, Valves and Accessories
 Catalog #CV9*



*Pancake® II Air Cylinders
 Catalog Pan2-2*



*Square Pancake® II Air Cylinders
 Catalog # SqPan2*



*ISO 6431 Cylinders
 Catalog # FAQR-09*



Twin Rod, Non-Rotating Air Cylinders - Catalog # FDF-09 and Catalog # FDXS-09



*Multi-Power® Air Presses
 Catalog # FP16*

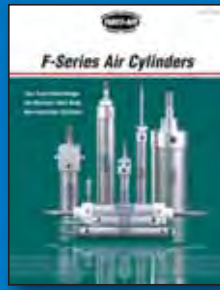

*Stainless Steel Body Air Cylinders
 Catalog # SSB-03*

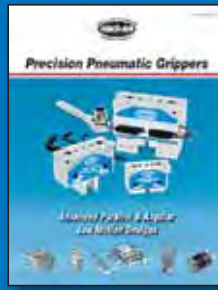

Pneumatic Grippers, Parallel Jaw and Angular Motion - Catalog # GR-8



*Pneumatic Angular Grippers
 Catalog # FKA-09*



*ISO 6432 Cylinders
 Catalog # FAE-09*



NFPA Interchangeable Air Cylinders - Catalog # NF-6



Global Series™ Metric Air Cylinders - Catalog # GC-15



*Swing Clamps
 Bulletin # SC-DB04*



*Manifold Solenoid Valves
 Catalog # FVS-Y-09*



*Air Pilot & Solenoid Valves
 Catalog # FVA.E-09*



*Modular Air Preparation System - FRLs
 Catalog # FRL-06*



*Stopper Cylinders
 Catalog # ST-SC*

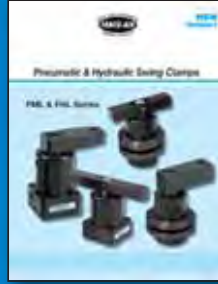

*Swing Clamps, Pneumatic & Hydraulic
 Catalog # FML.H*

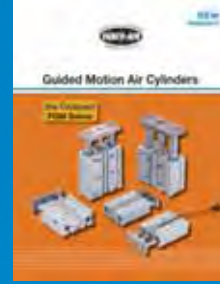

*Guided Motion Air Cylinders
 Catalog # FGM-10*



*Air Slide Tables
 Catalog # FGXS-10*