

Square 1® Air Cylinders

	Page
General Standard Ratings and Sizing Guide.....	2.2
Construction Details	2.3, 2.4
How a Square 1® is built	
Standard Specifications.....	2.5
Model Number Codes.....	2.6
Option List	2.6
How to Order	2.6
Standard Specifications (Dimension Details)	2.7, 2.8
Option Specifications.....	2.9 - 2.14
Description and Dimensions of the Options	
Mounting Kits for SQF and SQFW	
Flange Mounting Kits.....	2.14
Trunnion Mounting Kits.....	2.15
Clevis Bracket Kits.....	2.15
Eye Bracket Kits	2.15
Rod Clevises	2.15
Accessories	
Flow Controls, Port Mounted and Others	Section 12
Position Sensors.....	2.13
Mounting Bolts.....	Section 1.16
Wrench Flat Wrench.....	Section 1.16
Air Spring Return.....	Section 1.15
2 Year Warranty	Inside back cover

Square 1® Cylinders

Available in 3 styles
5 Bore sizes 3/4" thru 2"
Strokes to 6"

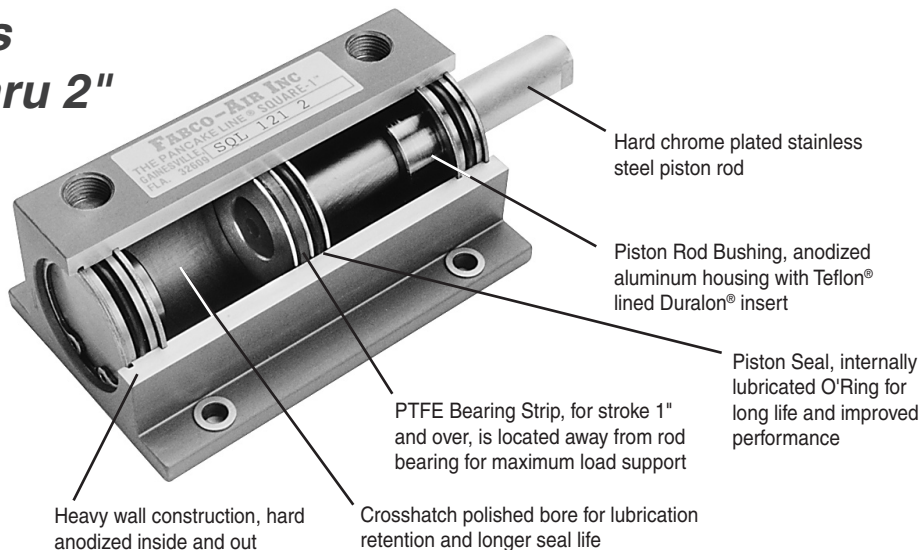

Series SQ, Side Tap Mount

Side view (opposite ports) shows mounting holes and relief for mounting rails.



Series SQF, Face Mount



Series SQL, Side Lug Mount

Duralon® Rod Bearings Excel			
Load Capacity (psi)	Friction Properties		
Machine Design 1972/73			
Bearing Reference Issue		Coefficient	Slip-stick
Porous Bronze..... 4,500	Steel-on-steel50	Yes
Porous iron..... 8,000	Bronze-on-steel35	Yes
Phenolics..... 6,000	Sintered Bronze-on-steel		
Nylon®	with mineral oil13	No
TFE..... 500	Bronze-on-steel		
Reinforced Teflon®..... 2,500	with mineral oil16	No
*TFE fabric..... 60,000	Copper lead alloy-on-steel	.22	Yes
Polycarbonate	Acetal-on-steel20	No
Acetal..... 1,000	Nylon-on-steel32	Yes
Carbon-graphite..... 600	Duralon-on-steel.....	.05 - .16	No

* Shows Duralon bearing classification. Not to be used for design purposes.

Printed with permission by Rexnord Corp.

Ratings – Standard Units all series

- Double acting, single rod
- Duralon® rod bushing
- Female rod end with wrench flats
- Internally lubricated Buna-N O-ring piston and rod seals.
- Ports at position #1
- Media Air, Optional Hydraulic
- Max. operating pressure 150 psi Air or Hydraulic
- Min. operating pressure recommended 10 psi
- Ambient & media temperature range . . . -25° to +250°F
- Prelubrication Magnalube®-G Grease
- Air Line Lubrication Recommended
- Stroke tolerance ± 1/64"

Sizing Guide

	3/4"	7/8"	1-1/8"	1-5/8"	2"
Bore Diameter	3/4"	7/8"	1-1/8"	1-5/8"	2"
Rod Diameter	0.3125	0.3125	0.500	0.625	0.750
Rod Area	0.08	0.08	0.19	0.31	0.44
Push Area (Single Rod)	0.44	0.60	0.99	2.07	3.14
Pull Area	0.36	0.52	0.80	1.76	2.70
SQ & SQF Base Weight, lb.	0.18	–	0.31	0.63	1.05
SQL Base Weight, lb.	–	0.18	0.33	0.70	1.16
Weight Per Inch, lb.	0.13	0.13	0.19	0.32	0.45

2

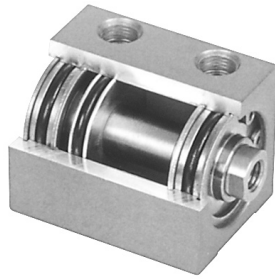

Strokes under 1"

Standard Single Rod Models Shown
 Double Rod: See Option -DR page 2.10
 Nonrotating: See Option -K page 2.12

Strokes 1" and over

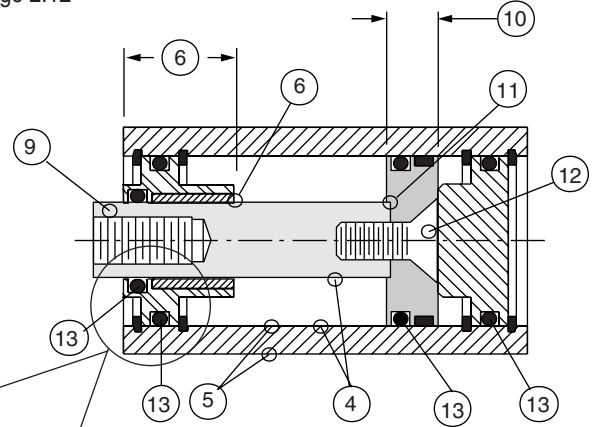
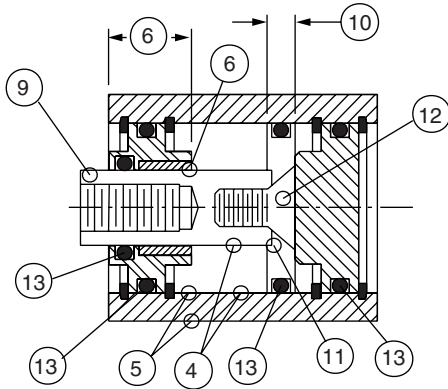

**3/4", 7/8"
 1-1/8", 1-5/8"
 Bores**

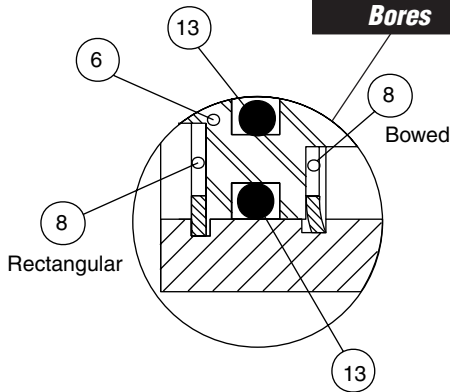

2" Bore



Series SQ

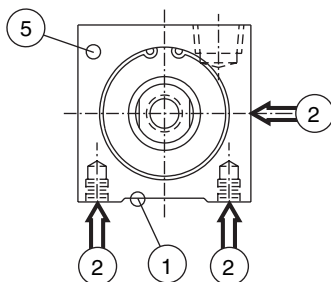

Series SQF

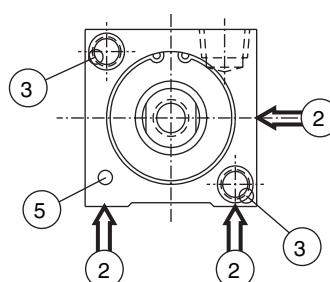

Series SQL

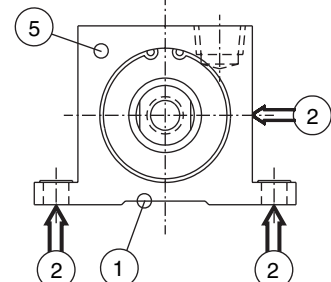

Over 3 decades of experience and close attention to detail at design, production and assembly produce the ultimate Fabco-Air Square 1® Cylinders. They FIT, not only into very tight spaces, but into ANY cylinder application. They WILL fit YOUR application.

1 The square body material is a custom aluminum extrusion with a relief extruded in to provide mounting rails. The SQL series extrusion includes the body side extensions for the Side Lug Mounting. These mounting rails are machined flat before any other machining is done. This step eliminates any twist or curl in the rails, assuring a flat mounting surface.

2 The cylinder body is located on fixture points (↑ ⇐) or the bore during machining operations for other features. This provides an accurate and consistent dimension from the bore centerline to the mounting surface for mounting the cylinder and making attachments to the piston rod.

3 The Face Mount, Series SQF and SQFW, mounting holes are machined in relationship to the centerline of the bore to control the accuracy and consistency for mounting and making attachments to the rod.

4 The cylinder bore is polished to produce a fine cross-hatch finish, which, unlike an ultra smooth finish, provides a reservoir for lubrication. Lubrication, of course, provides lower friction and longer seal life.

5 The cylinder is hard anodized inside and out. This is an electrochemical process which provides a very dense surface of aluminum oxide. This surface has extreme hardness (60 Rc), excellent wear and corrosion resistance, and low coefficient of friction. The hard anodizing actually impregnates the base aluminum rather than just coating the surface like a plating. The hardness and wear resistance exceed that of hard chrome plated steel. The appearance is an attractive, satin gray.

6 Unique construction provides unequalled piston rod support and prohibits rod bushing BLOWOUT! The one-piece Duralon® rod bushing is inserted from the inside and then staked in place. Duralon® is a Teflon® lined, fiberglass structure with load carrying capacity of 60,000 psi. See the chart comparing this to other bearing materials on page 2.2. Duralon® also provides: **consistency**- reliable and predictable performance from bushing to bushing; **corrosion resistance**- nonmetallic materials resist galvanic, chemical, and fretting corrosion; **self lubrication**- Teflon® lining provides low friction and minimizes slipstick, even under no-load conditions; **seizure resistance**- fiberglass backing material will not seize or gall on shaft under extreme wear. Rod bearing length on 1" stroke and over is longer to provide additional load support at the longer extensions. The O'Ring seal is located outboard as far as possible to allow air system lubrication onto most of the bearing surface.

7 The rod bearings and cap end plugs are held in

place by two internal lockrings. In the 2" (321) bore size the inboard lockring and its groove are of standard rectangular cross section. The outboard lockring and its groove are beveled. As the outboard lockring expands in this beveled arrangement, it drives the rod bearing or cap end plug into and tightly against the inboard lockring. This locks the bearing or plug rigidly in place, thus providing precision, non-floating location and rigid support for the piston rod.

8 The rod bearings and cap end plugs are held in place by two internal lockrings. In bore sizes 3/4" (04) thru 1-5/8" (221) all the lockring grooves are of standard rectangular cross section. The internal groove is wider and the lockring is bowed. This bowed lockring drives the rod bearing or cap end plug tightly against the outboard lockring, thus providing precision, non-floating location and rigid support for the piston rod.

9 The piston rod is centerless ground, polished and hard chrome plated (68-72 Rc) stainless steel. Surface finish is 12 RMS or better and carries lubrication like our cylinder bore (see 4). These features, combined with the low friction and high load capacity of the Duralon® bushing provide exceptional cylinder life. Female, fine pitch rod thread and wrench flats are standard.

10 Cylinders with strokes under 1" have a thin piston head with a single O'Ring for space savings. Cylinders with 1" stroke and over have a thicker piston which incorporates a PTFE bearing in addition to the O'Ring seal. This bearing is a close tolerance, rectangular cross section strip of a tough, stable, wear resistant PTFE compound located at the rear of the piston head, the furthest point from the rod bearing. The bearing material and its location provide maximum load support and maintain the long life of the cylinder bore and piston seal.

11 The piston is aluminum for light weight. It has a counterbore which locates the piston rod and provides precise concentricity control for smooth cylinder movement.

12 The piston is attached to the piston rod with a socket flat head screw which is torqued for both proper preload on the screw and secure clamping of the piston. Loctite® on the threads and faces assures sealing and locks the assembly against pounding and vibration.

13 Internally lubricated Buna-N O'Rings (-25° to +250° F) provide low profile, low friction, and long life sealing of the piston and rod. These are compounded to provide extra long wear and low breakaway (starting) pressure, running friction and smoother operation. In tests, cylinders with internally lubricated O'Rings have extended cycle life of 2 to 3 times beyond cylinders with standard Buna-N seals.

Side Tap Mounting: Series SQ

2



Model SQ 121-2

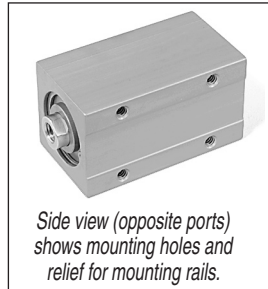

Side view (opposite ports) shows mounting holes and relief for mounting rails.

Bore	Series	Available Stroke Lengths (Inches)										
		1/8	1/4	1/2	3/4	1	1-1/2	2	3	4	5	6
3/4"	SQ04	✓	✓	✓	✓	✓	✓	✓	✓	✓	NA	NA
1-1/8"	SQ121	✓	✓	✓	✓	✓	✓	✓	✓	✓	✓	✓
1-5/8"	SQ221	✓	✓	✓	✓	✓	✓	✓	✓	✓	✓	✓
2"	SQ321	✓	✓	✓	✓	✓	✓	✓	✓	✓	✓	✓

Magnetic piston option does **NOT** affect stroke.

Face Mounting: Series SQF



Model SQF 121-2

Bore	Series	Available Stroke Lengths (Inches)										
		1/8	1/4	1/2	3/4	1	1-1/2	2	3	4	5	6
3/4"	SQF04	✓	✓	✓	✓	✓	✓	✓	✓	✓	NA	NA
1-1/8"	SQF 121	✓	✓	✓	✓	✓	✓	✓	✓	✓	✓	✓
1-5/8"	SQF 221	✓	✓	✓	✓	✓	✓	✓	✓	✓	✓	✓
2"	SQF 321	✓	✓	✓	✓	✓	✓	✓	✓	✓	✓	✓

Magnetic piston option does **NOT** affect stroke.

Side Lug Mounting: Series SQL



Model SQL 121-2

Bore	Series	Available Stroke Lengths (Inches)										
		1/8	1/4	1/2	3/4	1	1-1/2	2	3	4	5	6
7/8"	SQL06	✓	✓	✓	✓	✓	✓	✓	✓	✓	NA	NA
1-1/8"	SQL 121	✓	✓	✓	✓	✓	✓	✓	✓	✓	✓	✓
1-5/8"	SQL 221	✓	✓	✓	✓	✓	✓	✓	✓	✓	✓	✓
2"	SQL 321	✓	✓	✓	✓	✓	✓	✓	✓	✓	✓	✓

Magnetic piston option does **NOT** affect stroke.

All Square 1[®] Mountings

- Double Acting – Single Rod
Choice of "G" or "W" Rod Extension*
- For single acting use air spring as shown on page 1.15
- Double Acting – Double Rod
Choice of combinations of "G" and "W" rod extensions*
- Female Rod End with Wrench Flats
- PTFE Piston Bearing; 1" Stroke and Up
- Internally lubricated Buna-N Seals (-25° to + 250°F)
- Operation to 150 psi
- Rod and Cap End Ports in Position 1A

*For Rod Extension Information See Dimension "G" and "W" on pages 2.6, 2.7 or 2.8.

CAD Drawings on CD-ROM

A complete library of cylinder CAD drawings is available. Contact your local distributor for details, download from our web site <http://www.fabco-air.com> or E-Mail us at fabco@fabco-air.com

Model Number Code



Mounting	Rod Extension	Bore	Standard Strokes Inches	OPTIONS		
				Description	Specify	See Page
SQ Side Tap	Single Rod Models	04 for 3/4" bore	Bores 3/4"	Male Rod Thread		2.9
SQF Face		Blank –for standard extension per dimension "G" on page 2.7	06 for 7/8" bore	7/8"	Single Rod	-MR
SQL Side Lug	W - for Extension to dimension "W" on page 2.7		121 for 1 1/8" bore	1/8	Double Rod, Rod End	-MR
		Double Rod Models See Page 2.10	221 for 1-5/8" bore	1/4	Double Rod, Cap End	-MR1
	Blank –"G" extension both ends		321 for 2" bore	1/2	Double Rod, Both Ends	-MR2
		W –"W" extension both ends		3/4	Viton Seals (-15° to +400°F)	-V
	GW – "G" extension on rod end; "W" extension on cap end			1	Quad Seals	-Q
		WG – "W" extension on rod end; "G" extension on cap end		1-1/2	Metric Rod Thread	-M
				2	Nonrotating	-K
			3	1-1/8", 1-5/8", 2" bores only		
			4	Port Positions	-1B	2.9
			Bores 1-1/8"	External Guide, Nonrotating	-G	2.14
			1-5/8"	Hydraulic, Low Pressure to 150 psi NONSHOCK	-H	2.9
			2"	Double Rod	-DR	2.10
			1/8	Hole Thru Double Rod Shaft		2.10
			1/4	Bore		
			1/2	3/4", 7/8"	1/16"	
			3/4	1-1/8"	1/8"	-DR06
			1	Plus size	5/32"	-DR13
			1-1/2	1-5/8"	1/8"	-DR16
			2	Plus size	1/4"	-DR13
			3	2"	5/32"	-DR25
			4	Plus size	5/16"	-DR16
			5	Stroke Collar	1/8"	C1
			6		1/4"	C2
					3/8"	C3
					1/2"	C4
					5/8"	C5
					3/4"	C6
					7/8"	C7
				Sound Limiters		2.11
				Rod End	-LF	
				Cap End	-LR	
				Both Ends	-LFR	
				Adjustable Retract Stroke	-RS	2.11
				For over 1" adjustment add desired length: e.g. -RS2		
				Magnetic Piston & mounting slot(s) for Piston Position Sensors (Order Sensors separately.)	-E	2.13

How to Order

1. Specify Mounting Series including Rod Extension Information
2. Specify Bore
3. Specify Stroke in Inches and Fractions
4. Specify Options

Examples

SQ 121 - 2

Side Tap Mounting with "G" Rod Extension;
1-1/8" Bore; 2" Stroke

SQW 121 - 2 - MR

Side Tap Mounting with "W" Rod Extension;
1-1/8" Bore; 2" Stroke; Male Rod Thread

SQLW 06 - 3 - C2 - LR

Side Lug Mounting with "W" Rod Extension;
7/8" Bore; 3" Stroke with 1/4" Stroke Collar yielding
2-3/4" Net Stroke; Sound Limiter, Cap End

Mounting Kits for Series SQF

Type	See Page
Flange Mount Kit	2.14
Trunnion Mount Kit	2.15
Clevis Bracket Kit	2.15
Eye Bracket Kit	2.15
Rod Clevis	2.15

SQ Series: Side Tap Mounting – 3/4", 1-1/8", 1-5/8" and 2" Bores

2

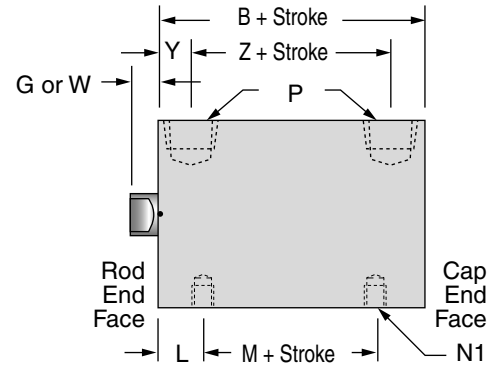
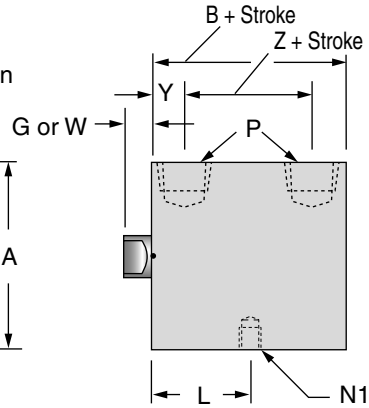
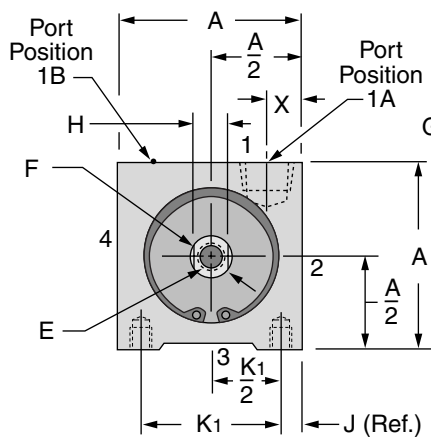

Cylinders with less than 1" stroke have 2 mounting holes

Cylinders with 1" stroke or more have 4 mounting holes

SQL Series: Side Lug Mounting – 7/8", 1-1/8", 1-5/8" and 2" Bores

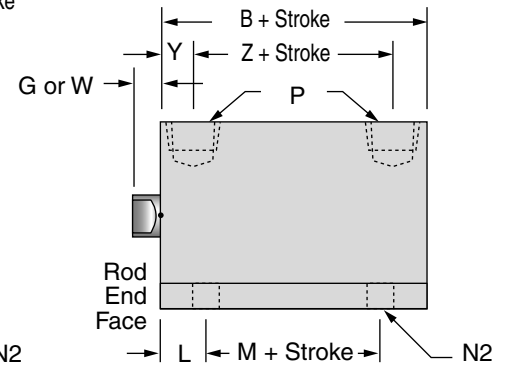
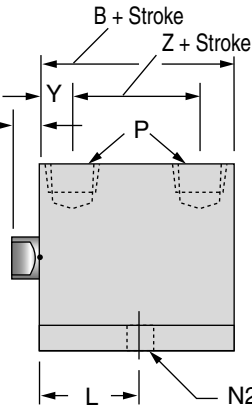
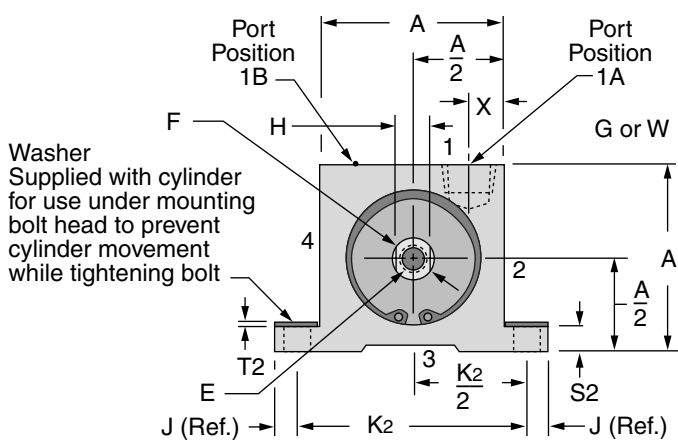

Cylinders with less than 1" stroke have 2 mounting holes

Cylinders with 1" stroke or more have 4 mounting holes

Fixed Dimensions

Bore	A	F Dia.	G	H	J	K1	K2	N1	N2	P	R	S1	S2	T1	T2	U	W	X
3/4"	1.25	.31	.13	1/4	.19	.88	-	10-24x.25	-	10-32	.19	.88	-	1/4-20 x.75dp (Note 2)	-	.75	.38	.31
7/8"	1.25	.31	.13	1/4	.19	-	1.63	-	.21	10-32	-	-	.19	-	.02	-	.38	.31
1-1/8"	1.50	.50	.19	7/16	.19	1.13	1.88	10-24x.25	.21	1/8	.19	1.13	.19	1/4-20 x.75dp (Note 2)	.02	.75	.38	.28
1-5/8"	2.00	.62	.19	1/2	.25	1.50	2.50	1/4-20x.31	.27	1/8	.25	1.50	.25	1/4-20 x.75dp (Note 2)	.03	.75	1.00	.31
2"	2.50	.75	.19	5/8	.25	2.00	3.00	5/16-18x.38	.27	1/8	.25	2.00	.31	5/16-18 x.75dp (Note 3)	.03	.75	1.00	.38

SQF Series: Face Mounting – 3/4", 1-1/8", 1-5/8" and 2" Bores

**Figure 1
Rod End View**

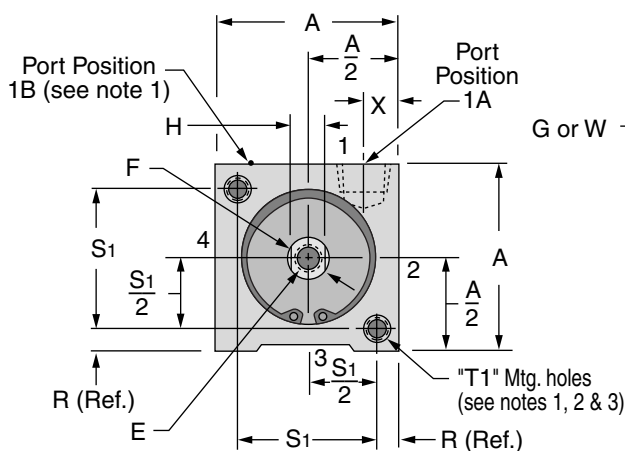

Note 1

"T1" Tapped mounting holes, 2 each end.
When port position "1B" is specified, mounting holes "T1" rotate 90°.

**Figure 2
Side View
Short Strokes**

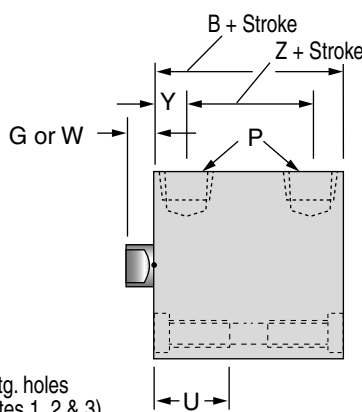

Note 2

3/4", 1-1/8", and 1-5/8" Bores, 1/8" thru 1" Strokes only: .20 Dia. thru, .32 dia. C'Bore x .19 deep for #10 SHCS and 1/4-20 x .75 deep tapped mounting holes, 2 places each end.

Note 3

2" Bore, 1/8" thru 1-1/2" Strokes only: .27 Dia. thru, .38 dia. C'Bore x .26 deep for 1/4" SHCS and 5/16-18 x .75 deep tapped mounting holes, 2 places each end.

**Figure 3
Side View
Long Strokes**

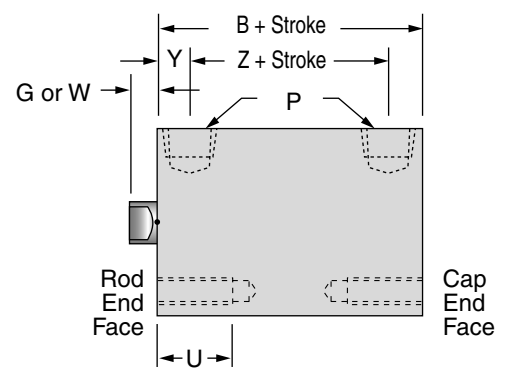

Variable Dimensions

Stroke	3/4" & 7/8" Bores						1-1/8" Bore						1-5/8" Bore						2" Bore					
	B	E	L	M	Y	Z	B	E	L	M	Y	Z	B	E	L	M	Y	Z	B	E	L	M	Y	Z
1/8"	1.03	10-32 x .38	.58	NA	.39	.25	1.28	5/16-24x.44	.70	NA	.44	.41	1.57	3/8-24x.50	.85	NA	.54	.50	1.73	1/2-20x.50	.93	NA	.62	.50
1/4"	1.03	10-32 x .38	.64	NA	.39	.25	1.28	5/16-24x.50	.77	NA	.50	.28	1.57	3/8-24x.63	.91	NA	.54	.50	1.73	1/2-20x.56	.99	NA	.62	.50
1/2"	1.03	10-32 x .38	.76	NA	.39	.25	1.28	5/16-24x.63	.89	NA	.50	.28	1.57	3/8-24x.75	1.04	NA	.54	.50	1.73	1/2-20x.75	1.12	NA	.62	.50
3/4"	1.03	10-32 x .38	.89	NA	.39	.25	1.28	5/16-24x.63	1.01	NA	.50	.28	1.57	3/8-24x.75	1.16	NA	.54	.50	1.73	1/2-20x.88	1.24	NA	.62	.50
1"	1.27	10-32 x .38	.51	.25	.39	.49	1.68	5/16-24x.63	.59	.50	.50	.69	1.94	3/8-24x.75	.66	.63	.54	.88	2.11	1/2-20x.88	.68	.75	.62	.88
1-1/2"	1.27	10-32 x .38	.51	.25	.39	.49	1.68	5/16-24x.63	.59	.50	.50	.69	1.94	3/8-24x.75	.66	.63	.54	.88	2.11	1/2-20x.88	.68	.75	.62	.88
2"	1.27	10-32 x .38	.51	.25	.39	.49	1.68	5/16-24x.63	.59	.50	.50	.69	1.94	3/8-24x.75	.66	.63	.54	.88	2.11	1/2-20x.88	.68	.75	.62	.88
3"	1.27	10-32 x .38	.51	.25	.39	.49	1.68	5/16-24x.63	.59	.50	.50	.69	1.94	3/8-24x.75	.66	.63	.54	.88	2.11	1/2-20x.88	.68	.75	.62	.88
4"	1.27	10-32 x .38	.51	.25	.39	.49	1.68	5/16-24x.63	.59	.50	.50	.69	1.94	3/8-24x.75	.66	.63	.54	.88	2.11	1/2-20x.88	.68	.75	.62	.88
5"	NA	NA	NA	NA	NA	NA	1.68	5/16-24x.63	.59	.50	.50	.69	1.94	3/8-24x.75	.66	.63	.54	.88	2.11	1/2-20x.88	.68	.75	.62	.88
6"	NA	NA	NA	NA	NA	NA	1.68	5/16-24x.63	.59	.50	.50	.69	1.94	3/8-24x.75	.66	.63	.54	.88	2.11	1/2-20x.88	.68	.75	.62	.88

Male Rod Thread

- Single Rod
- Double Rod, Rod End Only
- Double Rod, Cap End Only
- Single Rod, Both Ends

Option

- MR
- MR
- MR1
- MR2

A high strength stud is threaded into the standard female rod end and retained with Loctite®. This method eliminates the small diameter thread relief area normally

required when machining male threads. It provides a much stronger rod end which can be repaired, rather than replacing the complete rod, should the thread be damaged.

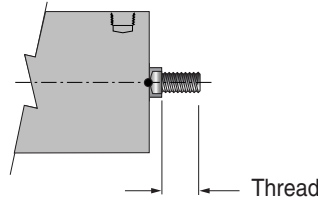
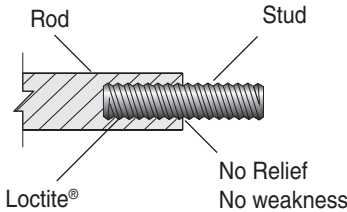

Bore	Thread
3/4"	10-32 x 0.50
7/8"	10-32 x 0.50
1-1/8"	5/16-24 x 0.75
1-5/8"	3/8-24 x 0.88
2"	1/2-20 x 1.00

Viton Seals

Option -V

For elevated temperatures (-15°F to +400°F) or compatibility with exotic media. Consult engineering for compatibility information.

Quad Seals

Option -Q

A **QUAD** seal replaces the standard O'Ring on the piston only. Standard seal material is Buna-N with operating temperatures of -25°F to + 250°F. Consult engineering for other materials.

Metric Rod Thread

Option -M

See page 2.15 for Metric Rod Clevis

Rod threads are configured in common METRIC sizes. To arrive at Female Rod Thread depth in mm, multiply English depth by 25.4. See page 2.15 for Metric Rod Clevis.

Bore	Female Rod Thread	Pitch	Male Rod Thread x Length
3/4	M5	0.8	M5 x 12.7
7/8	M5	0.8	M5 x 12.7
1-1/8	M8	1.25	M8 x 19.0
1-5/8	M10	1.50	M10 x 22.2
2	M12	1.75	M12 x 25.4

Ports Position

Option -1B

Both ports are located at Position 1B (see drawings on page 2.7). This position is achieved by reverse assembly of the cylinder. Therefore, it is a no-charge option. Please note that on Series SQF and SQFW the mounting holes rotate 90°.

Ports can be located in other positions on a special basis. Consult engineering with application requirements for details on other locations.

Hydraulic

Low pressure service to 150psi **NONSHOCK**

Option -H

For Air-over-Oil or Hydraulic systems to 150 psi, **NONSHOCK**. Where space permits, a U-cup rod seal or an additional rod O'Ring is

incorporated in the rod bearing to help prevent fluid carry-over past the rod seal.

Double Rod Option -DR

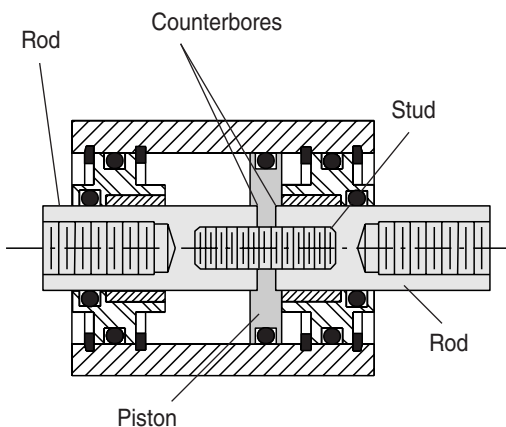

Standard piston rod and rod bushing on both ends of the cylinder. Counterbores on both sides of the piston maintain concentricity of the piston rods to each other as well as to the piston O-ring.

The piston rods are connected by a high strength stud, sandwiching the piston between the rod faces. The assembly is torqued for proper preload of the stud and clamping of the piston head. Loctite® on the threads and faces assures sealing and locks the assembly against pounding and

vibration. This procedure provides a positive and rigid assembly that will not allow the piston rod to float or be pounded loose.

The PTFE piston bearing is not required because the two rod bushings provide excellent piston support.

Use when attachment to both ends of the cylinder is required or to indicate piston position.

The availability of 2 rod extensions offers a number of model combinations as shown in the listings at the left.

- SQ -DR "G" rod ext. both ends.
- SQW -DR "W" rod ext. both ends.
- SQGW . . . -DR "G" rod ext. rod end;
"W" rod ext. cap end.
- SQWG . . . -DR "W" rod ext. rod end;
"G" rod ext. cap end.

- SQF -DR "G" rod ext. both ends.
- SQFW . . . -DR "W" rod ext. both ends.
- SQFGW . . -DR "G" rod ext. rod end;
"W" rod ext. cap end.
- SQFWG . . -DR "W" rod ext. rod end;
"G" rod ext. cap end.

- SQL -DR "G" rod ext. both ends.
- SQLW . . . -DR "W" rod ext. both ends.
- SQLGW . . -DR "G" rod ext. rod end;
"W" rod ext. cap end.
- SQLWG . . -DR "W" rod ext. rod end;
"G" rod ext. cap end.

Single Rod Models

Blank— for standard extension per dimension "G".

W— for extension to dimension "W".

Double Rod Models

Blank— "G" both ends.

W— "W" extension both ends.

GW— "G" extension rod end;
"W" extension cap end.

WG— "W" extension rod end;
"G" extension cap end.

Rod Extension Dimensions					
Bore	3/4"	7/8"	1-1/8"	1-5/8"	2"
G	.13	.13	.19	.19	.19
W	.38	.38	.38	1.00	1.00

Note: When using stroke collars in double rod units, CAP END ROD STICK-OUT increases by amount stroke is shortened.

Hole Thru Double Rod Shaft

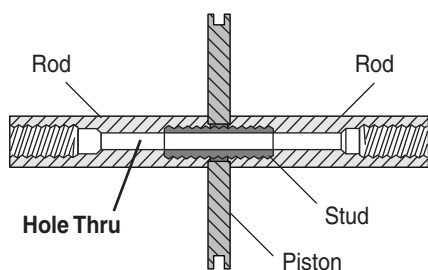

A hole is drilled through the piston rods and the double rod stud. This hole is used for the passage of Vacuum, Air, Gas, Liquid, or any media that is compatible with the stainless steel piston rod and the steel stud. Maximum pressure is

150 psi. The maximum hole size for each bore is shown in the chart below.

The PTFE piston bearing is not required because the two rod bushings provide excellent piston support.

Bore	Standard		Standard Plus	
	Hole Size thru stud	Model No. Suffix (Std)	Hole Size thru stud	Model No. Suffix (Std Plus)
3/4", 7/8"	1/16	-DR06	—	—
1-1/8"	1/8	-DR13	5/32	-DR16
1-5/8"	1/8	-DR13	1/4	-DR25
2"	5/32	-DR16	5/16	-DR31

2

Stroke Collar on piston rod Option

How to Order

- 1) Start with the next longest stroke cylinder.
- 2) Select the amount the stroke is to be shortened.
- 3) Use the corresponding designation immediately after the stroke in the model number.

1/8"	-C1
1/4"	-C2
3/8"	-C3
1/2"	-C4
5/8"	-C5
3/4"	-C6
7/8"	-C7

For those "in-between" strokes, a **STROKE COLLAR** of Delrin[®] is incorporated on the piston rod. The collar fits tightly on the piston rod so that it cannot float as the piston is stroked. Tolerance on the stroke is $\pm 1/64"$. For tighter tolerances on the stroke or final rod position, contact engineering with application details.

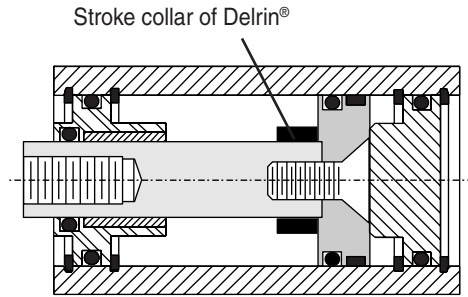

Note: When using stroke collars in double rod units, **CAP END ROD STICK-OUT** increases by amount stroke is shortened.

Adjustable Retract Stroke

Option -RS

Any stroke with up to and including 1" adjustment. Any stroke with over 1" adjustment, specify the adjustment length after the -RS.

Example:

2" Adjustment = -RS2

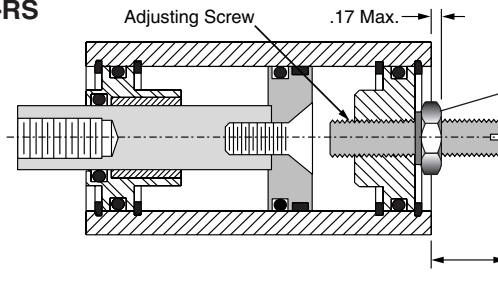

Thread sealing locknut

3/4", 7/8", 1-1/8" Bores = 1/2 Hex
 1-5/8" and 2" Bores = 11/16 Hex

Strokes 1" & Under = .38 Max. + Stroke
 Strokes Over 1" = .38 Max. + Adjustment

An adjusting screw with a thread sealing locknut mounted in the Cap End Plug provides a simple, yet rugged and precision adjustment of the cylinder stroke in the retract direction. Bores 3/4", 7/8", and 1-1/8" have a 5/16"-24 thread giving 0.042" adjustment per revolution. Bores 1-5/8" and 2" have a 1/2"-20 thread giving 0.050" adjustment per revolution.

The **-RS** designation provides full stroke adjustment of any cylinder with 1" stroke or less, and 1" stroke adjustment on all longer strokes. When specifying longer adjustments on longer cylinders, add the desired adjustment to the -RS designation (1/2" increments, please).

Example: -RS2 will provide 2" of adjustment on any cylinder with 2" or more stroke.

Sound Limiters

- Rod End Only
- Cap End Only
- Both Rod & Cap Ends

Option

- LF
- LR
- LFR

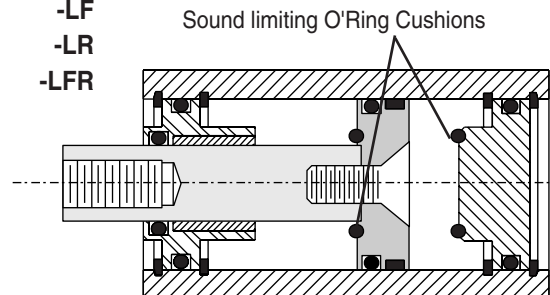

Option -LFR shown

For applications where you need a small amount of cushion at the end of the cylinder stroke to take out the metallic "slap" of piston head on

piston stop. This is accomplished by placing an O'Ring on the rod at the piston, and/or in the cap end plug so that initial contact is with the elastomer and not metal-to-metal.

The Fabco-Air design assures sufficient compression of the seals to allow full stroke.

Because of the temperature limitations of the adhesives involved, sound limiters are available in cylinders with internally lubricated Buna-N O'Rings only.

Nonrotating **Option -K**
1-1/8", 1-5/8", and 2" bores only



Cutaway view of Model SQL 321 - 4 - K

WARNING
 THIS CYLINDER HAS A NONROTATING ROD. TO PREVENT INTERNAL DAMAGE HOLD ROD BY WRENCH FLATS WHEN INSTALLING OR REMOVING ATTACHMENTS.

Wrench flat random rotation

An internal piston guide pin prohibits rod rotation so that objects attached to or moved by the rod will not rotate. Incorporating the guide mechanism inside the cylinder saves you the time, space and cost of mounting external guide pins and bushings in and around your mechanism. The guide pin and bushing are also protected from damage by the environment, the atmosphere, or mechanical abuse. These internal parts are lubricated by the system lubrication.

Available in 1-1/8", 1-5/8", and 2" bores.

May be used in conjunction with all options including -E piston position sensing.

Rotational accuracy is $\pm 1^\circ$. The warning label shown at the left is applied to each cylinder.

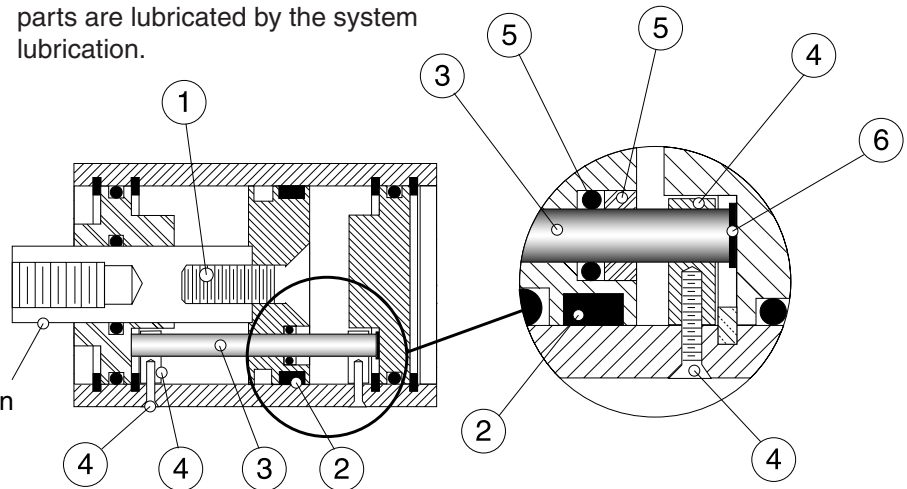

Construction Details

1. The aluminum piston is attached to the piston rod with a socket flat head cap screw which is torqued for proper preload of the screw and clamping of the piston. Loctite® on the threads and faces assures sealing and locks the assembly against pounding and vibration.

2. PTFE bearing is standard in 1" strokes and longer for single rod models.

3. The non-rotating guide pin is ground tool steel for precision and long life. Incorporated inside the cylinder it is protected from environmental dirt and grime and mechanical abuse. It receives lubrication

from the air system lubricator.

4. A precision machined guide pin support block is attached to each end of the cylinder by a flat head screw. These support blocks provide rigid and precise location of the guide pin.

5. The guide pin passes through a polyurethane O-ring seal and an SAE660 bearing bronze bushing installed in the piston head. This combination provides "no-leak" precision guiding and long life.

6. A disk of rubber is included at the end of the guide pin to take up end play and firmly seat the pin in its support blocks.

Magnetic Piston
Includes Dovetail Mounting Slots
Order Sensors Separately

Option -E

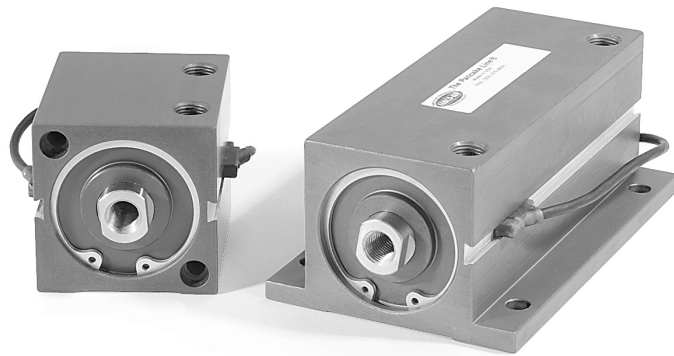

This short stroke **Model SQF** requires two dovetail mounting slots for proper positioning of sensors to detect beginning and end of stroke.

This longer stroke **Model SQL**, side lug mounting style, has room enough to fit multiple sensors in a single slot.

2

- **Dovetail style sensors** are actuated by a magnetic piston.
- Sensor dovetail slides into a mating slot on the cylinder body, is positioned as desired, and locked in place with a set screw.
- Magnetic piston and 1/4" Dovetail mounting slot(s) are specified with Suffix Option "E" in the model number.

- **Order sensors separately.**

SQ Profile

SQF Profile

SQL Profile

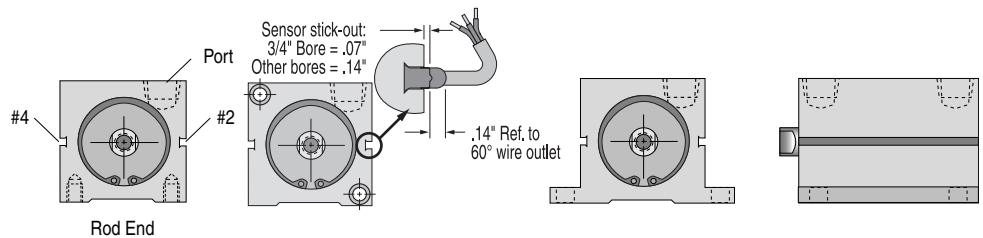

		Standard Stroke & Slot Location Guide											
		SQ (Side Tap)				SQF (Face Mount)				SQL (Side Lug)			
		3/4"	1 1/8"	1 5/8"	2"	3/4"	1 1/8"	1 5/8"	2"	7/8"	1 1/8"	1 5/8"	2"
Stroke	04	121	221	321	04	121	221	321	06	121	221	321	
Sensor Slots at Positions #2 and #4	1/8	✓	✓	✓	✓	✓	✓	✓	✓	✓	✓	✓	✓
	1/4	✓	✓	✓	✓	✓	✓	✓	✓	✓	✓	✓	✓
	1/2	✓	✓	✓	✓	✓	✓	✓	✓	✓	✓	✓	✓
	3/4	✓	✓	✓	✓	✓	✓	✓	✓	✓	✓	✓	✓
Sensor Slot at Position #2 only	1	✓	✓	✓	✓	✓	✓	✓	✓	✓	✓	✓	✓
	1-1/2	✓	✓	✓	✓	✓	✓	✓	✓	✓	✓	✓	✓
	2, 3, 4	✓	✓	✓	✓	✓	✓	✓	✓	✓	✓	✓	✓
	5, 6	NA	✓	✓	✓	NA	✓	✓	✓	NA	✓	✓	✓

Low Profile, Solid State, Magnetic Piston Position Sensors

Temperature Range:
-20° to +80°C (-4° to +176°F)

Female Cordsets for Quick Disconnect	Length	Part No.
	1 Meter	CFC-1M
	2 Meters	CFC-2M
5 Meters	CFC-5M	

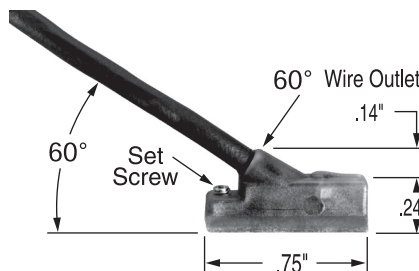

Encased in plastic housing, dovetail style sensors are corrosion resistant. 60° wire outlet allows close mounting. Profile shown here is typical.

Dovetail Style Magnetic Sensors for Square 1[®] Cylinders

Cylinder Model	Sensor Type	Prewired 9 ft. Part No.	Quick Disconnect Part No.*	LED	Electrical Characteristics
All Square 1's	Electronic	949-000-031	949-000-331	Yes	Sourcing PNP 6-24 VDC, 0.20 Amp Max current, 0.5 Voltage Drop
All Square 1's	Electronic	949-000-032	949-000-332	Yes	Sinking NPN 6-24 VDC, 0.20 Amp Max current, 0.5 Voltage Drop

Note*: Quick disconnect styles are supplied with 6 inch pigtail with male connector. Order female cordsets separately.

External Guide, Nonrotating

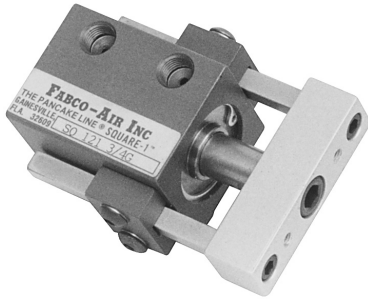

Option -G

Superior nonrotating piston rod feature for applications such as package placement, figure stamping, and any application where anti-rotation and registration are critical as the piston is extended and retracted. A mounting block is bolted to the piston rod. This block has two square pins mounted to it which in turn pass through guide blocks mounted on the sides of the cylinder.

- Square guide pins are hard chrome plated steel for long wear and corrosion resistance.
- Guide blocks are hard anodized aluminum for long wear and corrosion resistance.
- Clearance in guide block mounting holes provide for adjustment and backlash control, compensation for wear, and minimal rotation.
- Extended distance between guides provides superior nonrotation and support.
- Extended piston rod provides clearance between cylinder and guide bar mounting block to eliminate pinch points.

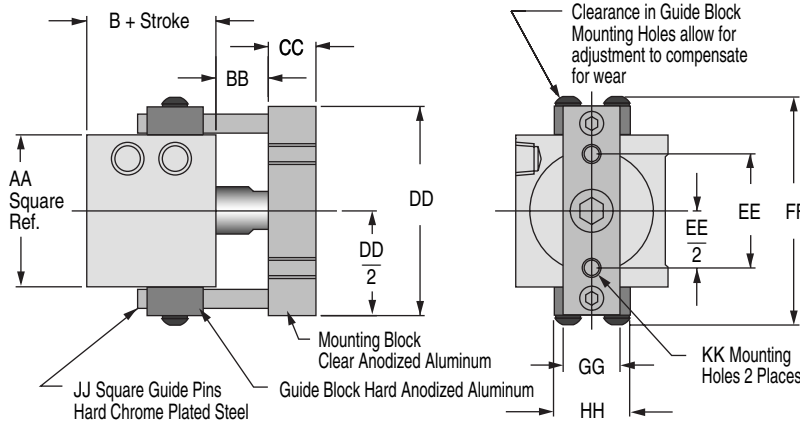

Mounting Series SQ or SQF				
Model	04	121	221	321
Bore	3/4"	1 1/8"	1 5/8"	2"
AA	1.25	1.50	2.00	2.50
BB	.63	.69	.69	.69
CC	.63	.63	.63	.75
DD	1.94	2.26	2.75	3.25
EE	.87	1.06	1.50	1.88
FF	2.19	2.50	3.00	3.50
GG	.63	.63	.75	1.00
HH	1.00	1.00	1.00	1.00
JJ	.19	.25	.25	.25
KK	#6-32	#8-32	1/4-20	5/16-18

Flange Style 7

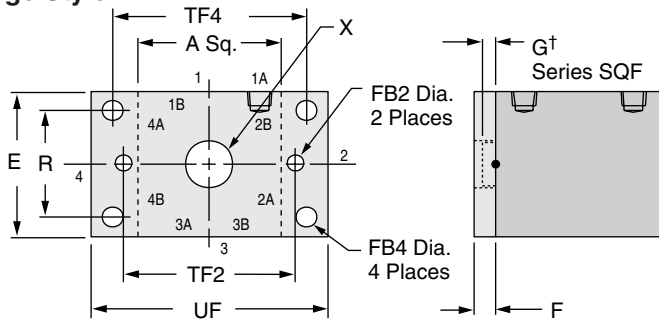

Flange Mounting Kits for Series SQF and SQFW

Flange Style	Bore Size	Fabco Kit No.	Mounting Hole Pattern Interchange Information
7	3/4"	H7-04	4 Hole Pattern C&C: 1-1/8" Bore, Series T, F, & R Mosier: 1-1/8" Bore, Series TAV, 8 & 9 PHD: 1-1/8" Bore, Series AV, RF, & CF 2 Hole Pattern Compact Air: 3/4" Bore, Style S, FF, & RF
7	1-1/8"	H7-121	4 Hole Pattern C&C: 1-1/8" Bore, Series T, F, & R Mosier: 1-1/8" Bore, Series TAV, 8 & 9 PHD: 1-1/8" Bore, Series AV, RF, & CF 2 Hole Pattern Compact Air: 1-1/8" Bore, Style S, FF, & RF
7	1-5/8"	H7-221	4 Hole Pattern NFPA Code MF1 & MF2 for 1-1/2" Bore All brands conforming to this code 2 Hole Pattern Compact Air: 1-5/8" Bore, Style S, FF, & RF
8	2"	H8-321	4 Hole Pattern NFPA Code MF1 & MF2 for 2" Bore All brands conforming to this code
9	2"	H9-321	4 Hole Pattern Compact Air: 2" Bore, Style S, FF, & RF

Kits include Flange and 2 Flange Mounting Screws

Flange Style 8 & 9

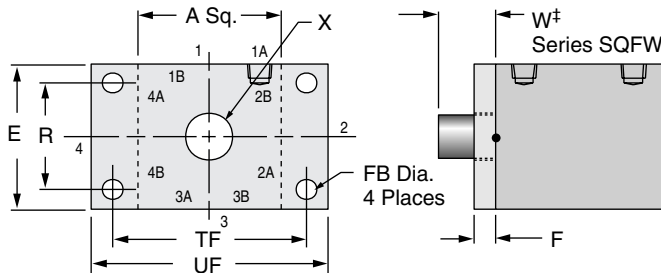

Port Positions

1A Standard all models.
To achieve 2A, 3A or 4A, rotate flange.
For 1B, specify Option -1B
For 2B, 3B, or 4B: Specify Option -1B and rotate flange



SQFW-121-1^{1/2}
with H7-121

Bore	Model	Style	Kit #	A	E	F	FB	FB2	FB4	G†	R	TF	TF2	TF4	UF	W‡	X
3/4"	04	7	H7-04	1.25	1.50	.25	NA	.22	.22	.13	1.00	NA	1.75	2.00	2.50	0.38	.38
1-1/8"	121	7	H7-121	1.50	1.50	.25	NA	.22	.22	.19	1.00	NA	2.00	2.00	2.50	0.38	.56
1-5/8"	221	7	H7-221	2.00	2.00	.38	NA	.22	.31	.19	1.43	NA	2.50	2.75	3.38	1.00	.69
2"	321	8	H8-321	2.50	2.50	.38	.38	NA	NA	.19	1.84	3.38	NA	NA	4.13	1.00	.81
2"	321	9	H9-321	2.50	2.50	.38	.28	NA	NA	.19	2.00	3.00	NA	NA	3.50	1.00	.81

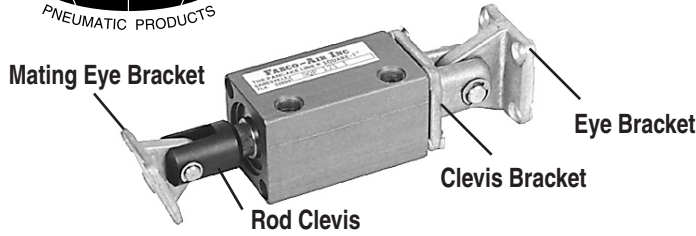

Bore	Stroke	Rod End			Cap End	
		Rod Clevis		Mating Eye Bkt.	Clevis Bracket	Eye Bracket
		English	Metric			
3/4"	All	RC-19	MRC-19	EM-02	PM-04	EM-04
1-1/8"	All	RC-31	MRC-31	EM-04	PM-121	EM-121
1-5/8"	All	RC-38	MRC-38	EM-121	PM-221	EM-221
2"	1/4	RC-54	MRC-54	EM-121	PM-321	EM-321
2"	1/2 Up	RC-56	MRC-56	EM-121	PM-321	EM-321

2

Trunnion Mount Kit for Series SQF

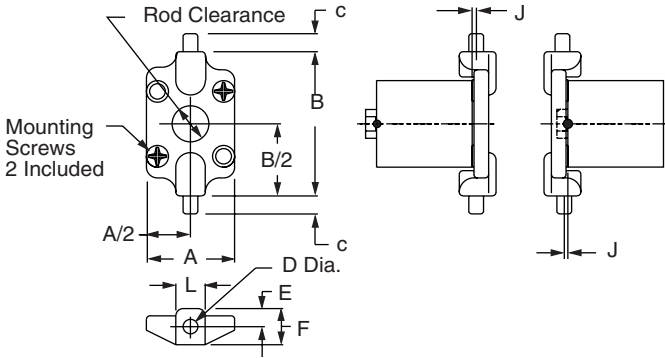

Materials
Bracket: High strength Zinc die casting
Pivot Pins: Precision dowel pins
Clips: 2, Plated steel
Mounting screws: 4, Steel, plated or black oxidized



Bore	Kit No.	A	B	C	D	E	F	J	L
3/4"	TR-04	1.25	2.00	.25	.1253	.25	.50	.07	.38
1-1/8"	TR-121	1.50	2.50	.31	.2503	.31	.63	.06	.50
1-5/8"	TR-221	2.00	3.00	.31	.2503	.44	.81	.06	.63
2"	TR-321	2.50	3.75	.31	.2503	.44	.94	.06	.75

Clevis Bracket Kit for Series SQF

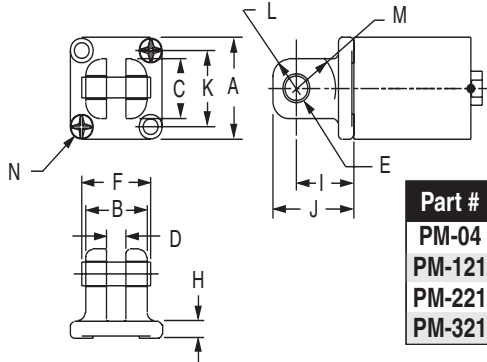

Materials
Bracket: High strength Zinc die casting
Bushings: Oil filled powdered metal
Pin: 416 Stainless Steel
Clips: 2, Plated steel
Screws: 4, Steel, plated or black oxidized

Part #	A	B	C	D	E Pin	E Hole	F	H	I	J	K	L	M	N
PM-04	1.25	0.63	0.63	0.25	.250	.251	0.83	.16	0.56	0.81	0.88	.30	.41	1/4-20x.75
PM-121	1.50	1.00	0.88	0.31	.3125	.3135	1.21	.25	0.94	1.32	1.13	.46	.69	1/4-20x.75
PM-221	2.00	1.25	1.25	0.38	.375	.376	1.48	.31	1.00	1.38	1.50	.52	.69	1/4-20x1.00
PM-321	2.50	1.25	1.25	0.38	.375	.376	1.48	.31	1.00	1.38	2.00	.52	.69	5/16-18x1.00

Eye Bracket Kit for Series SQF

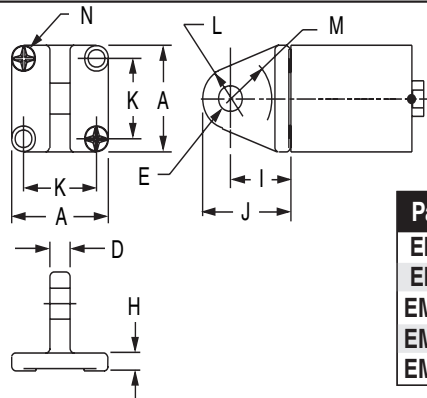

Materials
Bracket: High strength Zinc die casting
Bushings: Oil filled powdered metal
Screws: 4, Steel, plated or black oxidized

**Note: Special 1/4-20 with #12 Phillips Head.*

Part #	A	D	E	H	I	J	K	L	M	N
EM-02	1.25	.18	.1885	.16	0.56	0.87	0.88	.31	.36	1/4-20x.75 FHMS*
EM-04	1.25	.23	.251	.16	0.56	0.87	0.88	.31	.41	1/4-20x.75 FHMS*
EM-121	1.50	.30	.3135	.25	0.94	1.38	1.13	.44	.69	1/4-20x.75 FHMS*
EM-221	2.00	.36	.376	.31	1.13	1.69	1.50	.56	.81	1/4-20x1.00 FHMS*
EM-321	2.50	.36	.376	.31	1.13	1.69	2.00	.56	.81	5/16-18x1.00 FHSCS

Rod Clevises

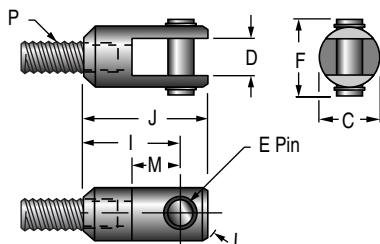

Materials
Clevis and Stud: Steel, black oxidized
Pin: 416 Stainless Steel
Clips: Steel, plated

Part #	C	D	E PIN	F	I	J	L	M	P English	P Metric
RC-19, MRC-19	0.50	.19	.1870	0.70	0.75	1.00	.33	.38	10-32x.25	M5x6.3mm
RC-31, MRC-31	0.75	.25	.2495	0.96	0.88	1.16	.39	.50	5/16-24x.38	M8x9.7mm
RC-38, MRC-38	1.00	.32	.3120	1.21	1.25	1.63	.61	.63	3/8-24x.37	M10x9.4mm
RC-54, MRC-54	1.00	.32	.3120	1.21	1.31	1.69	.61	.63	1/2-20x.39	M12x9.9mm
RC-56, MRC-56	1.00	.32	.3120	1.21	1.31	1.69	.61	.63	1/2-20x.62	M12x15.7mm



Cylinders, Valves, & Accessories

