

# Extruded Body Cylinders, ISO 6431, ISO 15552 compliant Series 62

Double-acting, magnetic, cushioned  
ø 32, 40, 50, 63, 80, 100, (ISO 15552)



- » In compliance with ISO 15552 standards and with the previous DIN/ISO 6431/VDMA 24562 standards
- » Rolled stainless steel rod
- » Clean and light design
- » Adjustable pneumatic cushioning
- » Aluminum Profile
- » Composite piston

Cylinders Series 62 have been designed to comply with the dimensions laid down in the ISO 15552 standards. A permanent magnet is integrated in the piston which enables the detection of the piston position by means of proximity switches (Series CSH) mounted in grooves along one side of the cylinder profile. These grooves can be covered with a slot cover profile Mod. S-CST-500.

These cylinders are equipped with adjustable end-stroke cushioning. They are also equipped with a mechanical cushioning in order to reduce the impact of the piston as it reaches the end of the stroke.

## GENERAL DATA

<b>Type of construction</b>	with tie-rods (inside the profile)
<b>Operation</b>	double-acting
<b>Materials</b>	end-caps = AL, seals = NBR, piston = composite, other parts: see coding
<b>Type of mounting</b>	with tie-rods, front flange, rear flange, feet front and rear trunnion, swivel combination
<b>Stroke min - max</b>	10 – 2500 mm
<b>Operating temperature</b>	0°C – 80°C (with dry air -10°C) (32 - 176°F, with dry air -4°F)
<b>Special designs</b>	see coding example
<b>Operating pressure</b>	1 – 10 bar (14.5 - 145 psi)
<b>Speed</b>	10 – 1000 mm/sec (NO LOAD)
<b>Fluid</b>	filtered air, without lubrication. If lubricated air is used, it is recommended to use oil ISOVG32. Once applied the lubrication should never be interrupted.
<b>Proximity switch to use</b>	CSH

**STANDARD STROKES FOR CYLINDERS SERIES 62**

Special strokes until 2500 mm available on request  
 \* = Double-acting

∅	25	50	75	80	100	125	150	160	200	250	300	320	400	500
32	*	*	*	*	*	*	*	*	*	*	*	*	*	*
40	*	*	*	*	*	*	*	*	*	*	*	*	*	*
50	*	*	*	*	*	*	*	*	*	*	*	*	*	*
63	*	*	*	*	*	*	*	*	*	*	*	*	*	*
80	*	*	*	*	*	*	*	*	*	*	*	*	*	*
100		*	*	*	*	*	*	*	*	*	*	*	*	*

**CODING EXAMPLE**

<b>62</b>	<b>M</b>	<b>2</b>	<b>P</b>	<b>050</b>	<b>A</b>	<b>0200</b>	
-----------	----------	----------	----------	------------	----------	-------------	--

<b>62</b>	SERIES
<b>M</b>	VERSION M= standard, magnetic
<b>2</b>	OPERATION 2 = double-acting, front + rear cushion 3 = double-acting, no cushion 4 = double-acting, rear cushion 5 = double-acting, front cushion 6 = double-acting, through-rod, front + rear cushion
<b>P</b>	MATERIALS P = see general data section on previous page R = stainless steel AISI 420B tie-rods, stainless steel AISI 303 tie-rod nuts C = rolled stainless steel AISI 303 piston rod, stainless steel AISI 304 piston rod nut U = rolled stainless steel AISI 303 piston rod, stainless steel AISI 304 piston rod nut, stainless steel AISI 420B tie-rod, stainless steel AISI 303 tie-rod nuts W = rolled stainless steel AISI 304 piston rod, stainless steel AISI304 piston rod nut, stainless steel AISI 420B tie-rods, stainless steel AISI 303 tie-rod nuts
<b>050</b>	BORE: 032 = 32 mm 040 = 40 mm 050 = 50 mm 063 = 63 mm 080 = 80 mm 100 = 100 mm
<b>A</b>	CONSTRUCTION A = standard lock nut for rod RL = cylinder with rod lock (rod extension required. See table.)
<b>0200</b>	STROKE: 10 – 2500 mm  = standard V = FKM (VITON) piston rod seal ( _ _ _ ) = extended piston rod _ _ _ mm

ISO / VDMA CYLINDERS

## ACCESSORIES FOR CYLINDERS SERIES 62

Piston rod socket joint  
Mod. GY

Piston rod nut Mod. U



Clevis pin Mod. S

Rear trunnion ball-joint  
Mod. RCoupling piece  
Mod. GKF

Swivel ball joint Mod. GA

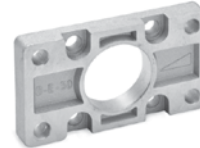
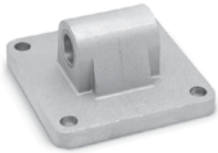
90° male trunnion  
Mod. ZCSwivel Combination  
Mod. IFront and rear flange  
Mod. D-ESelf aligning rod  
Mod. GKRear trunnion male  
Mod. L

Foot mount Mod. B

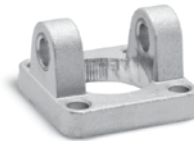
Front female trunnion  
Mod. H and C-HRear female trunnion  
Mod. C and C-H

Rod fork end Mod. G



All accessories are supplied separately, except for piston rod nut Mod. U

Cylinders Series 62



+ = add the stroke

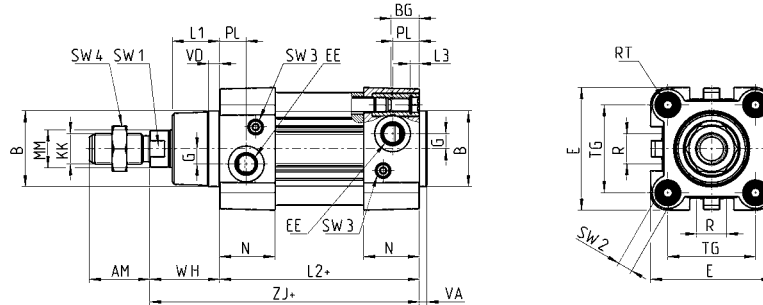

DIMENSIONS (mm)

Ø	AM	B	BG	E	EE	G	KK	L1	L2+	L3	MM	N	PL	R	RT	SW1	SW2	SW3	SW4	TG	VA	VD	WH	ZJ+	front and rear cushion stroke
32	22	30	16	46	G1/8	5	M10x1,25	18	94	5	12	26	14	13	M6	10	6	2	17	32,5	4	5	26	120	17
40	24	35	16	55	G1/4	5	M12x1,25	21	105	5	16	29	15	13,5	M6	13	6	2	19	38	4	5	30	135	20
50	32	40	16	64,5	G1/4	8	M16x1,5	25	106	5	20	29,5	15	16	M8	17	8	3	24	46,5	4	6	37	143	15
63	32	45	16	75	G3/8	8	M16x1,5	26	121	5	20	36,5	21	28	M8	17	8	3	24	56,5	4	6	37	158	17
80	40	45	19	93	G3/8	8	M20x1,5	30	128	0	25	36	21	30	M10	22	10	5	30	72	4	7	46	174	20
100	40	55	19,5	110	G1/2	8	M20x1,5	35	138	0	25	38,5	23	40	M10	22	10	5	30	89	4	7	51	189	21

Cylinders Series 62 - through-rod



+ = add the stroke  
++ = add the stroke two times

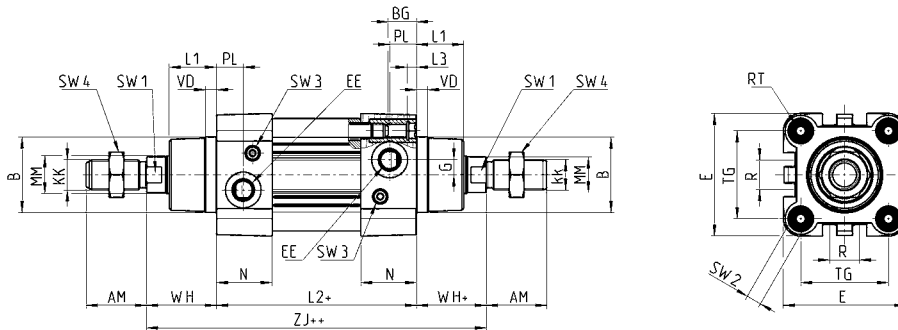

DIMENSIONS (mm)

Ø	AM	B	BG	E	EE	G	KK	L1	L2+	L3	MM	N	PL	R	RT	SW1	SW2	SW3	SW4	TG	VD	WH	ZM+	front and rear cushion stroke
32	22	30	16	46	G1/8	5	M10x1,25	18	94	5	12	26	14	13	M6	10	6	2	17	32,5	5	26	146	17
40	24	35	16	55	G1/4	5	M12x1,25	21	105	5	16	29	15	13,5	M6	13	6	2	19	38	5	30	165	20
50	32	40	16	64,5	G1/4	8	M16x1,5	25	106	5	20	29,5	15	16	M8	17	8	3	24	46,5	6	37	180	15
63	32	45	16	75	G3/8	8	M16x1,5	26	121	5	20	36,5	21	28	M8	17	8	3	24	56,5	6	37	195	17
80	40	45	19	93	G3/8	8	M20x1,5	30	128	0	25	36	21	30	M10	22	10	5	30	72	7	46	220	20
100	40	55	19,5	110	G1/2	8	M20x1,5	35	138	0	25	38,5	23	40	M10	22	10	5	30	89	7	51	240	21

The company reserves the right to vary models and dimensions without notice. These products are designed for industrial applications and are not suitable for sale to the general public.

Cylinders Series 62 with rod lock

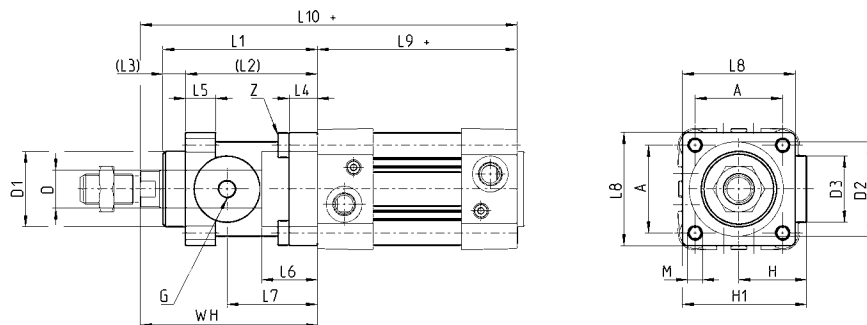

∅	Rod extension [X] (mm)	Holding force [static load] (N)
20	+50	300
25	+48	400
32	+40	650
40	+43	1100
50	+57	1600
63	+57	2500
80	+80	4000
100	+80	6300
125	+125	8800

+ = add the stroke

DIMENSIONS (mm)																					
∅	∅D	∅D1	∅D2	∅D3	A	G	H	H1	L1	L2	L3	L4	L5	L6	L7	L8	L9+	L10+	M	WH	Z
32	12	30,5	35	25	32,5	M5	25,5	46,5	58	48	10	8	13	20,5	34	45	94	160	M6	66	M6x20
40	16	35	40	28	38	G1/8	30	53	65	55	10	8	13	22,5	38	50	105	178	M6	73	M6x20
50	20	40	50	35	46,5	G1/8	36	64	82	70	12	15	16	29,5	48	60	106	200	M8	94	M6x20
63	20	45	60	38	56,5	G1/8	40	75	82	70	12	15	16	29,5	49,5	70	121	215	M8	94	M8x30
80	25	45	80	48	72	G1/8	50	95	110	90	20	18	20	35	61	90	128	254	M10	126	M10x35
100	25	55	100	58	89	G1/8	58	110,5	115	100	15	18	20	39	69	105	138	269	M10	131	M10x35

Foot mount Mod. B

Material: zinc-plated steel



Supplied with:  
2x feet  
4x screws

+ = add the stroke

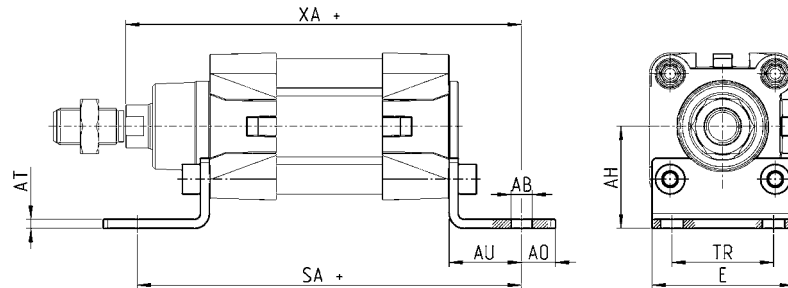

Mod.	∅	AT	SA+	XA+	TR	E	AB	AH	AO	AU
B-41-32	32	4	142	144	32	45	7	32	11	24
B-41-40	40	4	161	163	36	53,5	10	36	15	28
B-41-50	50	4	170	175	45	62,5	10	45	15	32
B-41-63	63	5	185	190	50	73	10	50	15	32
B-41-80	80	6	210	216	63	92	12	63	20	41
B-41-100	100	6	220	230	75	108,5	14,5	71	25	41

Front and rear flange Mod. D-E

Material: aluminium

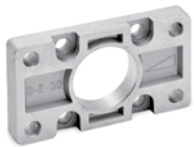

Supplied with:  
1x flange  
4x screws

+ = add the stroke

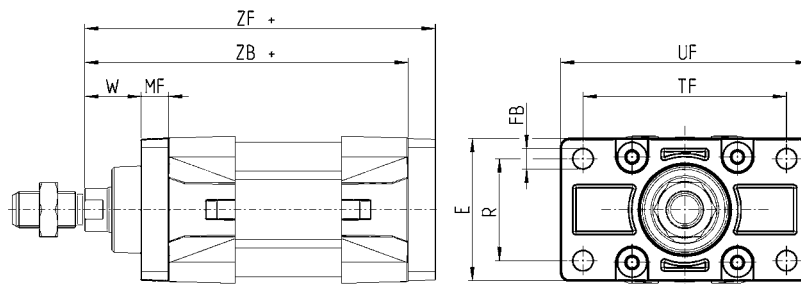

Mod.	∅	W	MF	ZB+	TF	R	UF	E	FB	ZF+	torque force
D-E-41-32	32	16	10	120	64	32	86	45	7	130	6 Nm
D-E-41-40	40	20	10	135	72	36	88	52	9	145	6 Nm
D-E-41-50	50	25	12	143	90	45	110	63	9	155	13 Nm
D-E-41-63	63	25	12	158	100	50	116	73	9	170	13 Nm
D-E-41-80	80	30	16	174	126	63	148	95	12	190	19 Nm
D-E-41-100	100	35	16	189	150	75	176	115	14	205	22 Nm

The company reserves the right to vary models and dimensions without notice. These products are designed for industrial applications and are not suitable for sale to the general public.

Rear female trunnion Mod. C and C-H

Material: Aluminium

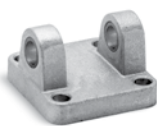

Supplied with:  
1x female trunnion  
4x screws

+ = add the stroke

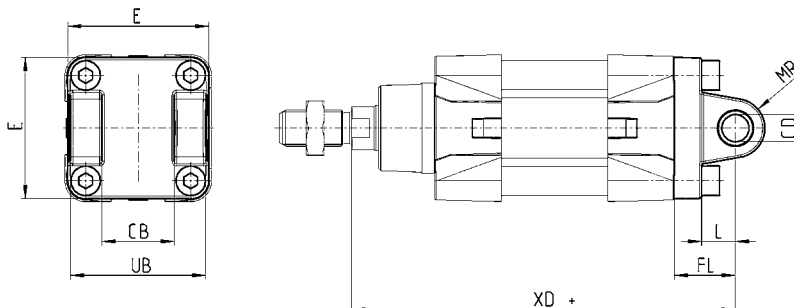

Mod.	∅	CD	L	FL	XD+	MR	E	CB	UB	torque force
C-41-32	32	10	12	22	142	10	45	26	45	6 Nm
C-41-40	40	12	15	25	160	13	52	28	52	6 Nm
C-41-50	50	12	15	27	170	13	63	32	60	13 Nm
C-H-41-63	63	16	20	32	190	15	73	40	70	13 Nm
C-H-41-80	80	16	24	36	210	15	95	50	90	19 Nm
C-H-41-100	100	20	29	41	230	18	115	60	110	26 Nm

Front female trunnion Mod. H and C-H

Material: Aluminium

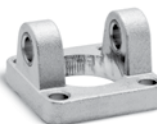

Supplied with:  
1x female trunnion  
4x screws

+ = add the stroke

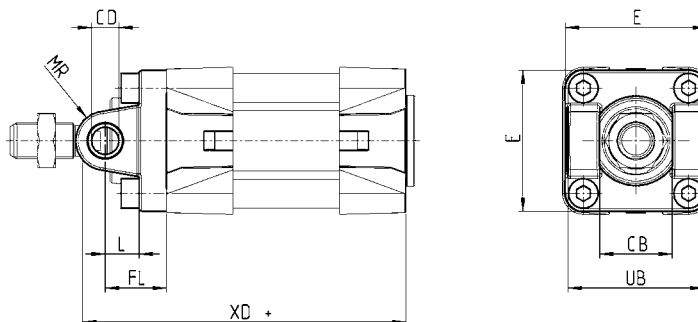

Mod.	∅	CB	UB	E	XD	FL	L	CD	MR
H-41-32	32	26	45	45	120	22	12	10	10
H-41-40	40	28	52	52	135	25	15	12	13
H-41-50	50	32	60	63	143	27	15	12	13
H-60-63	63	40	70	73	158	32	20	16	15
C-H-41-80	80	50	90	95	174	36	24	16	15
C-H-41-100	100	60	110	115	189	41	29	20	18

Rear trunnion, male Mod. L

Material: aluminium



Supplied with:  
1x male trunnion  
4x screws

+ = add the stroke

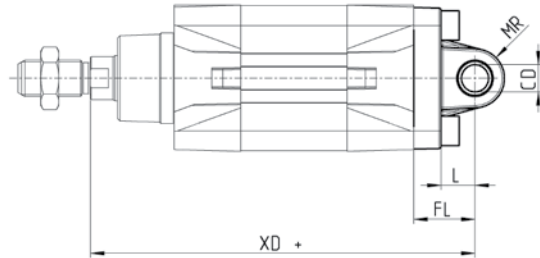
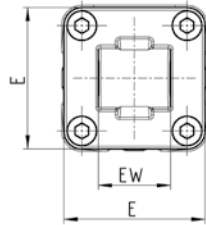

Mod.	∅	CD	L	FL	XD+	MR	E	EW	torque force
L-41-32	32	10	12	22	142	9	45	26	6 Nm
L-41-40	40	12	15	25	160	13	52	28	6 Nm
L-41-50	50	12	15	27	170	13	63	32	13 Nm
L-41-63	63	16	20	32	190	15	73	40	13 Nm
L-41-80	80	16	24	36	210	15	95	50	19 Nm
L-41-100	100	20	29	41	230	18	115	60	22 Nm

Trunnion ball-joint Mod. R\*

Material: Aluminium

\* not according to standard

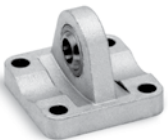

Supplied with:  
1x trunnion ball-joint  
4x screws

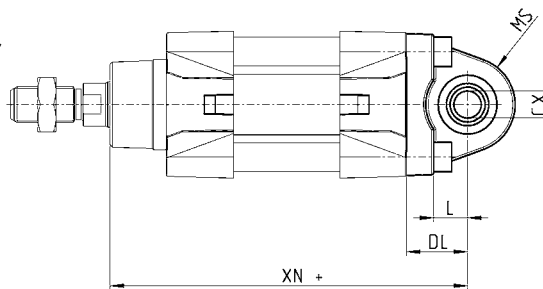
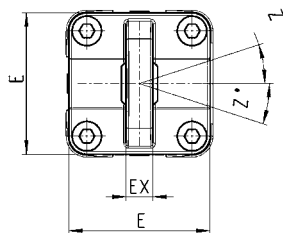

Mod.	∅	CX	L	DL	XN+	MS	E	EX	EP	Z	Torque force
R-41-32	32	10	12	22	142	16	45	14	10,5	4	6 Nm
R-41-40	40	12	15	25	160	20	52	16	12	4	6 Nm
R-41-50	50	12	15	27	170	20	63	16	12	4	13 Nm
R-41-63	63	16	20	32	190	24	73	21	15	4	13 Nm
R-41-80	80	16	24	36	210	24	95	21	15	4	19 Nm
R-41-100	100	20	29	41	230	30	115	25	18	4	22 Nm

The company reserves the right to vary models and dimensions without notice.  
These products are designed for industrial applications and are not suitable for sale to the general public.

Accessory combination Mod. I (combination of models C + L + S)

Material: Aluminium



+ = add the stroke

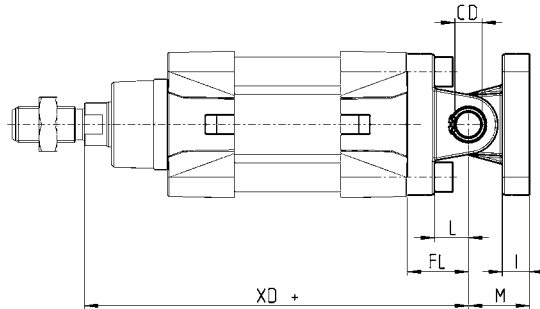
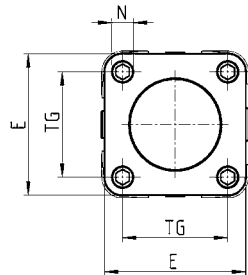

Mod.	∅	∅CD	L	FL	XD+	MR	E	CB	UB	torque force
I-41-32	32	10	12	22	142	10	45	26	45	6 Nm
I-41-40	40	12	15	25	160	10	52	28	52	6 Nm
I-41-50	50	12	15	27	170	13	63	32	60	13 Nm
I-41-63	63	16	20	32	190	15	73	40	70	13 Nm
I-41-80	80	16	24	36	210	15	95	50	90	19 Nm
I-41-100	100	20	29	41	230	18	115	60	110	26 Nm

90° male trunnion Mod. ZC

CETOP RP 107P  
Material: Aluminium



Supplied with:  
1x male support

+ = add the stroke

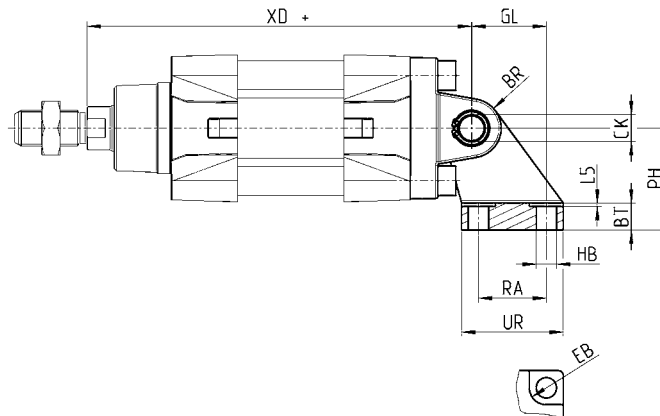
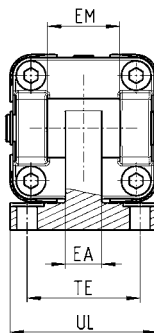

Mod.	∅	EB	CK	HB	XD+	TE	UL	EA	GL	L5	RA	EM	UR	PH	BT	BR
ZC-32	32	11	10	6,6	142	38	51	10	21	1,6	18	26	31	32	8	10
ZC-40	40	11	12	6,6	160	41	54	15	24	1,6	22	28	35	36	10	11
ZC-50	50	15	12	9	170	50	65	16	33	1,6	30	32	45	45	12	13
ZC-63	63	15	16	9	190	52	67	16	37	1,6	35	40	50	50	14	15
ZC-80	80	18	16	11	210	66	86	20	47	2,5	40	50	60	63	14	15
ZC-100	100	18	20	11	230	76	96	20	55	3,2	50	60	70	71	17	19

### Accessory to mount valves on the cylinder

The mounting sub-base Mod. PCV enables the valve or solenoid valve to be mounted directly on the cylinder by means of set screws that assemble through the PCV plate and into the slots of the profile extrusion.



Make sure that the total length of the selected valve (WW) is smaller than the dimension JJ of the selected cylinder.  
For more information see [www.camozzi.com/products/area/downloads](http://www.camozzi.com/products/area/downloads).

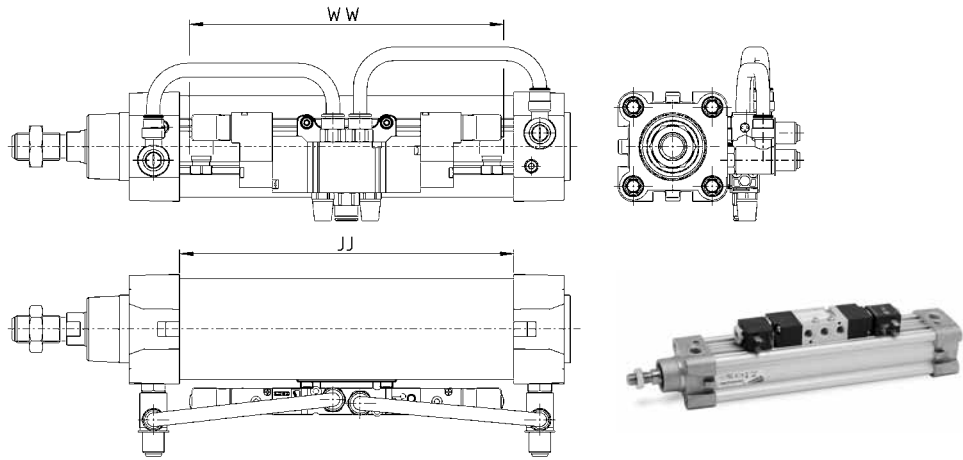

Mod.	
PCV-62-K3	to connect valves - solenoid valves Series 3
PCV-62-K4	to connect valves - solenoid valves Series 4 port G1/4
PCV-62-KEN	to connect valves - solenoid valves Series EN
PCV-62-K8	to connect valves - solenoid valves Series 4 port G1/8 and Series 3 port G1/4

### Clevis pin Mod. S



Supplied with:  
1x clevis pin (stainless steel 303)  
2x C-clips (plain carbon steel)

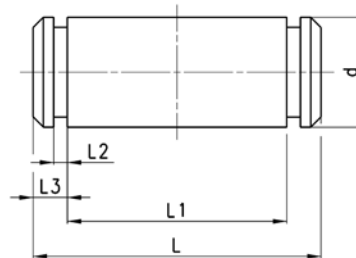

Mod.	Ø	d	L	L1	L2	L3
S-32	32	10	52	46	1,1	3
S-40	40	12	59	53	1,1	3
S-50	50	12	67	61	1,1	3
S-63	63	16	77	71	1,1	3
S-80	80	16	97	91	1,1	3
S-100	100	20	121	111	1,3	5

Swivel ball joint Mod. GA

Material: zinc-plated steel  
ISO 8139

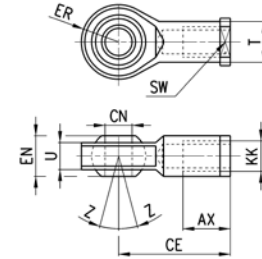

Mod.	ØCN	U	EN	ER	AX	CE	KK	T	Z	SW
GA-32	10	10,5	14	14	20	43	M10X1,25	15	6,5	17
GA-40	12	12	16	16	22	50	M12X1,25	17,5	6,5	19
GA-50-63	16	15	21	21	28	64	M16X1,5	22	7,5	22
GA-80-100	20	18	25	25	33	77	M20x1,5	27,5	7	30

Piston rod socket joint Mod. GY

Material: Zinc-Aluminum alloy and zinc-plated steel

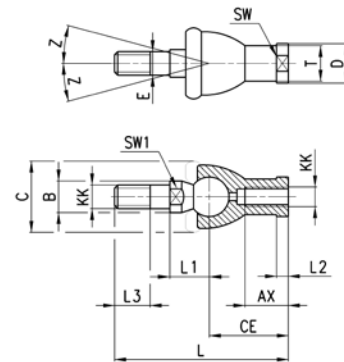

Mod.	Ø	KK	L	CE	L2	AX	SW	SW1	L1	L3	ØT	ØD	E	ØB	ØC	Z
GY-32	32	M10X1,25	74	35	6,5	18	17	11	19,5	15	15	19	10	14	28	15
GY-40	40	M12X1,25	84	40	6,5	20	19	17	21	17	17,5	22	12	19	32	15
GY-50-63	50-63	M16X1,5	112	50	8	27	22	23	27,5	23	22	27	16	22	40	11
GY-80-100	80-100	M20x1,5	133	63	10	38	30	25	31,5	25	27,5	34	20	27	45	7,5

Rod fork end Mod. G

Material: zinc-plated steel  
ISO 8140

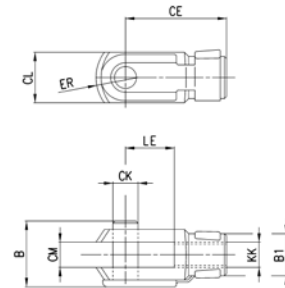

Mod.	Ø	ØCK	LE	CM	CL	ER	CE	KK	B	B1
G-25-32	32	10	20	10	20	12	40	M10 X 1,25	26	18
G-40	40	12	24	12	24	14	48	M12 X 1,25	32	20
G-50-63	50-63	16	32	16	32	19	64	M16 X 1,5	40	26
G-80-100	80-100	20	40	20	40	25	80	M20 X 1,5	48	34

Piston rod nut Mod. U

Material: zinc-plated steel  
UNI EN ISO 4035

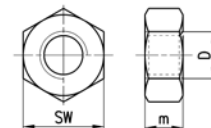

Mod.	D	m	SW
U-25-32	M10X1,25	6	17
U-40	M12X1,25	7	19
U-50-63	M16X1,5	8	24
U-80-100	M20x1,5	9	30

Self aligning rod Mod. GK

Material: zinc-plated steel

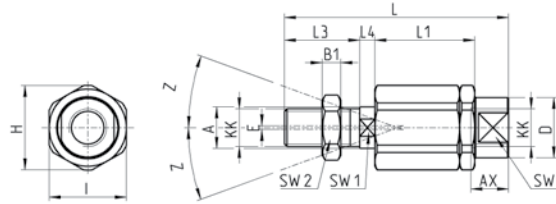

Mod.	Ø	KK	L	L1	L3	L4	ØA	ØD	H	I	SW	SW1	SW2	B1	AX	Z	E
GK-25-32	25-32	M10x1,25	71,5	35	20	7,5	14	22	32	30	19	12	17	5	22	4	2
GK-40	40	M12x1,25	75,5	35	24	7,5	14	22	32	30	19	12	19	6	22	4	2
GK-50-63	50-63	M16x1,5	104	53	32	10	22	32	45	41	27	20	24	8	30	3	2
GK-80-100	80-100	M20x1,5	119	53	40	10	22	32	45	41	27	20	30	10	37	3	2

Coupling piece Mod. GKF

Material: zinc-plated steel

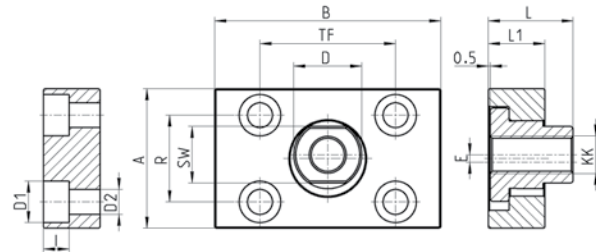
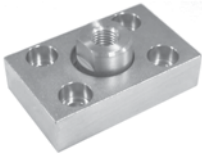

Mod.	Ø	KK	A	B	R	TF	L	L1	I	Ø D	Ø D1	Ø D2	SW	E
GKF-25-32	32	M10x1,25	37	60	23	36	22,5	15	6,8	18	11	6,6	15	2
GKF-40	40	M12x1,25	56	60	38	42	22,5	15	9	20	15	9	15	2,5
GKF-50-63	50-63	M16x1,5	80	80	58	58	26,5	15	10,5	25	18	11	22	2,5
GKF-80-100	80-100	M20x1,5	90	90	65	65	32,5	20	13	30,5	20	14	27	2,5