



# LM Actuator

Equipped with Caged Ball  
LM Guides and QZ Lubricator  
for Ball Screw

# GL-N



**US Only  
Quick Delivery**

*\* Standard options only. Please refer to list in page 6.*

For details, visit THK at [www.thk.com](http://www.thk.com)

\*Product information is updated regularly on the THK website.

**THK CO., LTD.**  
TOKYO, JAPAN

CATALOG No. 177-4E-US

# Structures of LM Actuator GL-N Model

## Ball Screw

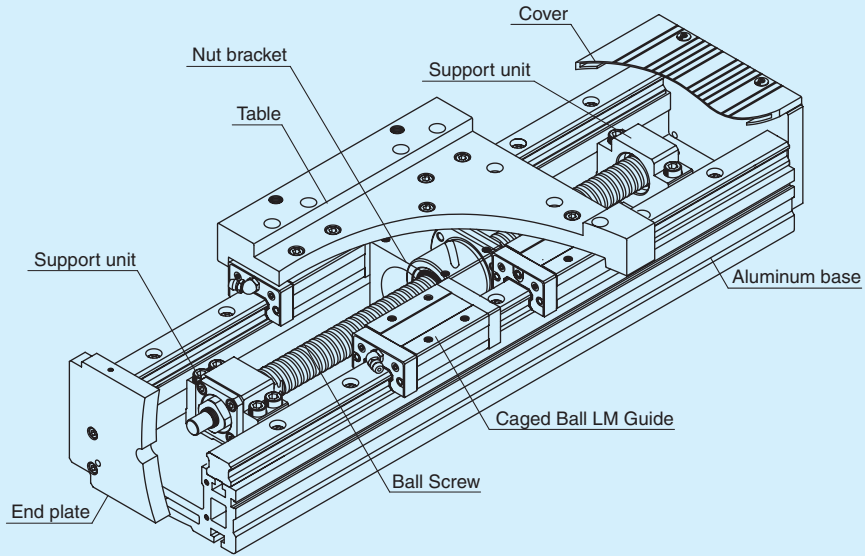

Figure 1 Ball Screw Type Structure

## Timing Belt

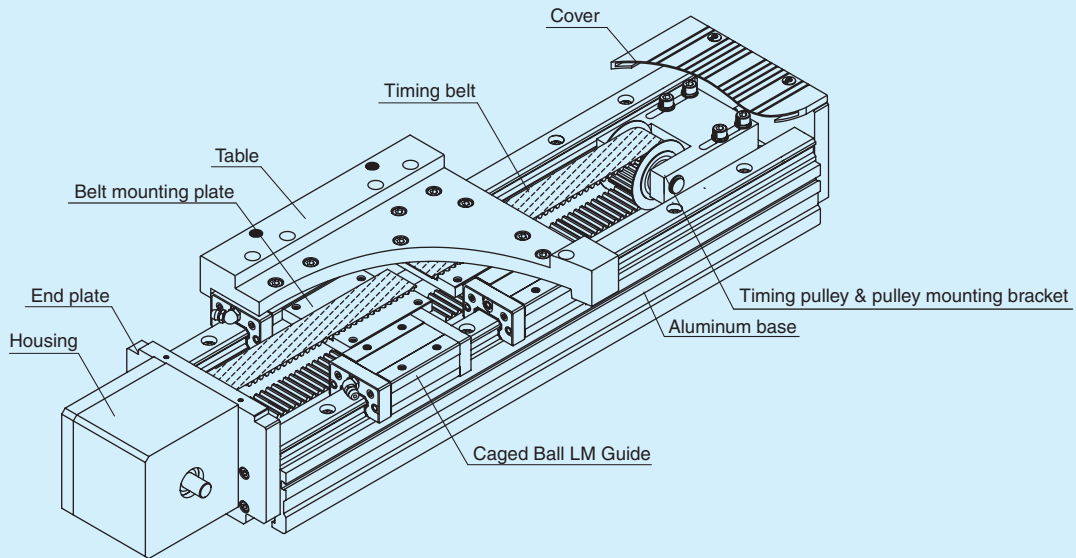

Figure 2 Timing Belt Type Structure

## Features of LM Actuator GL-N Model

Lightweight, high rigidity aluminum base with Caged Ball LM Guides has been utilized for the guide portion. A screw or belt options are available for the drive system.

In addition, Caged Ball LM Guides and QZ Lubricator for the Ball Screw has been utilized to provide a long-term maintenance free actuator.

### Utilizing Caged Ball LM Guide (SSR, SHS)

SSR model: Due to its 90-degree ball contact structure, is best suited to horizontal applications with relatively low moment loads.

SHS model: It can handle loads from all directions (radial, reverse radial, and horizontal) with its 4-way equal load rating capability.

### Drive System

#### [Ball Screw Type]

Variety of screw leads can be selected.

Table 1 Ball Screw Leads by Model Numbers (Rolled ball screw)

Model number	Ball Screw lead (mm)
GL15N	5, 10, 16, 20, 30
GL20N	5, 10, 20, 40

Note: For wrap-around motor types, three motor directions (left, right and bottom) can be selected. (See page 4 for details.)

#### [Timing Belt Type]

Highly rigid timing belt ensures that high speed processes are possible for longer stroke applications than the Ball Screw driven type.

Table 2 Pitch Diameter of the Timing Pulley

Model number	Pitch diameter (mm)	Slider move distance per pulley rotation (mm)
GL15N	35.01	$35.01 \times \pi \approx 110$
GL20N	38.20	$38.20 \times \pi \approx 120$

Note: Because the timing pulley has a large pitch diameter, the use of a reducer is recommended. For details, see pages 18 and 19.

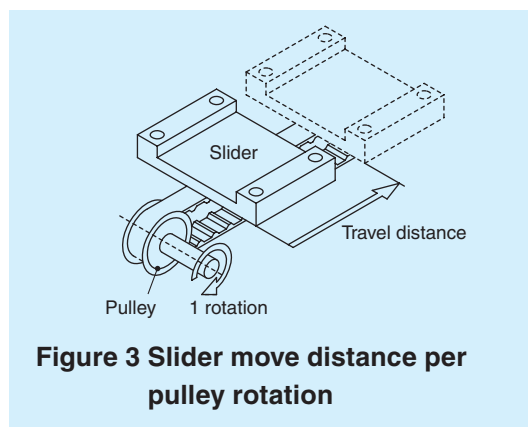

Figure 3 Slider move distance per pulley rotation

### Lightweight and High Rigidity

By using a hollow aluminum extrusion, lightweight and high rigidity is achieved.

Table 3 Geometrical Moment of Inertia and Weight in the Base

Model number	Geometrical Moment of Inertia		Weight (kg/m)
	$I_x$ (mm <sup>4</sup> )	$I_y$ (mm <sup>4</sup> )	
GL15N	$1.61 \times 10^5$	$2.47 \times 10^6$	4.85
GL20N	$3.15 \times 10^5$	$4.28 \times 10^6$	6.47*

\* The weight of the SSR model is 6.69kg/m.

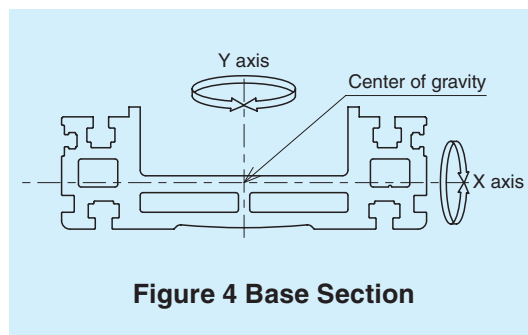

Figure 4 Base Section

## GL-N Model also available with optional QZ Lubricator

A Caged Ball LM Guide and QZ Lubricator for the Ball Screw have been utilized to ensure a long-term maintenance-free actuator.

## Ensuring Adaptability with Most Advanced Motors

A large variety of flanges have been engineered so that a wide selection of motor options are available to be used with the GL-N.

## Multiple Options Available

Multiple options such as covers, bellows, sensors and cable carriers are available.

## Compatible with the Conventional GL Model

Due to the dimensions between the GL models and the GL-N models are same. Replacing with the GL-N is easily possible (GL20N).

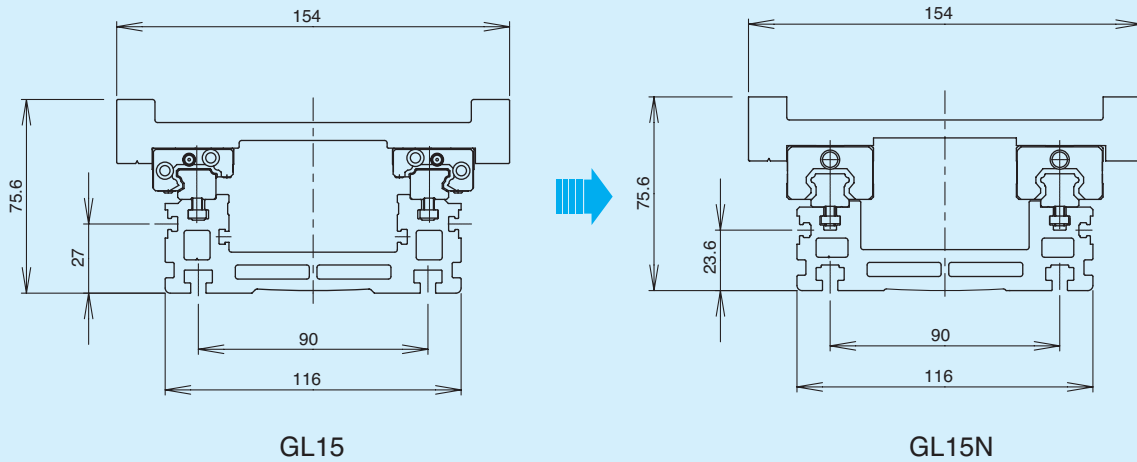

Figure 5 Cross-section comparative views

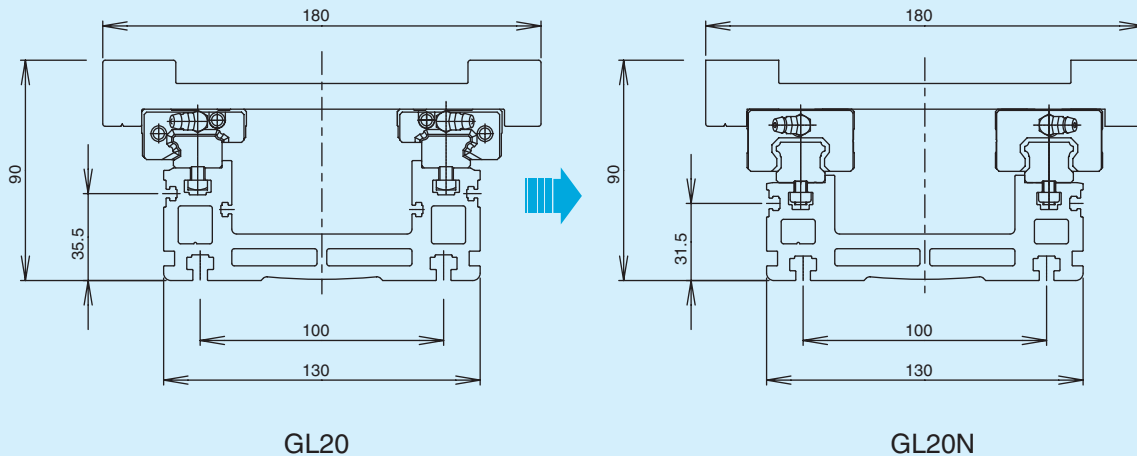

Figure 6 Cross-section comparative views

# Types and Features

## Types of Drive Systems

### [Ball Screw Drive]

#### Direct Mounting

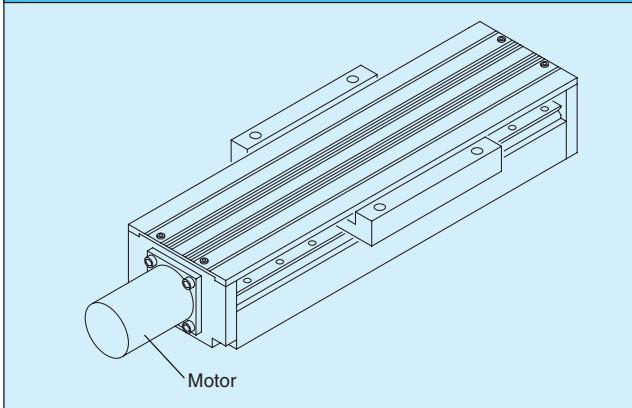

Direct mounting of Motor to Ball Screw.

#### Lateral wrap-around Option

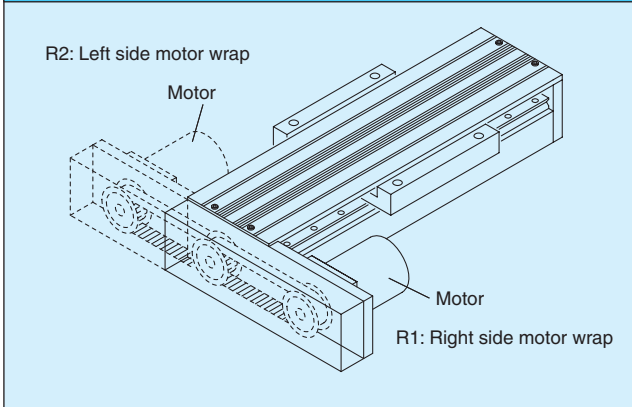

Axial dimensions are kept to minimum by applying the Wrap-Around option.  
(Pulley ratio: 1:1)

#### Bottom wrap-around Option

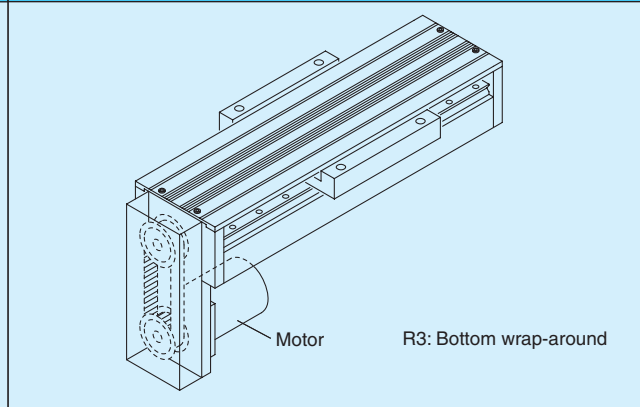

When horizontal space is at a minimum, the bottom side Wrap-Around option is available.  
(Pulley ratio: 1:1)

### [Timing Belt Type]

#### Horizontal Mounting

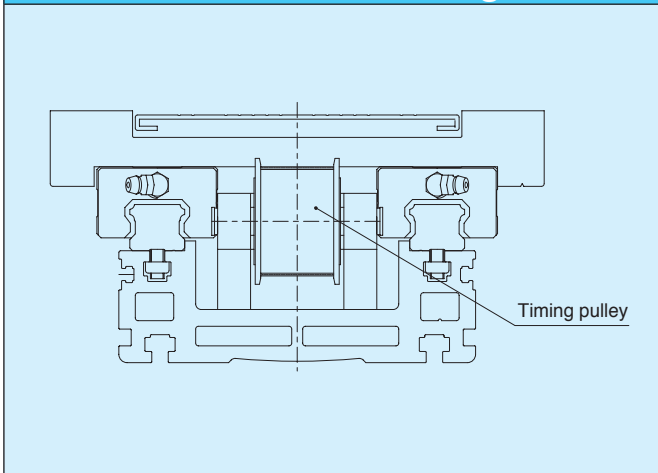

Note 1: Please mount Model GL-N horizontally. Contact THK if Model GL-N will be mounted on a wall.

Note 2: Please note that Model GL-N with timing belts cannot be mounted vertically.

## Specification

Model number		GL15N						GL20N																			
		Ball Screw			Belt			Ball Screw			Belt																
Drive system		5			10			16			20		30		-			5		10		20		40		-	
Screw lead (mm)		5			10			16			20		30		-			5		10		20		40		-	
Pulley pitch diameter (mm)		-			-			-			35.01		-			-		-		-		-		38.20		-	
Repeatability <sup>Note 1)</sup> (mm)		±0.02			±0.02			±0.02			±0.02			±0.02			±0.08		±0.08		±0.08		±0.08		±0.08		
Effective stroke <sup>Note 2)</sup> (mm)		100 to 1200			100 to 1200			50 to 1700			200 to 1550			150 to 2700		-		-		-		-		-		-	
Maximum load capacity guideline <sup>Note 3) Note 4)</sup> [kg]	200W	Horizontal		60	60	50	45	20	30	-	-	-	-	-	-	-	-	-	-	-	-	-	-	-	-	-	
		Vertical		20	16	10	10	3	-	-	-	-	-	-	-	-	-	-	-	-	-	-	-	-	-	-	
	400W	Horizontal		-	-	-	-	-	-	-	70	70	60	15	50	-	-	-	-	-	-	-	-	-	-	-	
		Vertical		-	-	-	-	-	-	-	30	30	13	6	-	-	-	-	-	-	-	-	-	-	-	-	
Static permissible load <sup>Note 5)</sup> [N]	Reverse radial direction		9600						14300																		
	Horizontal direction		2900						4500																		
	Axial direction		2100			-			2200			-															
Static permissible moment <sup>Note 6)</sup> [N-m]	M <sub>A</sub>		430						710																		
	M <sub>B</sub>		240						430																		
	M <sub>C</sub>		610						1020																		

Note 1: This repeatability is ensured at an ambient temperature of 20°C.

Note 2: The effective stroke decreases depending on the table length. See the dimensional drawings (pages 7 to 14) for stroke details.

Note 3: Maximum load capacity guideline is determined based on rated revolution of the motor at the acceleration of 0.3G.

The motor capacity assumes the use of an AC servomotor.

Note 4: Values for the belt drive type are guidelines when using 1/5 reducers.

Note 5: The static permissible load is determined by the bolt joint strength, and the static rated load of the LM guide unit, ball screw unit and the support bearing.

For safety purposes, please take into consideration that the strength of the actuator mounting unit is not included.

Note 6: The static permissible moment is the maximum value of the moment in each direction.

For details on fatigue life, see "Service Life Time and Static Safety Factor" on pages 25 to 26.

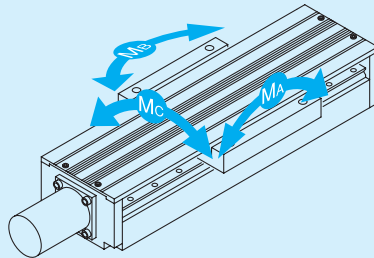

MA : Pitching direction

MB : Yawing direction

MC : Rolling direction

Figure 7 Directions of static permissible moment

## Types of Tables

### S type: Short table (applicable LM Guide model number: SSR-XV)

A short table length ensures a longer stroke.

### L type: Long table (applicable LM Guide model number: SSR-XW, and SHS-V)

This table is suitable for mounting large sized objects or if the load is off center.

### L-QZ type: Long table with an LM Guide QZ Lubricator (applicable LM Guide model numbers: SSR-XWQZ and SHS-VQZ)

The LM Guide is provided with a QZ Lubricator. (This table is longer than the L-type table. See dimensional drawings for more details.)

Note: QZ lubricator is not available for S type table option.

## Maximum Travel Speed of the LM Actuator

### Ball Screw Type

Ball Screws have an allowable rotational speed based on the DN value and the critical speed.

The table travel speed (mm/s) of the LM Actuator depends on the rotational speed of the Ball Screw and the rated rpm (3000 min<sup>-1</sup>) of the AC servo motor.

### Maximum travel speed

Unit: mm/s

Nominal model number	Ball Screw lead	GL15N					GL20N			
		5	10	16	20	30	5	10	20	40
Base length	340	248	500	800	1000	1500	-	-	-	-
	460	248	500	800	1000	1500	202	500	1000	2000
	580	248	500	800	1000	1500	202	500	1000	2000
	700	248	500	800	1000	1500	202	500	1000	2000
	820	248	500	800	1000	1500	202	500	1000	2000
	1060	207	391	685	776	1175	202	396	1000	2000
	1240	144	271	474	540	815	185	275	763	1533
	1420	105	198	349	396	595	136	201	560	1120
	1600	-	-	-	-	-	104	-	426	860
1780	-	-	-	-	-	82	-	336	673	

Note: The LM actuator may not reach the maximum travel speed if the moving distance is short.

### Timing Belt Type

The table shown below summarizes the table travel speed (mm/s) of when the LM Actuator is equipped with a reducer and the AC servo motor is operated at a rated rpm (3000min<sup>-1</sup>).

### Maximum travel speed

Unit: mm/s

Nominal model number	Reduction ratio	GL15N			GL20N		
		1/3	1/5	1/9	1/3	1/5	1/9
Maximum travel speed		1833	1100	611	2000	1200	667

## Nominal Model Numbers

### Ball Screw type specification

**GL20N - 070 - SW Q - B20 Q R1 - B14 - C - A - A - Y**

①                      ②                      ③                      ④                      ⑤                      ⑥                      ⑦                      ⑧                      ⑪                      ⑫                      ⑬                      ⑭

### Belt type specification

**GL20N - 070 - SW Q - EH - B1 - G1 - 03 - C - A - A - Y**

①                      ②                      ③                      ④                      ⑤                      ⑧                      ⑨                      ⑩                      ⑪                      ⑫                      ⑬                      ⑭

① Nominal model number	GL15N/GL20N		
② Base length	Example) For 340 mm: 034	Standard base lengths shown on page 7 to 14	
③ LM Guide	SV: SSR-XV (S-type table) HV: SHS-V (L-type table) (L-QZ type table for SSR/SHS with QZ)	SW: SSR-XW (L-type table)	
④ LM Guide QZ Lubricator	No mark: Not provided with QZ	Q: Provided with QZ (SSR-XW/SHS only)	
⑤ Driving system	<ul style="list-style-type: none"> <li>◆ Ball Screw-driven                             <ul style="list-style-type: none"> <li>B05: Ball Screw lead 5 mm (GL15/20)</li> <li>B20: Ball Screw lead 20 mm (GL20)</li> <li>B30: Ball Screw lead 30 mm (GL15 only)</li> <li>B40: Ball Screw lead 40 mm (GL20 only)</li> </ul> </li> <li>◆ Belt-driven                             <ul style="list-style-type: none"> <li>EH: Horizontal model specification</li> </ul> </li> </ul>		
⑥ Ball Screw QZ Lubricator	No mark: Not provided with QZ	Q: Provided with QZ (SSR-XW/SHS only) <small>* Ball Screw leads (30 mm and 40 mm) are excluded for wiper rings.</small>	
⑦ Ball Screw driven motor mount method	No mark: Direct mounting	R1: Right side motor wrap	R2: Left side motor wrap      R3: Bottom
⑧ Ball Screw drive End plate type	<ul style="list-style-type: none"> <li>◆ Ball Screw specification for direct motor connection                             <ul style="list-style-type: none"> <li>A: inner diameter ø30H7, M4, PCD46</li> <li>B: inner diameter ø50H7, M5, PCD70</li> <li>C: inner diameter ø50H7, M4, PCD60</li> <li>D: inner diameter ø70H7, M5, PCD90 (GL20 only)</li> <li>E: inner diameter ø30H7, M3, PCD45</li> <li>T: inner diameter ø22, counter bore for M3 from rear, mounting pitch 31 (NEMA17 standard) (GL15 only)</li> <li>U: inner diameter ø38.1, M4, mounting pitch 47.14 (NEMA23 standard)</li> <li>V: inner diameter ø73.03, M5, mounting pitch 69.6 (NEMA34 standard) (GL20 only)</li> <li>W: inner diameter ø40, M5, PCD63</li> <li>F: inner diameter ø50H7, M4, PCD70</li> <li>G: inner diameter ø34H7, M3, PCD48</li> <li>H: inner diameter ø36H7, M4, mounting aperture pitch 50</li> <li>I: inner diameter ø60H7, M6, mounting aperture pitch 70 (GL20 only)</li> <li>J: inner diameter ø70H7, M6, PCD90 (GL20 only)</li> </ul> </li> <li>◆ Ball Screw specification for motor wrap-around                             <ul style="list-style-type: none"> <li>B14: inner diameter ø50, M5, PCD70, pulley inner diameter ø14</li> <li>D11: inner diameter ø70, M5, PCD90, pulley inner diameter ø11</li> <li>D14: inner diameter ø70, M5, PCD90, pulley inner diameter ø14</li> <li>V11: inner diameter ø73.03, M5, mounting pitch 69.6, pulley inner diameter ø9.35 mm (NEMA34 standard) (GL20 only)</li> <li>F11: inner diameter ø50, M4, PCD70, pulley inner diameter ø11</li> <li>F14: inner diameter ø50, M4, PCD70, pulley inner diameter ø14</li> <li>J14: inner diameter ø70, M6, PCD90, pulley inner diameter ø14</li> </ul> </li> <li>◆ Belt specification for motor bracket                             <ul style="list-style-type: none"> <li>N: No motor bracket</li> <li>B1: inner diameter ø50, ø5.5, PCD60</li> <li>B2: inner diameter ø60, ø6.5, PCD90</li> <li>U1: inner diameter ø38.1, M4 (NEMA23 standard)</li> <li>V1: inner diameter ø73.03, M5 (NEMA34 standard) (GL20 only)</li> </ul> </li> </ul>		
Timing belt drive Motor bracket type			
⑨ Reducer	<ul style="list-style-type: none"> <li>◆ Reducer specification for belt drive (motor bracket, only available for B1 and B2)</li> <li>Reducer symbols: G1, G2, G3, G4, G5, G6, G7, G8 and G9</li> <li>* See page 19 for details of the reducer symbols and available motors.</li> <li>Note: When ordering a belt drive with reducer inform us of the model number of the motor to which it is to be attached. (Please indicate combined motor for selecting gear head interface.)</li> <li>No mark: Not provided with reducer.</li> </ul>		
⑩ Reduction ratio	Reduction ratio: 03: 1/3    05: 1/5    09: 1/9 Note: Model number display example: B1G103 (motor bracket B1 + reducer G1 + reduction ratio 1/3) No mark: Not provided with reducer.		
⑪ Covers and bellows <small>Note2)</small>	N: Not provided	C: Cover provided	J: Bellow provided
⑫ Sensors	N : None      A: Photo sensor EE-SX671 (3 pcs)      B: Photo sensor EE-SX674 (3 pcs) C1: Proximity sensor TL-W3MC1 (N.O.x3) C2: Proximity sensor TL-W3MC1 (N.O.x1), TL-W3MC2 (N.C.x2) C3: TL-W3MB1(N.O.x3) C4: TL-W3MB1(N.O.x1), TL-W3MB2(N.C.x2)		
⑬ Cable carrier	N: None A: TKP0180W40R28 (Tsubakimoto Chain Co.) B: TKP0180W40R37 (Tsubakimoto Chain Co.) C: TKP0180W40R50 (Tsubakimoto Chain Co.) D: TKP0320W24R37 (Tsubakimoto Chain Co.) E: TKP0320W24R50 (Tsubakimoto Chain Co.) F: TKP0320W24R75 (Tsubakimoto Chain Co.) G: TKP0320W50R37 (Tsubakimoto Chain Co.) H: TKP0320W50R50 (Tsubakimoto Chain Co.) I: TKP0320W50R75 (Tsubakimoto Chain Co.)		
⑭ Mounting hole	Y: Standard mounting counter bore		

Note 1: Items with cyan marker indicate standard options at this time.

Note 2: Cover is applied up to 1960mm base length.

# Ball Screw Driven Dimensions

## GL15N Model, Ball Screw Driven

### [Direct Mounting Specification]

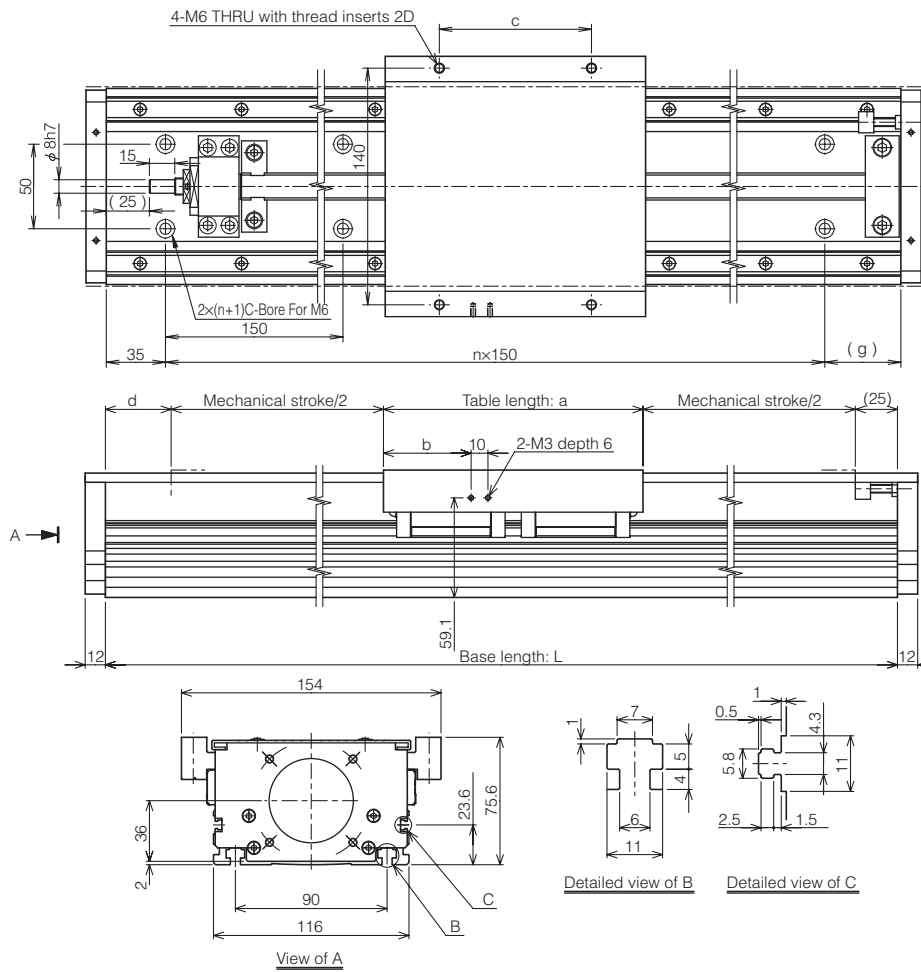

Unit: mm

Table type	Table length: a	b	c	d
S type	126	38	90	53
L type	154	52	90	39
L(QZ) type	154	52	90	48
L-QZ type	180	65	120	21

Base length: L [mm]		340	460	580	700	820	1060	1240	1420	
Mechanical stroke [mm]	Table	S type	136	256	376	496	616	856	1036	1216
		L type	122	242	362	482	602	842	1022	1202
		L(QZ) type	113	233	353	473	593	833	1013	1193
		L-QZ type	114	234	354	474	594	834	1014	1194
Main unit weight [kg]	Table	S type	5.8	6.9	8.0	9.2	10.3	12.5	14.2	15.9
		L type (SSR15XW)	6.1	7.2	8.3	9.5	10.6	12.8	14.5	16.2
		L type (SHS15V)	6.5	7.6	8.8	9.9	11.1	13.4	15.1	16.8
Base mounting hole		n	1	2	3	4	5	6	7	9
		g	155	125	95	65	35	125	155	35

Note 1: The main unit weight includes the cover weight.

Note 2: The table L(QZ) type shows a QZ specification only for the Ball Screw.

Note 3: The main unit weight of the QZ type is the main unit weight of the table +0.1kg.

# GL15N Model, Ball Screw Driven

## [Lateral Wrap-around Specification]

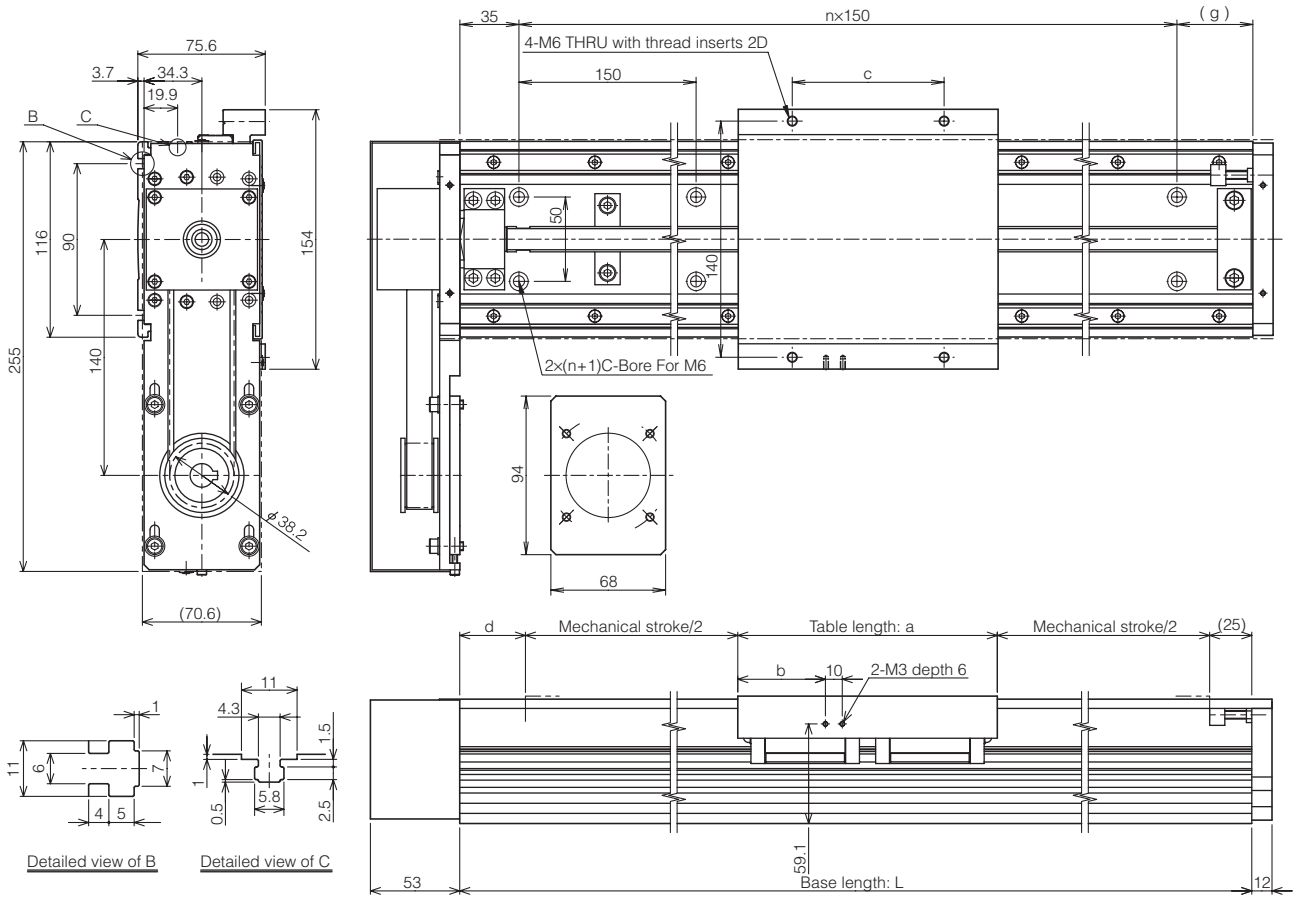

Unit: mm

Table type	Table length: a	b	c	d
S type	126	38	90	53
L type	154	52	90	39
L(QZ) type	154	52	90	48
L-QZ type	180	65	120	21

Base length: L [mm]		340	460	580	700	820	1060	1240	1420	
Mechanical stroke [mm]	Table	S type	136	256	376	496	616	856	1036	1216
		L type	122	242	362	482	602	842	1022	1202
		L(QZ) type	113	233	353	473	593	833	1013	1193
		L-QZ type	114	234	354	474	594	834	1014	1194
Main unit weight [kg]	Table	S type	7.4	8.5	9.6	10.8	11.9	14.1	15.8	17.5
		L type (SSR15XW)	7.7	8.8	9.9	11.1	12.2	14.4	16.1	17.8
		L type (SHS15V)	8.1	9.2	10.4	11.5	12.7	15.0	16.7	18.4
Base mounting hole	n	1	2	3	4	5	6	7	9	
	g	155	125	95	65	35	125	155	35	

Note 1: The main unit weight includes the cover weight.

Note 2: The table L(QZ) type shows a QZ specification only for the Ball Screw.

Note 3: The main unit weight of the QZ type is the main unit weight of the table + 0.1kg.

[Bottom Wrap-around Specification]

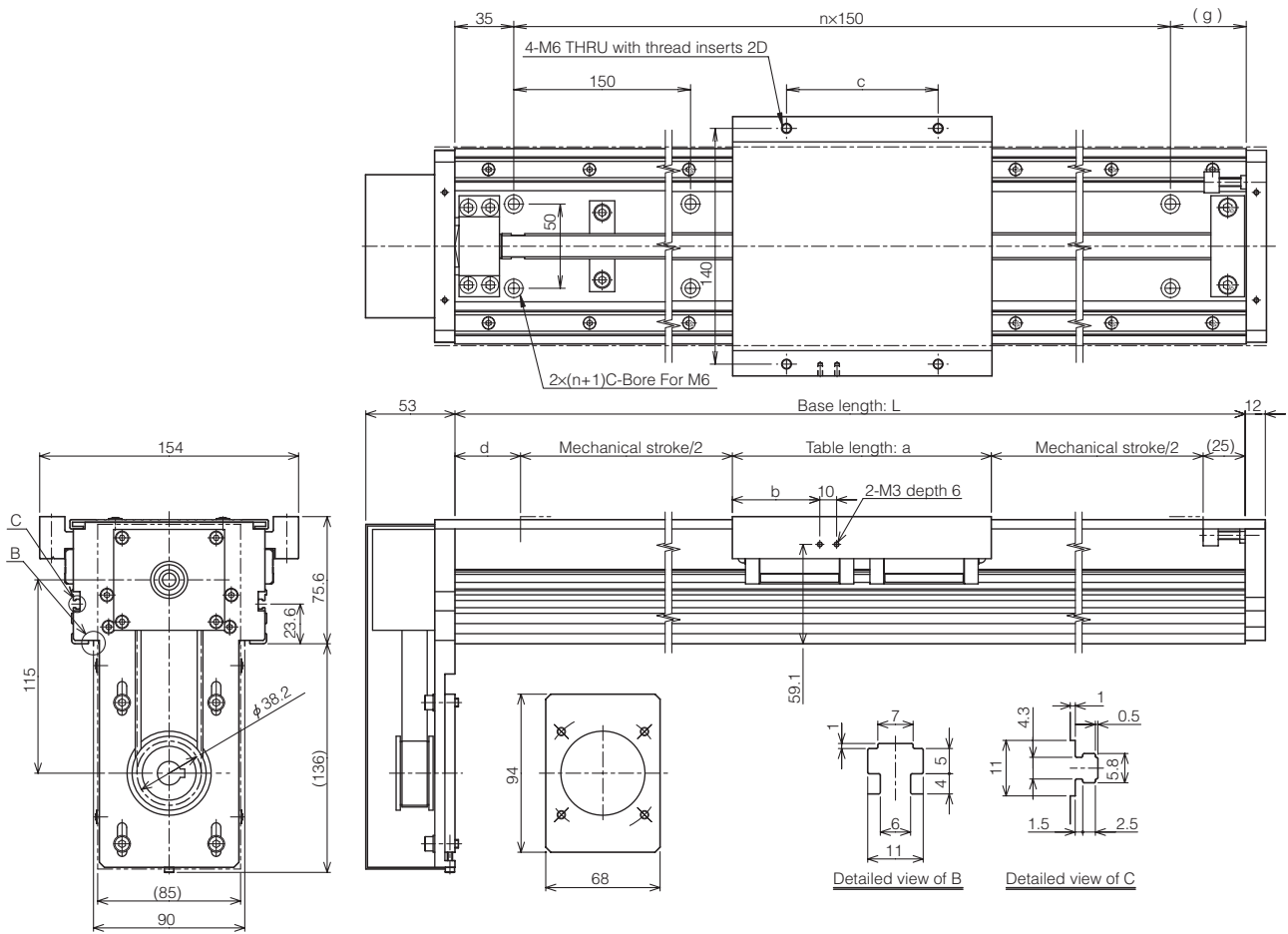

Unit: mm

Table type	Table length: a	b	c	d
S type	126	38	90	53
L type	154	52	90	39
L(QZ) type	154	52	90	48
L-QZ type	180	65	120	21

Base length: L [mm]		340	460	580	700	820	1060	1240	1420
Mechanical stroke [mm]	Table								
	S type	136	256	376	496	616	856	1036	1216
	L type	122	242	362	482	602	842	1022	1202
	L(QZ) type	113	233	353	473	593	833	1013	1193
Main unit weight [kg]	Table								
	S type	7.4	8.5	9.6	10.8	11.9	14.1	15.8	17.5
	L type (SSR15XW)	7.7	8.8	9.9	11.1	12.2	14.4	16.1	17.8
Base mounting hole	L type (SHS15V)	8.1	9.2	10.4	11.5	12.7	15.0	16.7	18.4
	n	1	2	3	4	5	6	7	9
	g	155	125	95	65	35	125	155	35

Note 1: The main unit weight includes the cover weight.

Note 2: The table L(QZ) type shows a QZ specification only for the Ball Screw.

Note 3: The main unit weight of the QZ type is the main unit weight of the table +0.1kg.

[Direct Mounting Specification]

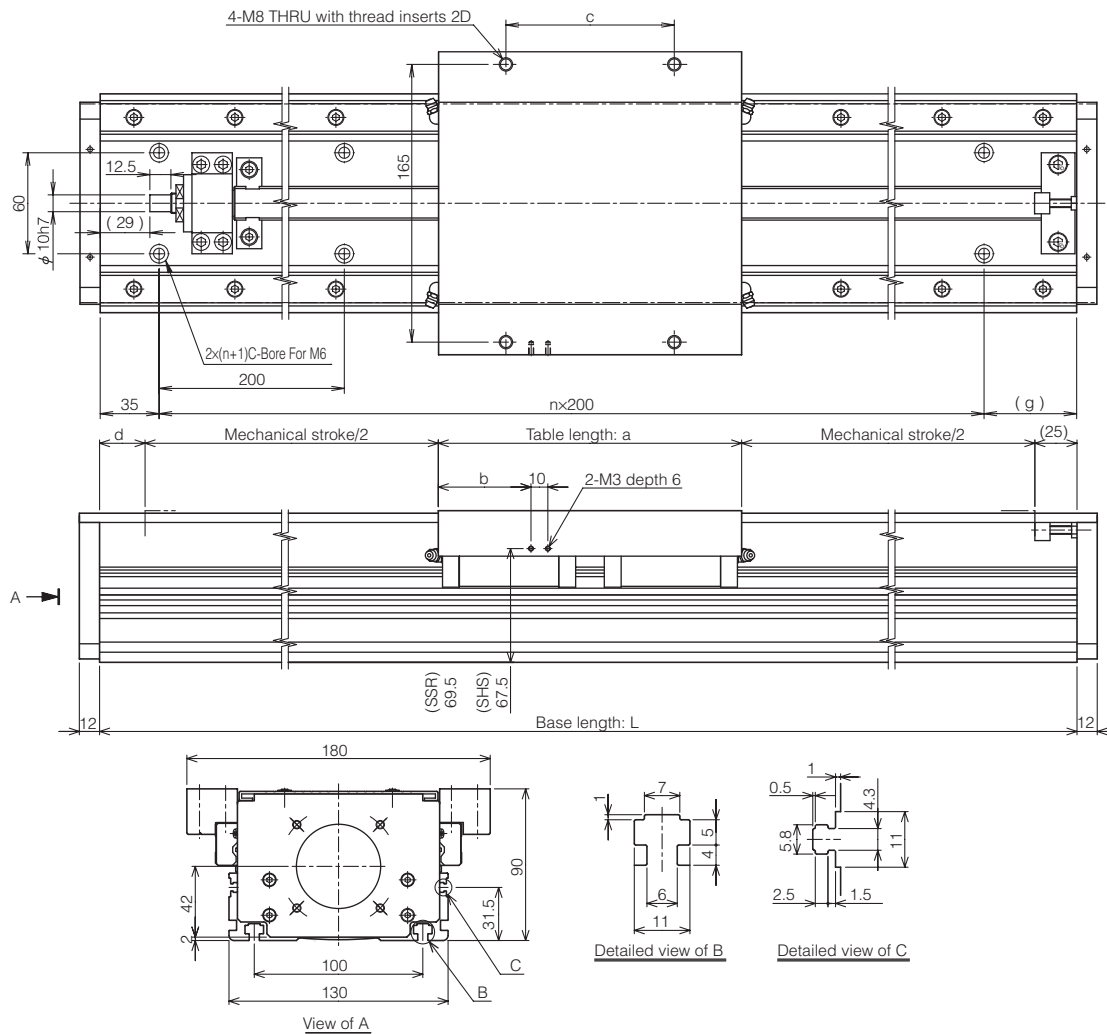

Unit: mm

Table type	Table length: a	b	c	d
S type	160	45	100	37
L type	180	55	100	27
L(QZ) type	180	55	100	34
L-QZ type	210	70	150	5

Base length: L [mm]		460	580	700	820	1060	1240	1420	1600	1780	
Mechanical stroke [mm]	Table	S type	238	358	478	598	838	1018	1198	1378	1558
		L type	228	348	468	588	828	1008	1188	1368	1548
		L(QZ) type	221	341	461	581	821	1001	1181	1361	1541
		L-QZ type	220	340	460	580	820	1000	1180	1360	1540
Main unit weight [kg]	Table	S type	9.9	11.5	13.2	14.8	18.1	20.6	23.1	25.5	28.0
		L type (SSR20XW)	10.4	12.0	13.7	15.3	18.6	21.1	23.6	26.0	28.5
		L type (SHS20V)	11.2	12.9	14.6	16.3	19.7	22.2	24.7	27.3	29.8
Base mounting hole	n	1	2	3	3	4	5	6	7	8	
	g	225	145	65	185	225	205	185	165	145	

Note 1: The main unit weight includes the cover weight.

Note 2: The table L(QZ) type shows a QZ specification only for the Ball Screw.

Note 3: The main unit weight of the QZ type is the main unit weight of the table +0.1kg.

Note 4: The maximum base length for the 10mm ball screw lead is 1420mm.

[Lateral Wrap-around Specification]

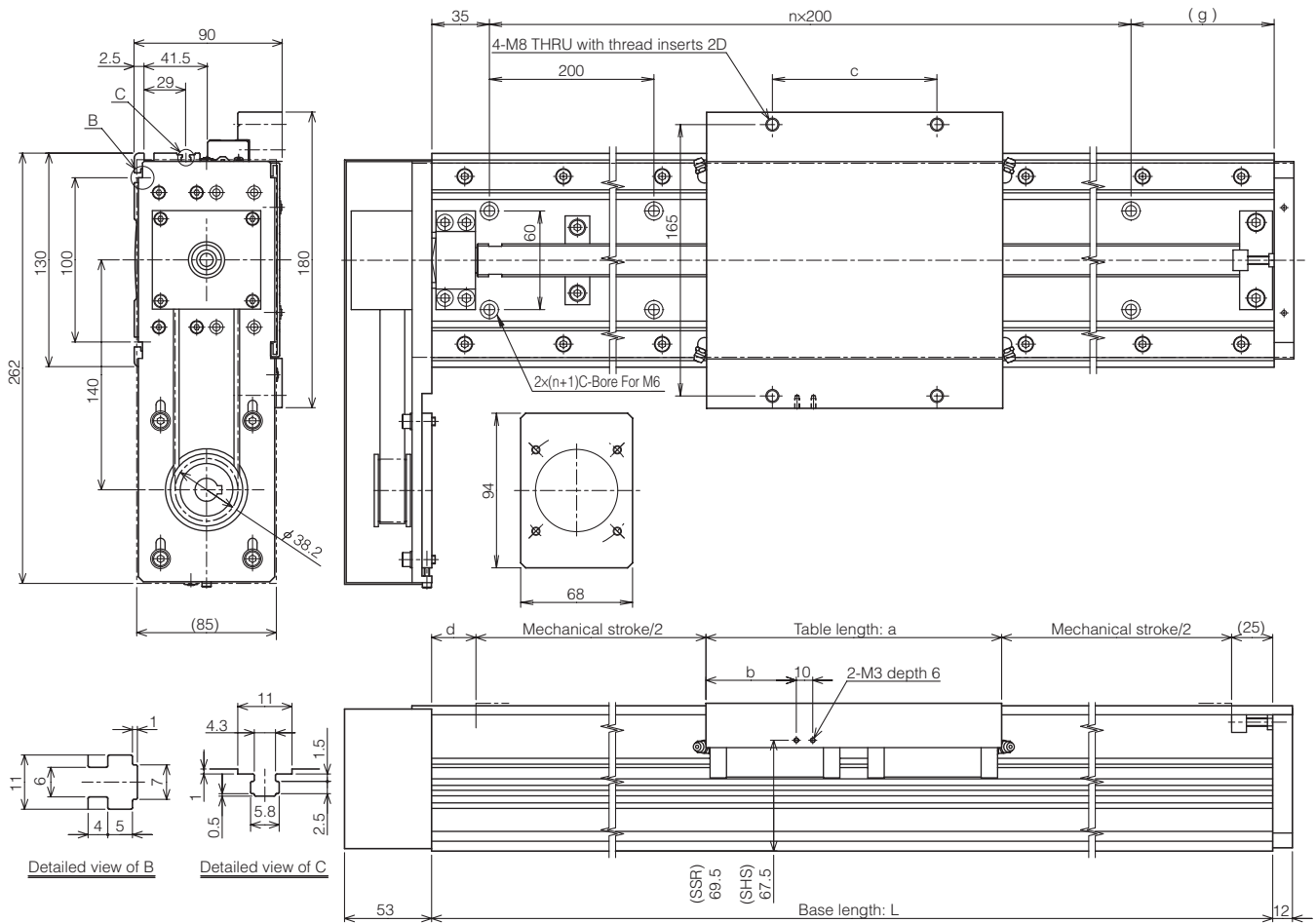

Unit: mm

Table type	Table length: a	b	c	d
S type	160	45	100	37
L type	180	55	100	27
L(QZ) type	180	55	100	34
L-QZ type	210	70	150	5

Base length: L [mm]		460	580	700	820	1060	1240	1420	1600	1780
Mechanical stroke [mm]	Table	S type	238	358	478	598	838	1018	1198	1558
	L type	228	348	468	588	828	1008	1188	1368	1548
	L(QZ) type	221	341	461	581	821	1001	1181	1361	1541
	L-QZ type	220	340	460	580	820	1000	1180	1360	1540
Main unit weight [kg]	Table	S type	11.8	13.4	15.1	16.7	20.0	22.5	25.0	29.9
	L type (SSR20XW)	12.3	13.9	15.6	17.2	20.5	23.0	25.5	27.9	30.4
	L type (SHS20V)	13.1	14.8	16.5	18.2	21.6	24.1	26.6	29.2	31.7
Base mounting hole	n	1	2	3	3	4	5	6	7	8
	g	225	145	65	185	225	205	185	165	145

Note 1: The main unit weight includes the cover weight.

Note 2: The table L(QZ) type shows a QZ specification only for the Ball Screw.

Note 3: The main unit weight of the QZ type is the main unit weight of the table +0.1kg.

Note 4: The maximum base length for the 10mm ball screw lead is 1420mm.

[Bottom Wrap-around Specification]

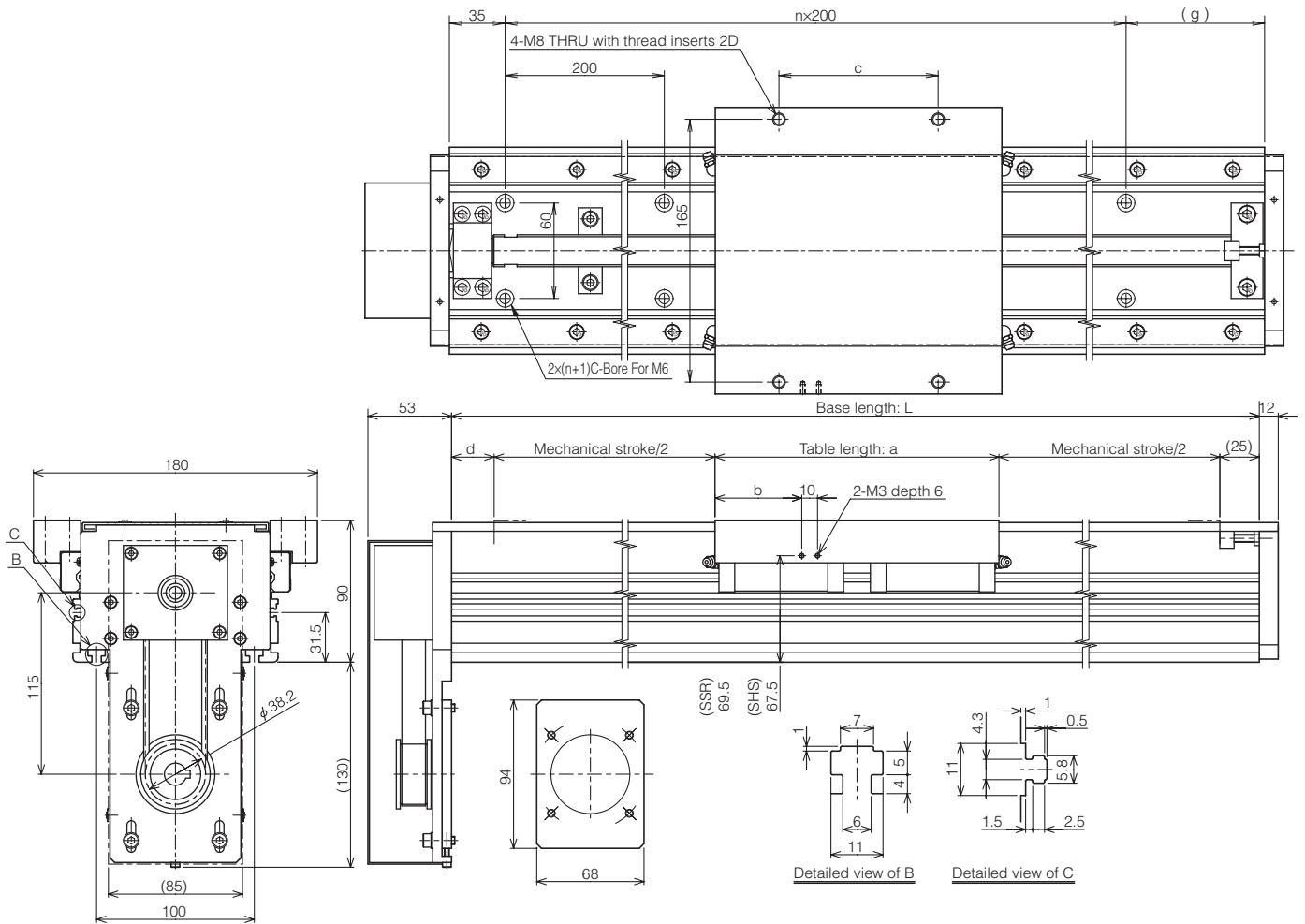

Unit: mm

Table type	Table length: a	b	c	d
S type	160	45	100	37
L type	180	55	100	27
L(QZ) type	180	55	100	34
L-QZ type	210	70	150	5

Base length: L [mm]		460	580	700	820	1060	1240	1420	1600	1780
Mechanical stroke [mm]	S type	238	358	478	598	838	1018	1198	1378	1558
	L type	228	348	468	588	828	1008	1188	1368	1548
	L(QZ) type	221	341	461	581	821	1001	1181	1361	1541
	L-QZ type	220	340	460	580	820	1000	1180	1360	1540
Main unit weight [kg]	S type	11.8	13.4	15.1	16.7	20.0	22.5	25.0	27.4	29.9
	L type (SSR20XW)	12.3	13.9	15.6	17.2	20.5	23.0	25.5	27.9	30.4
	L type (SHS20V)	13.1	14.8	16.5	18.2	21.6	24.1	26.6	29.2	31.7
Base mounting hole	n	1	2	3	3	4	5	6	7	8
	g	225	145	65	185	225	205	185	165	145

Note 1: The main unit weight includes the cover weight.

Note 2: The table L(QZ) type shows a QZ specification only for the Ball Screw.

Note 3: The main unit weight of the QZ type is the main unit weight of the table +0.1kg.

Note 4: The maximum base length for the 10mm ball screw lead is 1420mm.

# Belt Driven Dimensions

## GL15N Model, Belt Driven

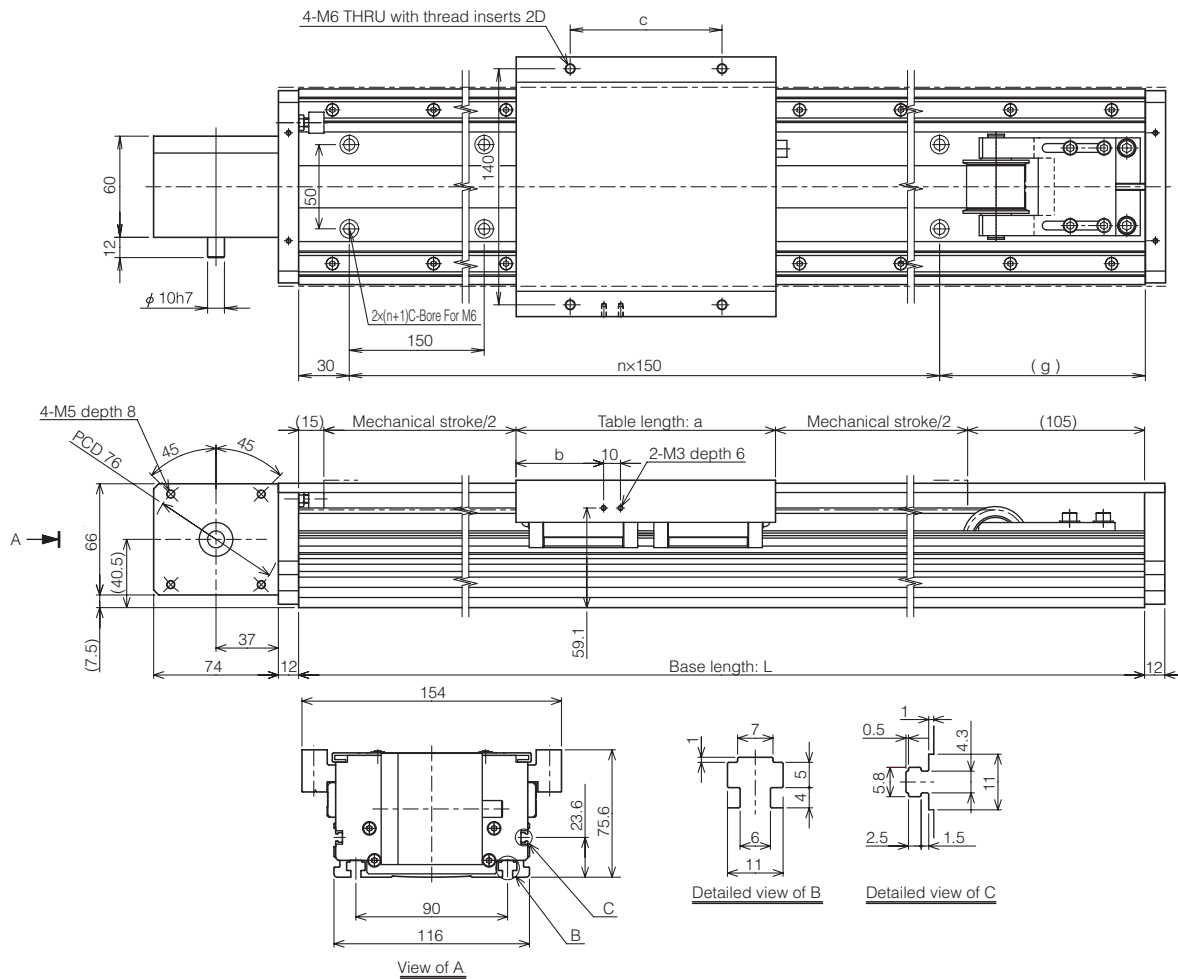

Unit: mm

Table type	Table length: a	b	c
S type	126	38	90
L type	154	52	90
L-QZ type	180	65	120

Base length: L [mm]		340	460	580	700	820	1060	1240	1420	1600	1780	1960
Mechanical stroke [mm]	Table											
	S type	94	214	334	454	574	814	994	1174	1354	1534	1714
	L type	66	186	306	426	546	786	966	1146	1326	1506	1686
	L-QZ type	40	160	280	400	520	760	940	1120	1300	1480	1660
Main unit weight [kg]	Table											
	S type	7.1	8.1	9.1	10.1	11.1	13.1	14.5	16.0	17.5	19.0	20.5
	L type (SSR15XW)	7.4	8.4	9.4	10.4	11.4	13.4	14.8	16.3	17.8	19.3	20.8
	L type (SHS15V)	7.8	8.8	9.8	10.9	11.9	13.9	15.4	16.9	18.5	20.0	21.5
Base mounting hole	n	1	2	3	3	4	6	7	8	9	11	12
	g	160	130	100	220	190	130	160	190	220	100	130

Note 1: The main unit weight includes the cover weight.

Note 2: The main unit weight of QZ type is the main unit weight of the table +0.1kg.

# GL20N Model, Belt Driven

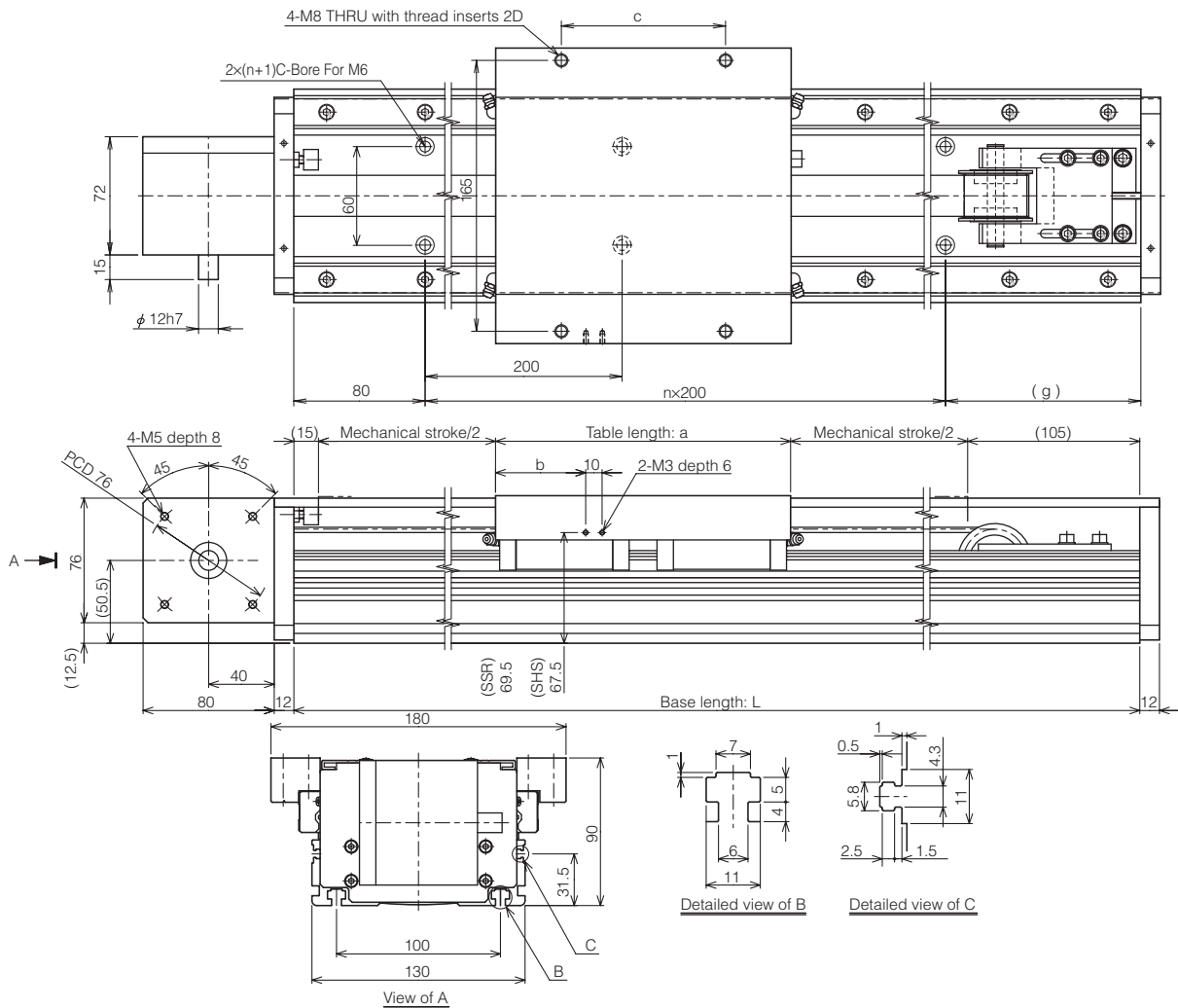

Unit: mm

Table type	Table length: a	b	c
S type	160	45	100
L type	180	55	100
L-QZ type	210	70	150

Base length: L [mm]		460	580	700	820	1060	1240	1420	1600	1780	1960	2200	2320	2500	3000
Mechanical stroke [mm]	S type	180	300	420	540	780	960	1140	1320	1500	1680	1920	2040	2220	2720
	L type	160	280	400	520	760	940	1120	1300	1480	1660	1900	2020	2200	2700
	L-QZ type	130	250	370	490	730	910	1090	1270	1450	1630	1870	1990	2170	2670
Main unit weight [kg]	S type	11.5	12.9	14.3	15.7	18.6	20.7	22.8	24.9	27.0	29.1	31.9	33.3	35.5	41.3
	L type (SSR20XW)	12.0	13.4	14.8	16.2	19.1	21.2	23.3	25.4	27.5	29.6	32.4	33.8	36.0	41.8
	L type (SHS20V)	12.8	14.2	15.7	17.1	20.1	22.2	24.4	26.6	28.8	31.0	33.9	35.4	37.5	43.6
Base mounting hole	n	1	1	2	3	4	5	6	7	8	8	10	10	11	14
	g	180	300	220	140	180	160	140	120	100	280	120	240	220	120

Note 1: The main unit weight includes the cover weight.

Note 2: The main unit weight of QZ type is the main unit weight of the table + 0.1kg.

Note 3: Cover is applied up to 1960mm base length.

### [LM Guide]

QZ Lubricator, composed of high-density fiber net feeds the right amount of lubricant to the raceway of the LM rail. This allows oil film to continuously be formed between balls and raceways and significantly extends the lubrication and maintenance intervals.

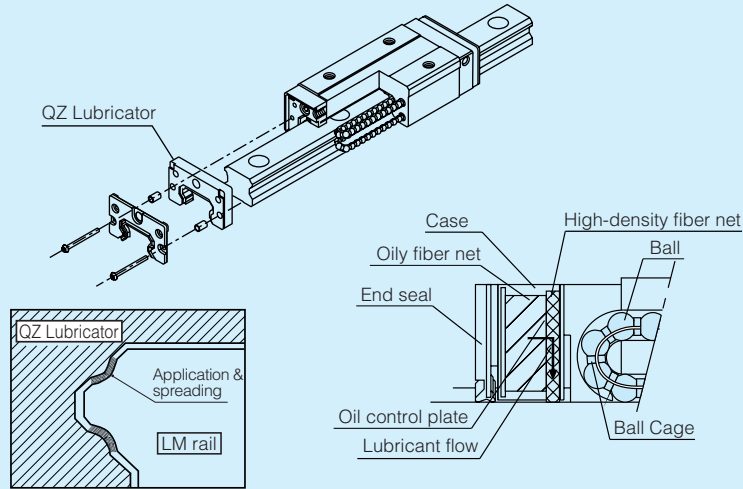

**Figure 8 QZ Lubricator Structure Diagram (LM Guide)**

### [Ball Screw]

An adequate amount of lubricant can be supplied to necessary locations as in the LM Guide portion so that maintenance interval can be greatly extended.

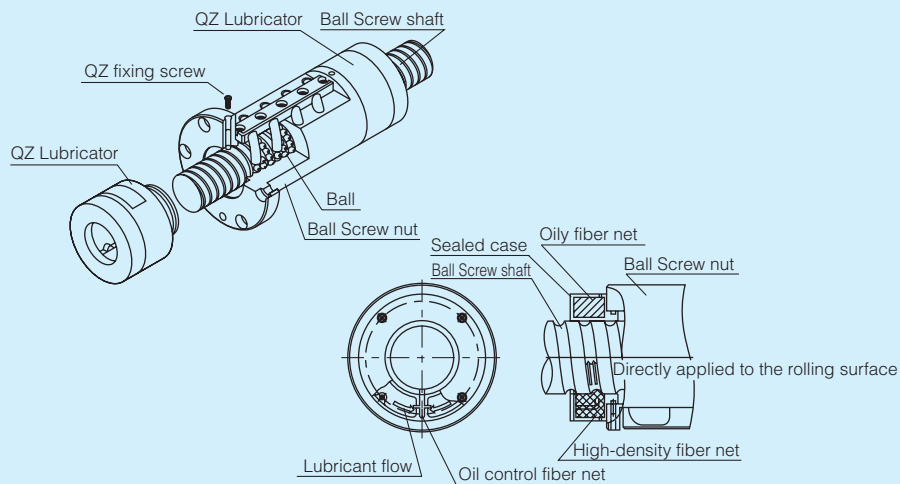

**Figure 9 QZ Lubricator Structure Diagram (Ball Screw)**

[Control Number]

Motor brackets are available to mount various types of motors. The following table lists by model number the motor brackets available for motors. When purchasing a motor bracket, specify the corresponding model number.

Table 4 Motors and Applicable motor Brackets

		Motor				GL15N		GL20N			
		Manufacturer	Series	Model number	Rated output	Flange angle	Direct motor mounting	Wrap-around	Direct motor mounting	Wrap-around	
AC Servo motor	YASKAWA Electric Corporation	Σ-V		SGMJV-01	100W	□40	A	—	A	—	
				SGMAV-01			A	—	A	—	
			200W	□60	SGMJV-02	B	B14	B	B14		
					SGMAV-02	B	B14	B	B14		
				400W	—	—	B	B14			
					—	—	B	B14			
			Σ-III	□40	SGMAS-01	100W	A	—	A	—	
					SGMPS-01	100W	B	—	B	—	
				□60	SGMAS-02	200W	B	B14	B	B14	
					SGMAS-04	400W	—	—	B	B14	
		400W		—	—	—	—	J	J14		
				—	—	—	—	J	J14		
		Σ-II	□40	SGMAH-01	100W	A	—	A	—		
				SGMPH-01	100W	B	—	B	—		
			□60	SGMAH-02	200W	B	B14	B	B14		
				SGMAH-04	400W	—	—	B	B14		
			400W	—	—	—	—	J	J14		
				—	—	—	—	J	J14		
		Mitsubishi Electric Corporation	MELSERVO	J3	100W	HF-MP13	□40	A	—	A	—
						HF-KP13		A	—	A	—
	200W				□60	HF-MP23	B	B14	B	B14	
						HF-KP23	B	B14	B	B14	
						HF-MP43	—	—	B	B14	
	J2-Super		100W	□40	HC-MFS13	A	—	A	—		
					HC-KFS13	A	—	A	—		
			200W	□60	HC-MFS23	B	B14	B	B14		
					HC-KFS23	B	B14	B	B14		
					HC-MFS43	—	—	B	B14		
	Panasonic Corporation	MINAS A4	100W	□38	MSMD01	E	—	E	—		
					MQMA01	F	—	F	—		
			200W	□60	MSMD02	F	F11	F	F11		
					MSMD04	—	—	F	F14		
					MQMA02	—	—	D	D11		
		400W	□80	MQMA04	—	—	D	D14			
				MINAS A	□38	MSMA01	E	—	E	—	
						MQMA01	F	—	F	—	
				200W	□60	MSMA02	F	F11	F	F11	
						MSMA04	—	—	F	F14	
	MQMA02	—	—			D	D11				
	400W	□80	MQMA04	—	—	D	D14				
OMRON Corporation			OMNUC W	100W	□40	R88M-U10030	A	—	A	—	
						R88M-W10030	A	—	A	—	
	200W	□60		R88M-WP10030	B	—	B	—			
				R88M-U20030	B	B14	B	B14			
				R88M-W20030	B	B14	B	B14			
				R88M-U40030	—	—	B	B14			
	400W	□80		R88M-W40030	—	—	B	B14			
				R88M-WP20030	—	—	J	—			
R88M-WP40030	—	—	J	—							
FANUC	β is series	100W	□40	β 0.3/5000is	A	—	A	—			
				β 0.4/5000is	B	—	B	—			
		200W	□60	β 0.5/5000is	B	B9	B	B9			
				β 1/5000is	—	—	B	B14			
Sanyo Denki Co.,Ltd.	SANMOTION Q1	Q1AA04010D	100W	□40	A	—	A	—			
		Q1AA06020D	200W	□60	B	B14	B	B14			
		Q1AA06040D	400W		—	—	B	B14			
Allen-Bradley	MPL		A1510V	160W	□55	—	—	W	—		
			A1520U	270W		W	—	W	—		
			A1530U	390W		—	—	W	—		
			A210V	370W		—	—	Z	—		
			620W	□70		A220T	—	—	Z	—	
						—	—	—	—	—	
Stepping motor	ORIENTAL MOTOR Co.,Ltd.	5-phase	RK	—	□60	RK564	H	—	H	—	
						RK566	H	—	H	—	
						RK569	H	—	H	—	
						RK596	—	—	I	—	
						RK599	—	—	I	—	
	α step	□60	AS66	H	—	H	—				
			ASC66	H	—	H	—				
			□85	—	—	—	—				
				AS98	—	—	I	—			
			NEMA 17 Standard motor					□42	T	—	—
NEMA 23 Standard motor					□56	U	—	U	—		
NEMA 34 Standard motor					□85	—	—	V	V11		

Note: A motor shaft for motor wrap option will need a key.

[Dimensional Drawing]

• Direct motor mounting

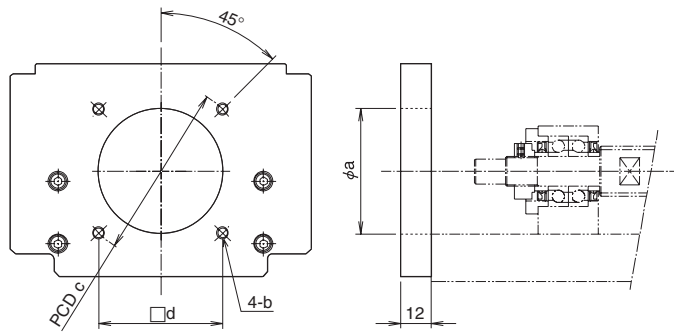
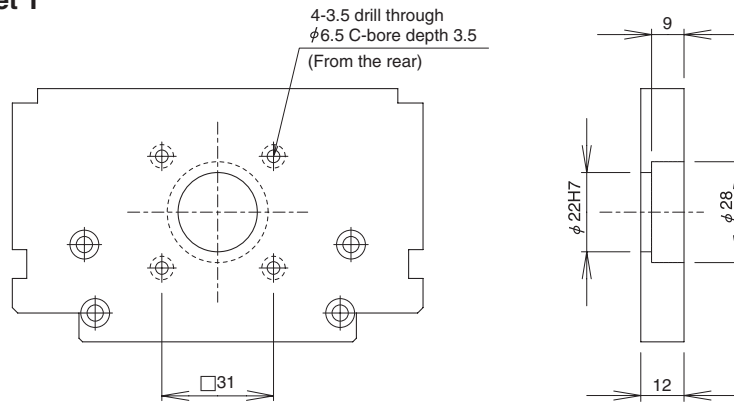

Table 5 Motor Mounting Plate

Unit: mm

Bracket Symbol	Motor mount dimensions			
	a	b	c	d
A	30H7	M4	46	—
B	50H7	M5	70	—
C	50H7	M4	60	—
D	70H7	M5	90	—
E	30H7	M3	45	—
F	50H7	M4	70	—
G	34H7	M3	48	—
H	36H7	M4	—	50
I	60H7	M6	—	70
J	70H7	M6	90	—
U	38.15 <sup>+0.050</sup> <sub>0</sub>	M4	—	47.14
V	73.03H7	M5	—	69.6
W	40H7	M5	63	—
Z	60H7	M5	75	—

• GL15N Motor Bracket T



• Motor wrap-around

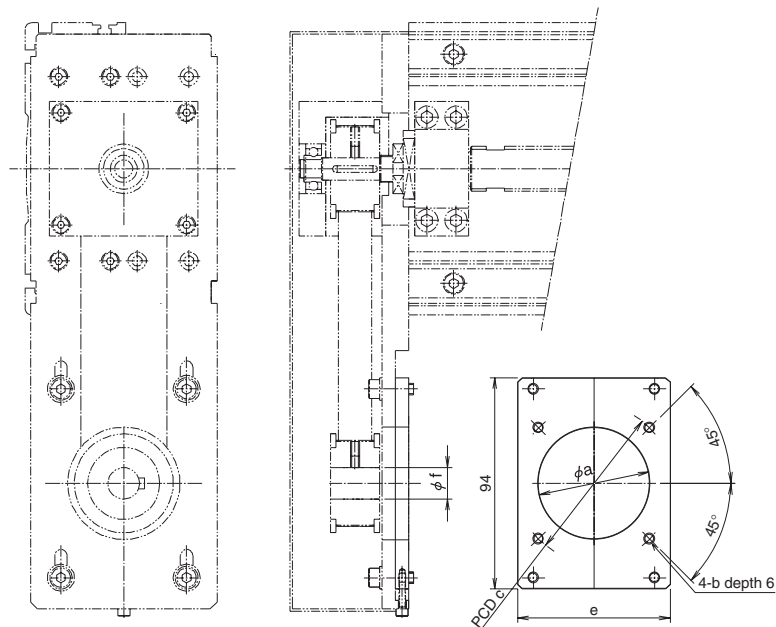

Table 6 Motor Mounting Plate

Unit: mm

Bracket Symbol	Motor mount dimensions				f
	a	b	c	e	
B9	50	M5	70	68	9
B14	50	M5	70	68	14
D11	70	M5	90	80	11
D14	70	M5	90	80	14
F11	50	M4	70	68	11
F14	50	M4	70	68	14
J14	70	M6	90	80	14
V11	73.03	M5	98.43	80	9.53

## Motor Bracket (Belt Type Specification)

### [Control Number]

The following table depicts the motor brackets available for motors with reducers. Please specify the corresponding model number.

Table 7 Reducers and Applicable Motor Brackets

Manufacturer	Series	Reducer			Common to GL15N and GL20N
		Model Number	Rated output	Reduction Ratio	
SHIMPO DRIVES, INC.	VR	VRAFB03	100W	1/3	B1
		VRAFB05		1/5	B1
		VRAFB09		1/9	B1
		VRAFB03	200W	1/3	B1
		VRAFB05		1/5	B1
		VRAFB09		1/9	B1
		VRAFB03	400W	1/3	B1
		VRAFB05		1/5	B1
		VRAFC09		1/9	B2

### [Dimensional Drawing]

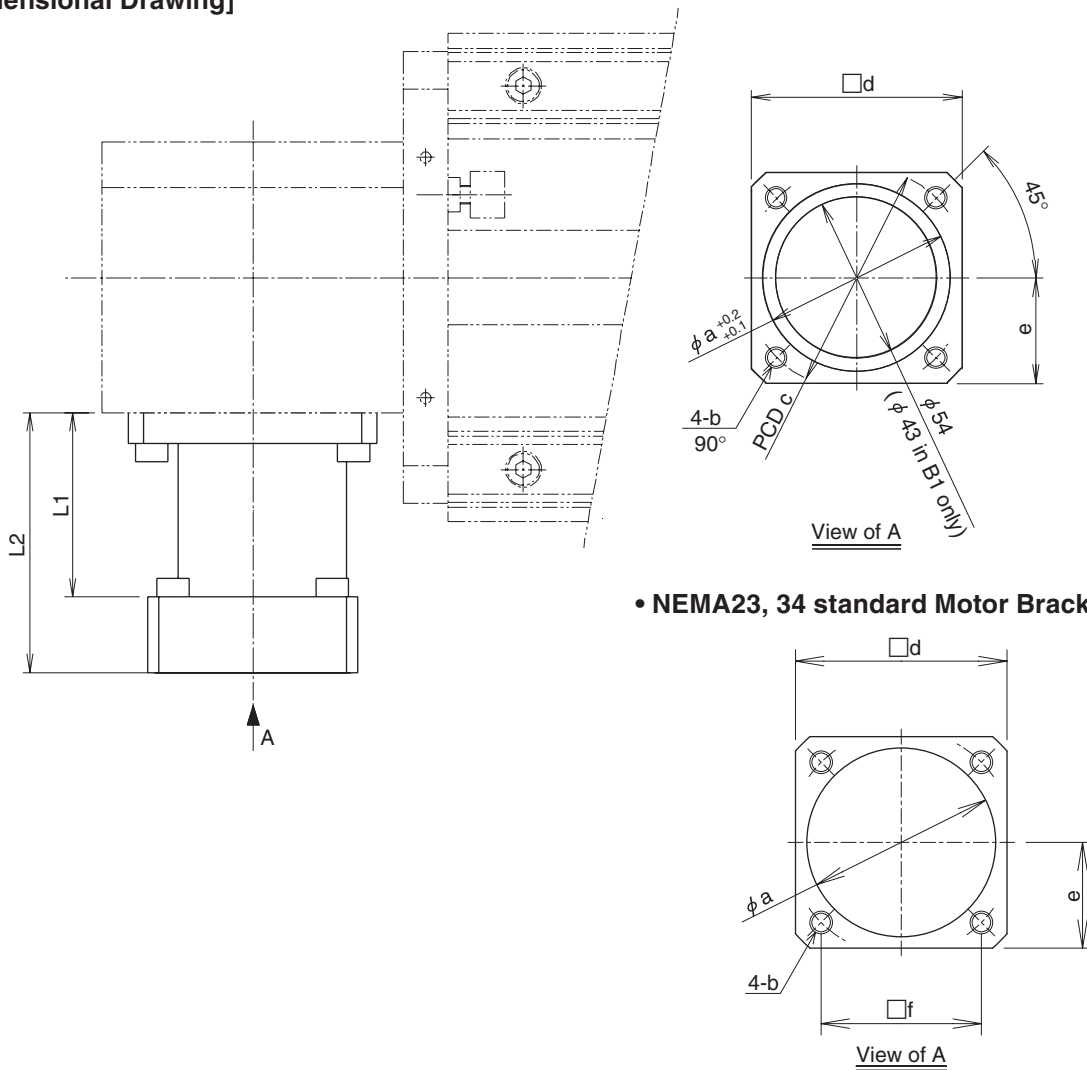

#### • NEMA23, 34 standard Motor Bracket U1, V1

Table 8 Motor Bracket Dimensional Drawing

Unit: mm

Bracket Symbol	Motor bracket dimensions							
	a	b	c	d	e	f	L1	L2
B1	50	5.5 THRU	60	56	28	—	49	69
B2	70	6.6 THRU	90	78	39	—	60	86
U1	38.15	M4 depth 8	—	66	33	47.14	40	48
V1	73.03	M5 depth 10	—	86	43	69.6	48	58

[Control Number]

The following table lists reducers and motors available with motor bracket B1 or B2. It also shows the control numbers of reducers available with the motors. When purchasing a reducer, specify the corresponding control number.

Table 9 Motors and Applicable Reducer

	Motor				Reduction ratio					
	Manufacture	Series	Model number	Rated output	1/3	1/5	1/9			
AC Servo motor	YASKAWA Electric Corporation	Σ-V	SGMAV-01	100W	B1G103	B1G105	B1G109			
			SGMAV-02	200W	B1G303	B1G305	B2G309			
			SGMAV-04	400W	B1G303	B2G305	B2G309			
			SGMAS-01	100W	B1G103	B1G105	B1G109			
		Σ-III	SGMAS-02	200W	B1G303	B1G305	B2G309			
			SGMAS-04	400W	B1G303	B2G305	B2G309			
			SGMAH-01	100W	B1G103	B1G105	B1G109			
			SGMAH-02	200W	B1G303	B1G305	B2G309			
		Σ-II	SGMAH-04	400W	B1G303	B2G305	B2G309			
			Mitsubishi Electric Corporation	MELSERVO	J3	HF-MP13	100W	B1G103	B1G105	B1G109
						HF-KP13		B1G103	B1G105	B1G109
						HF-MP23	200W	B1G303	B1G305	B2G309
	HF-KP23				B1G303	B1G305	B2G309			
	HF-MP43	400W			B1G303	B2G305	B2G309			
	HF-KP43				B1G303	B2G305	B2G309			
	J2-Super	HC-MFS13	100W	B1G103	B1G105	B1G109				
		HC-KFS13		B1G103	B1G105	B1G109				
		HC-MFS23	200W	B1G303	B1G305	B2G309				
		HC-KFS23		B1G303	B1G305	B2G309				
		HC-MFS43	400W	B1G303	B2G305	B2G309				
		HC-KFS43		B1G303	B2G305	B2G309				
	Panasonic Corporation	MINAS A4	MSMD01	100W	B1G203	B1G205	B1G209			
			MSMD02	200W	B1G403	B1G405	B2G409			
			MSMD04	400W	B1G503	B2G505	B2G509			
			MMA01	100W	B1G203	B1G205	B1G209			
		MINAS A	MMA02	200W	B1G403	B1G405	B2G409			
			MUMA02		B1G403	B1G405	B2G409			
			MMA04	400W	B1G503	B2G505	B2G509			
			MUMA04		B1G503	B2G505	B2G509			
	OMRON Corporation	OMNUC W	R88M-U10030	100W	B1G103	B1G105	B1G109			
R88M-W10030				B1G103	B1G105	B1G109				
R88M-U20030			200W	B1G303	B1G305	B2G309				
R88M-W20030				B1G303	B1G305	B2G309				
R88M-U40030			400W	B1G303	B2G305	B2G309				
R88M-W40030				B1G303	B2G305	B2G309				
Sanyo Denki Co.,Ltd.	SANMOTION Q1	Q1AA04010D	100W	B1G103	B1G105	B1G109				
		Q1AA06020D	200W	B1G303	B1G305	B2G309				
		Q1AA06040D	400W	B1G303	B2G305	B2G309				
		TLY-120P (N)	81W	B1G603	B1G605	B1G609				
Allen-Bradley	TLY	TLY-130P (N)	140W	B1G603	B1G605	B1G609				
		TLY-220P (N)	350W	B1G703	B1G705	B2G709				
		TLY-230P (N)	440W	B1G703	B2G705	B2G709				
		A1510V	160W	B1G803	B1G805	B1G809				
	MPL	A1520U	270W	B1G803	B1G805	B2G809				
		A1530U	390W	B1G803	B1G805	B2G809				
		A210V	370W	B2G903	B2G905	B2G909				
		A220T	620W	B2G903	B2G905	B2G909				

Note 1: B1: VRAF-B (SHIMPO DRIVES, INC.); B2: VRAF-C (SHIMPO DRIVES, INC.)

Note 2: When ordering a belt drive with reducer inform us of the model number of the motor to which it is to be attached.

[Dimensional Drawing]

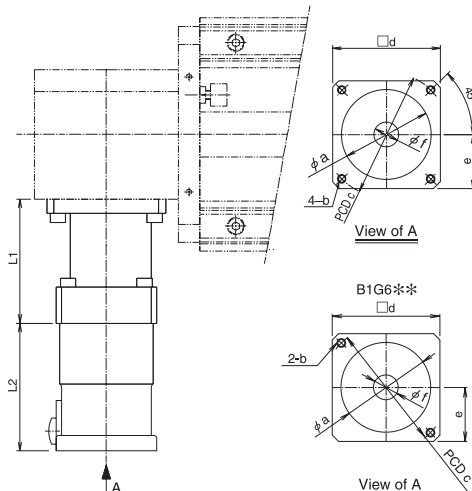

Table 10 Reducer Dimensional Drawing

Unit: mm

Bracket Symbol	Motor bracket dimensions							
	a	b	c	d	e	f	L1	L2
B1G1**	30	M4 depth 10	46	42	21	8	69	67.5
B1G2**	30	M3 depth 8	45	42	21	8	69	67.5
B1G3**	50	M5 depth 10	70	60	30	14	69	72.5
B1G4**	50	M4 depth 10	70	60	30	11	69	72.5
B1G5**	50	M4 depth 10	70	60	30	14	69	72.5
B1G6**	22	4.5 Thru	43.8	42	21	6.35	69	74.5
B1G7**	38.1	M5 depth 10	66.7	60	30	12.7	69	80.5
B1G8**	40	M4 depth 10	63	58	29	9	69	72.5
B2G3**	50	M5 depth 10	70	60	30	14	86	89.5
B2G5**	50	M4 depth 10	70	60	30	14	86	89.5
B2G7**	38.1	M4 depth 10	66.7	60	30	12.7	86	98.5
B2G8**	40	M4 depth 10	63	60	30	9	86	98.5
B2G9**	60	M5 depth 10	75	67	33.5	11	86	98.5

Note: \*\* represents an actual gear ratio

The GL-N model has an anti-dust cover. This cover is common to GL15N and GL20N.

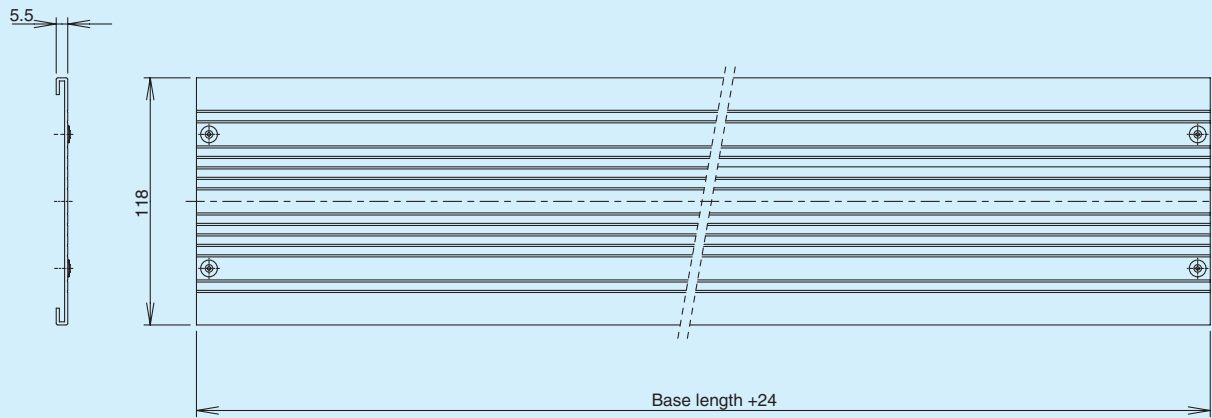
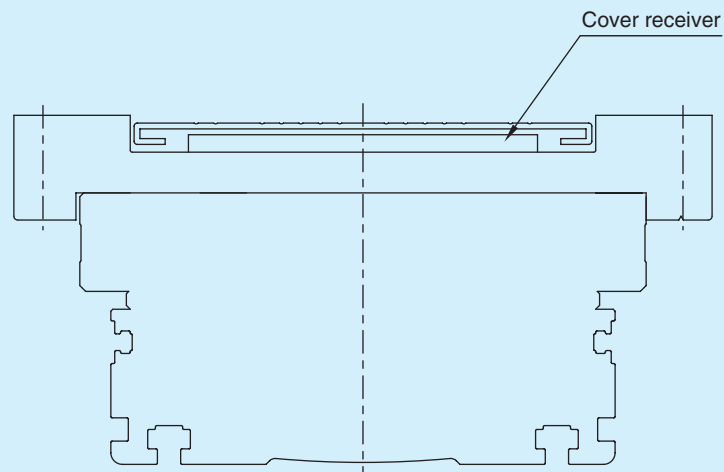

**Figure 10 Cover Outline View**

Note 1: Cover deflection increases long, If the base is as base length increases.

Note 2: If the GL-N model is used in any position other than horizontal, a part mounted on the table might touch the cover due to deflection caused by the cover.

Note 3: Cover is applied up to 1960mm base length.



**Figure 11 Section View of a Model with a Cover Receiver**

The GL-N model has an anti-dust bellows as well as an anti-dust cover.

## [GL15N Model, Ball Screw Driven]

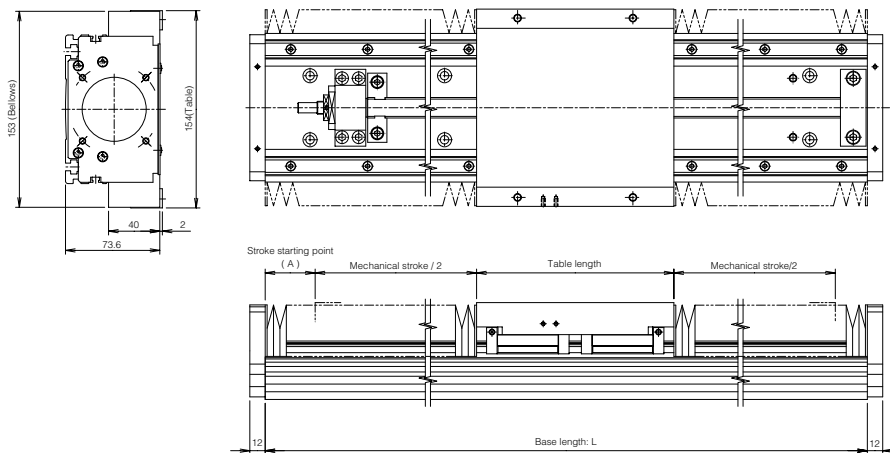

Unit: mm

Base length: L		340	460	580	700	820	1060	1240	1420	
Mechanical stroke	Table	S type	133	248	358	468	563	763	913	1058
		L type	119	234	340	440	535	735	885	1030
		L(QZ) type	110	225	335	440	535	735	885	1030
		L-QZ type	104	214	314	414	509	709	859	1004
Stroke starting point: A	Table	S type	53	53	53	53	65.5	85.5	100.5	118
		L type	39	39	43	53	65.5	85.5	100.5	118
		L(QZ) type	48	48	48	53	65.5	85.5	100.5	118
		L-QZ type	28	33	43	53	65.5	85.5	100.5	118

## [GL20N Model, Ball Screw Driven]

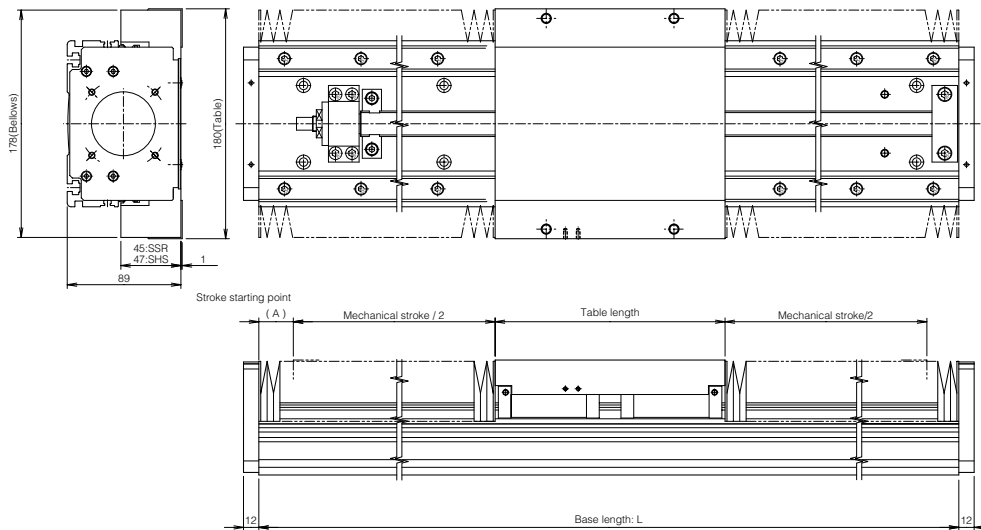

Unit: mm

Base length: L		460	580	700	820	1060	1240	1420	1600	1780	
Mechanical stroke	Table	S type	237	352	464	569	779	939	1094	1254	1409
		L type	227	339	444	549	759	919	1074	1234	1389
		L(QZ) type	220	336	444	549	759	919	1074	1234	1389
		L-QZ type	198	309	414	519	729	889	1044	1204	1359
Stroke starting point: A	Table	S type	37	37	38	45.5	60.5	70.5	83	93	105.5
		L type	27	30.5	38	45.5	60.5	70.5	83	93	105.5
		L(QZ) type	34	34	38	45.5	60.5	70.5	83	93	105.5
		L-QZ type	25.5	30.5	38	45.5	60.5	70.5	83	93	105.5

### [GL15N Model, Belt Driven]

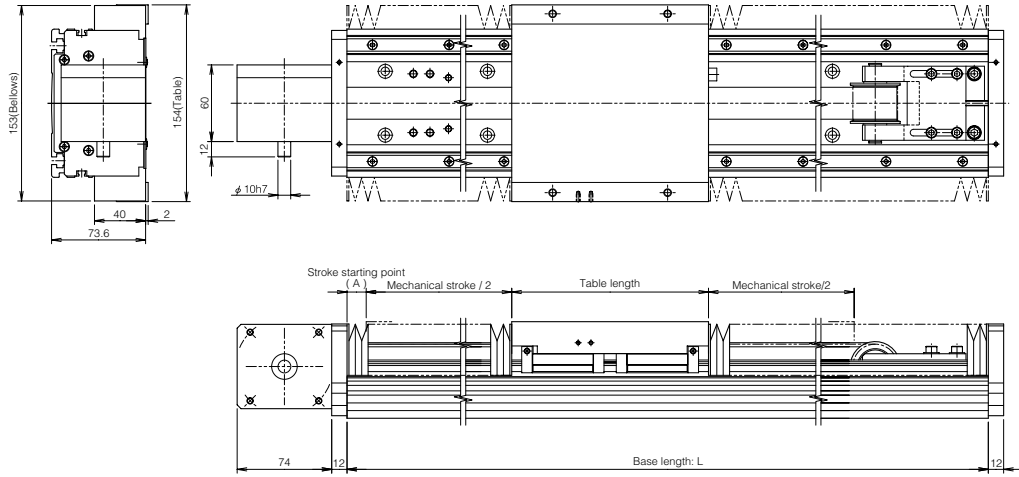

Unit: mm

Base length: L		340	460	580	700	820	1060	1240	1420	1600	1780	1960	
Mechanical stroke	Table	S type	78	186	291	396	501	698	833	973	1108	1243	1378
		L type	50	158	263	368	473	670	805	945	1080	1215	1350
		L-QZ type	24	132	237	342	447	644	779	919	1054	1189	1324
Stroke starting point: A		31	43	58	73	88	118	140.5	160.5	183	205.5	228	

### [GL20N Model, Belt Driven]

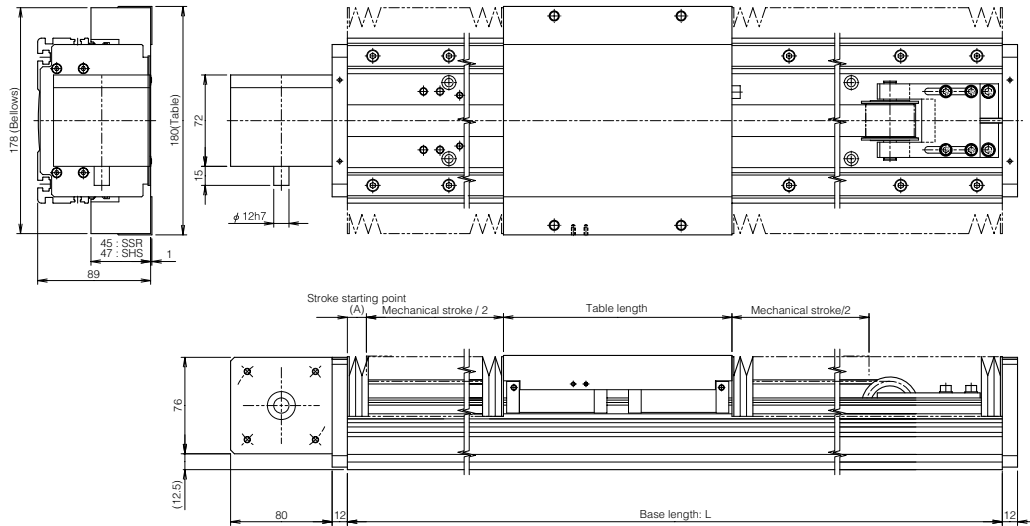

Unit: mm

Base length: L		460	580	700	820	1060	1240	1420	1600	1780	1960	2200	2320	2500	3000	
Mechanical stroke	Table	S type	159	267	374	482	697	849	989	1134	1274	1419	1609	1704	1844	2239
		L type	139	247	354	462	677	829	969	1114	1254	1399	1589	1684	1824	2219
		L-QZ type	109	217	324	432	647	799	939	1084	1224	1369	1559	1654	1794	2189
Stroke starting point: A		36	48	61	73	98	115.5	135.5	153	173	190.5	215.5	228	248	300.5	

The GL-N model allows various sensors to be set to the T groove at the side of the base.

[Control Number]

Type	Sensor model number	Quantity	Symbol	Manufacturer
Photo sensor	EE-SX671	3	A	OMRON
	EE-SX674	3	B	
Proximity sensor	TL-W3MC1	3	C1	
	TL-W3MC1	1	C2	
	TL-W3MC2	2	C3	
	TL-W3MB1	3	C4	
	TL-W3MB1	1	C4	
	TL-W3MB2	2		

[Dimensional Drawing]

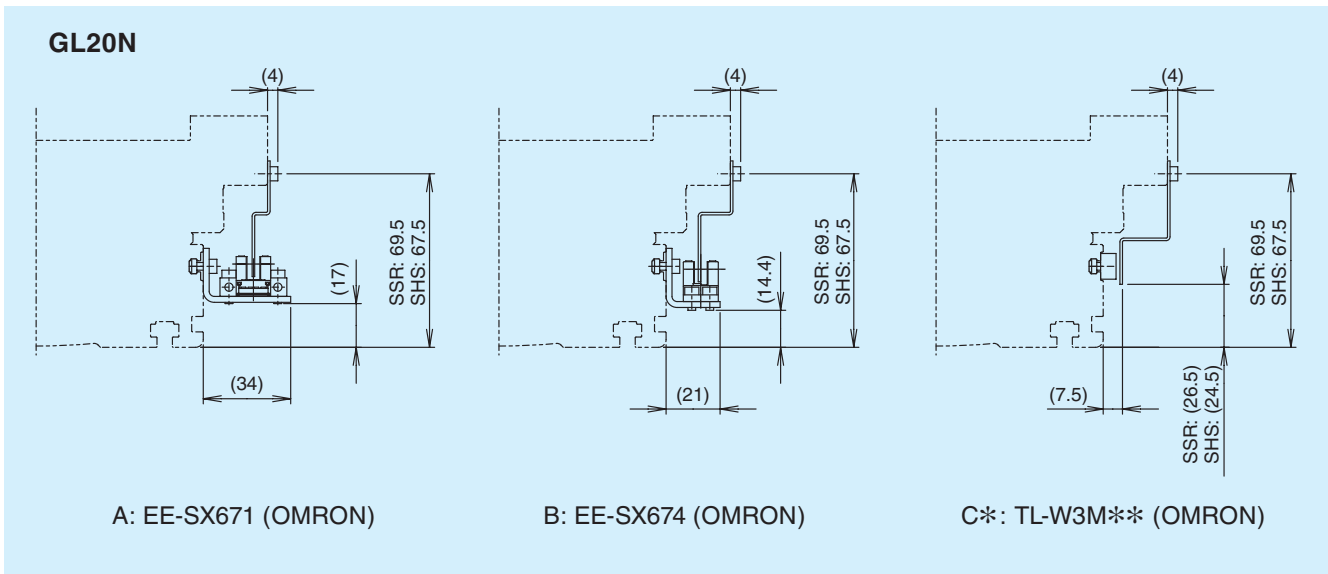
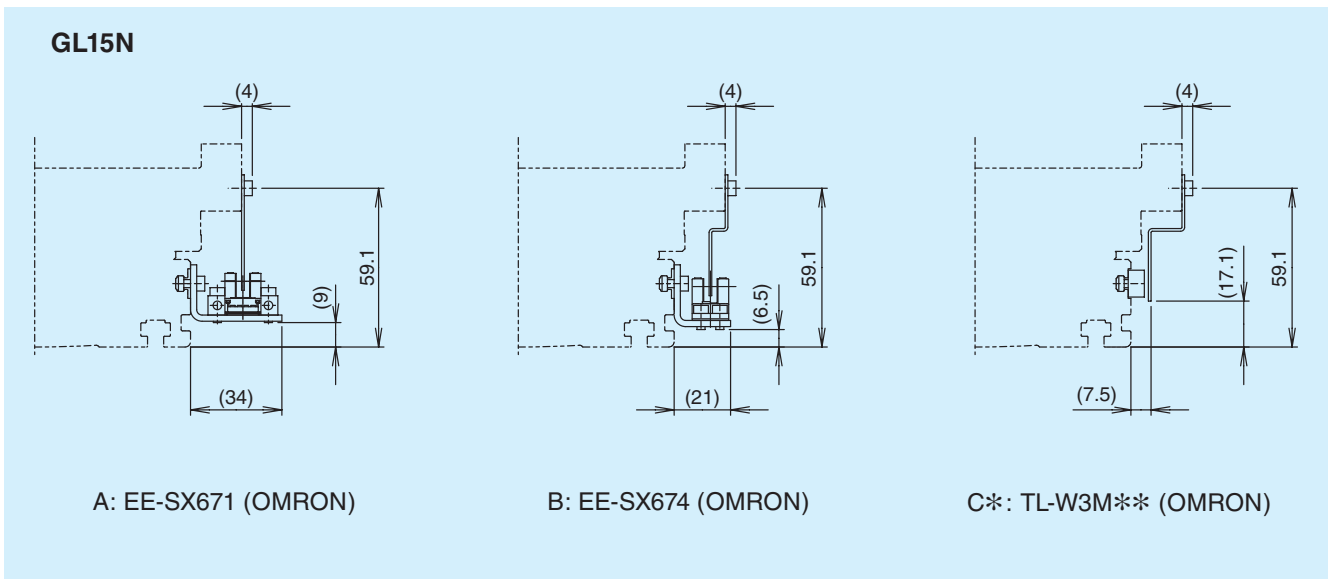

## Cable Carrier

The GL-N model enables various cable carriers to be set to the T groove at the side of the base.

### [Control Number]

Cable carrier model number	Manufacturer	Symbol	Max base length [mm]
TKP0180W40R28	TSUBAKIMOTO CHAIN CO.	A	1660
TKP0180W40R37		B	1960
TKP0180W40R50		C	
TKP0320W24R37		D	
TKP0320W24R50		E	

Cable carrier model number	Manufacturer	Symbol	Max base length [mm]
TKP0320W24R75	TSUBAKIMOTO CHAIN CO.	F	2440
TKP0320W50R37		G	2800
TKP0320W50R50		H	
TKP0320W50R75		I	

Note: For the selection of cable carriers, etc., refer to the catalogs of cable carriers.

### [Dimensional Drawing]

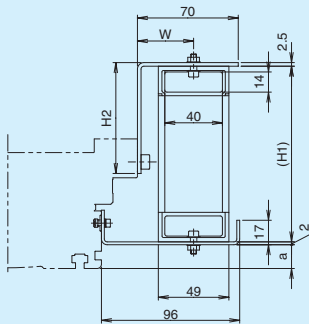

Unit: mm

Symbol	Cable carrier model number	H1	H2	Dimensions			
				W		a	
				GL15N	GL20N	GL15N	GL20N
A	TKP0180W40R28	(78)	33	45	39	8.6	16.5
B	TKP0180W40R37	(96)	51				
C	TKP0180W40R50	(122)	77				

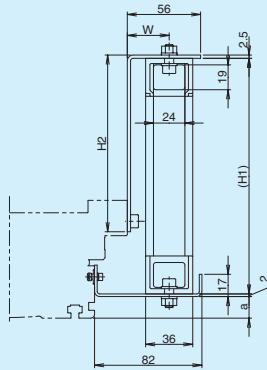

Unit: mm

Symbol	Cable carrier model number	H1	H2	Dimensions			
				W		a	
				GL15N	GL20N	GL15N	GL20N
D	TKP0320W24R37	(104)	59	38	32	8.6	16.5
E	TKP0320W24R50	(130)	85				
F	TKP0320W24R75	(180)	135				

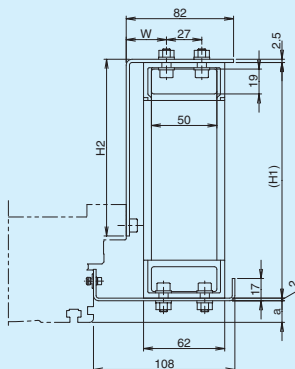

Unit: mm

Symbol	Cable carrier model number	H1	H2	Dimensions			
				W		a	
				GL15N	GL20N	GL15N	GL20N
G	TKP0320W50R37	(104)	59	36.75	30.75	8.6	16.5
H	TKP0320W50R50	(130)	85				
I	TKP0320W50R75	(180)	135				

## Base-Mounting Fasteners

Base-mounting plate fasteners are available if they are necessary. Please contact THK for further details.

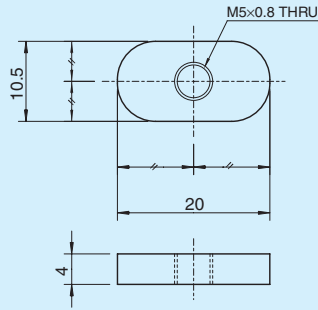

Standard base length (mm)	340	460	580	700	820	1060	1240	1420	1600	1780	1960	2200	2320	2500	3000
Quantity	4	4	6	6	8	10	10	12	14	14	16	16	18	18	20

## Appendix

### Service Life Time and Static Safety factor

The GL-N model consists of LM Guides, a ball screw, and support units. The life and safety factor of each component can be calculated from the basic dynamic load rating and the basic static load rating. For more information on these, refer to each item (LM Guides, ball screws, and support units) in the general catalog.

The nominal life of the LM Guides and ball screw can be calculated using the technical calculation software available from the THK Technical Support Site or contained in the CD-ROM catalog. In calculating the nominal life, see the data in the following table.

Note: Please note that the calculation of life is theoretical. In actual use, the life varies depending on the service conditions such as the usage environment, the lubricating condition, the accuracy or rigidity of the area where the LM actuator is installed, and so forth.

### [LM Guide]

Actuator model number	Table type	LM Guide model number	Thrust position		Rail span W (mm)	Block span L1 (mm)	Movable section					Slider height H (mm)
			B1 (mm)	B2 (mm)			Mass m1 (kg)	Gravity center				
				B1 (mm)	B2 (mm)	W (mm)	L1 (mm)	m1 (kg)	G1 (mm)	G2 (mm)	G3 (mm)	H (mm)
Ball screw type	GL15N-***-SV-B	S	SSR15XVUU-Y	45	-5.4	90	82	1.7	45	41	30	43
	GL15N-***-SW-B	L	SSR15XWUU-Y		-5.4		74	2.2		37	30	43
	GL15N-***-SWQ-B	L-QZ	SSR15XWQZUU-Y		-5.4		94	2.4		47	30	43
	GL15N-***-HV-B	L	SHS15VUU		-5.4		74	2.2		37	30	43
	GL15N-***-HVQ-B	L-QZ	SHS15VQZUU		-5.4		94	2.4		47	30	43
	GL20N-***-SV-B	S	SSR20XVUU	51	-2	102	108	2.7	51	54	34.6	48
	GL20N-***-SW-B	L	SSR20XWUU		-2		108	3.2		54	34.6	48
	GL20N-***-SWQ-B	L-QZ	SSR20XWQZUU		-2		110	3.4		55	34.6	48
	GL20N-***-HV-B	L	SHS20VUU		-4		96	3.6		48	36.6	50
	GL20N-***-HVQ-B	L-QZ	SHS20VQZUU		-4		110	3.8		55	36.6	50
Belt drive type	GL15N-***-SV-E	S	SSR15XVUU-Y	45	-26	90	82	1.2	45	41	30	43
	GL15N-***-SW-E	L	SSR15XWUU-Y		-26		74	1.7		37	30	43
	GL15N-***-SWQ-E	L-QZ	SSR15XWQZUU-Y		-26		94	1.8		47	30	43
	GL15N-***-HV-E	L	SHS15VUU		-26		74	1.7		37	30	43
	GL15N-***-HVQ-E	L-QZ	SHS15VQZUU		-26		94	1.8		47	30	43
	GL20N-***-SV-E	S	SSR20XVUU	51	-27	102	108	2.1	51	54	34.6	48
	GL20N-***-SW-E	L	SSR20XWUU		-27		108	2.6		54	34.6	48
	GL20N-***-SWQ-E	L-QZ	SSR20XWQZUU		-27		110	2.8		55	34.6	48
	GL20N-***-HV-E	L	SHS20VUU		-29		96	3.0		48	36.6	50
	GL20N-***-HVQ-E	L-QZ	SHS20VQZUU		-29		110	3.2		55	36.6	50

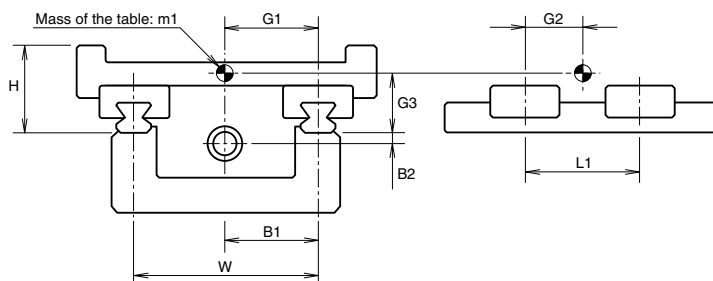

## [Ball Screw]

Actuator model number			Mechanical stopper-to-mechanical stopper stroke (mm)			Ball screw			
Nominal model number	Base length* (mm)	Ball screw	S type	L type	L-QZ type	Mounting method	Category	Nut model number	Mounting distance
			SV	SW, HV	SWQ, HVQ				MAX (mm)
GL15N	034	B05	136	122	114	Fixed-support	Rolled-without pre-load	BTK1605-2.6ZZ	186
	142		1216	1202	1194				1266
GL15N	034	B10	136	122	114	Fixed-support	Rolled-without pre-load	BLK1510-5.6ZZ	179
	142		1216	1202	1194				1259
GL15N	034	B16	136	122	114	Fixed-support	Rolled-without pre-load	BLK1616-3.6	176
	142		1216	1202	1194				1256
GL15N	034	B20	136	122	114	Fixed-support	Rolled-without pre-load	WTF1520-3ZZ	179
	142		1216	1202	1194				1259
GL15N	034	B30	136	122	114	Fixed-support	Rolled-without pre-load	WTF1530-2ZZ	179
	142		1216	1202	1194				1259
GL20N	046	B05	238	228	220	Fixed-support	Rolled-without pre-load	BTK2005-2.6ZZ	299
	178		1558	1548	1540				1619
GL20N	046	B10	238	228	220	Fixed-support	Rolled-without pre-load	BLK1510-5.6ZZ	299
	142		1198	1188	1180				1259
GL20N	046	B20	238	228	220	Fixed-support	Rolled-without pre-load	BLK2020-3.6ZZ	297
	178		1558	1548	1540				1617
GL20N	046	B40	238	228	220	Fixed-support	Rolled-without pre-load	WTF2040-2ZZ	297
	178		1558	1548	1540				1617

\* The base length shows the minimum and maximum lengths. Example: 034 for a base length of 340mm and 142 for a base length of 1420mm  
 Note: Sliding resistance listed is total for all four LM Guide blocks.

LM Guide model number symbol	Movable section mass (kg)	Sliding resistance (N)
GL15N-***-SV	1.7	16.2
GL15N-***-SW	2.2	16.6
GL15N-***-SWQ	2.4	26.6
GL15N-***-HV	2.2	17.2
GL15N-***-HVQ	2.4	33.2
GL20N-***-SV	2.7	21.0
GL20N-***-SW	3.2	21.4
GL20N-***-SWQ	3.4	33.4
GL20N-***-HV	3.6	20.6
GL20N-***-HVQ	3.8	36.6

## [Support Unit]

Nominal model number	Support unit fixed side			Support unit support side	
	Model number	Angular ball bearing		Deep-groove ball bearing	
		Bearing model number		Model number	Bearing model number
GL15N	GK10S	7000HTDFGMP5 (Direct-mounting specification)		GF10	608ZZ
		7000HTDBGMP5 (Wrap-around specification)			
GL20N	GK12S	7001HTDFGMP5 (Direct-mounting specification)		GF12	6000ZZ
		7001HTDBGMP5 (Wrap-around specification)			

## Motor Selection

When selecting a motor that is installed on the GL-N model, refer to the following data. For details of the motor selection method and motor specifications, contact the motor manufacturer.

## [Ball Screw Specifications]

Actuator model number			Ball screw shaft				
Nominal model number	Base length*1 (mm)	Ball screw	Model number	Outer diameter (mm)	Lead (mm)	Length*2 (mm)	Shaft-end outer diameter (mm)
GL15N	034	B05	BTK1605-2.6ZZ	16	5	311	ø 8h7
	142					1391	
GL15N	034	B10	BLK1510-5.6ZZ	15	10	311	ø 8h7
	142					1391	
GL15N	034	B16	BLK1616-3.6	16	16	311	ø 8h7
	142					1391	
GL15N	034	B20	WTF1520-3ZZ	15	20	311	ø 8h7
	142					1391	
GL15N	034	B30	WTF1530-2ZZ	15	30	311	ø 8h7
	142					1391	
GL20N	046	B05	BTK2005-2.6ZZ	20	5	427	ø 10h7
	178					1747	
GL20N	046	B10	BLK1510-5.6ZZ	15	10	427	ø 10h7
	142					1387	
GL20N	046	B20	BLK2020-3.6ZZ	20	20	427	ø 10h7
	178					1747	
GL20N	046	B40	WTF2040-2ZZ	20	40	427	ø 10h7
	178					1747	

LM Guide model number symbol	Movable section mass (kg)	Sliding resistance (N)
GL15N-***-SV	1.7	16.2
GL15N-***-SW	2.2	16.6
GL15N-***-SWQ	2.4	26.6
GL15N-***-HV	2.2	17.2
GL15N-***-HVQ	2.4	33.2
GL20N-***-SV	2.7	21.0
GL20N-***-SW	3.2	21.4
GL20N-***-SWQ	3.4	33.4
GL20N-***-HV	3.6	20.6
GL20N-***-HVQ	3.8	36.6

Timing pulley	
Nominal model number	Moment of inertia (kg-cm <sup>2</sup> )
GL15N	0.12
GL20N	0.12

Allowable input torque*3	
Nominal model number	(N-m)
GL15N	2.8
GL20N	5.3

\*1 The base length shows the minimum and maximum lengths.

Example: 034 for a base length of 340mm and 142 for a base length of 1420mm

\*2 The length of a ball screw shaft is the length available for the direct-mounting specification. For the wrap-around specification, the length of the ball screw shaft is 74mm longer for the GL15N model and 78mm longer for the GL20N model.

\*3 The allowable input torque is the value for the direct-mounting specification. For the wrap-around specification, contact THK.

Note: Sliding resistance listed is total for all four LM Guide blocks.

## [Belt Specifications]

Actuator model number		Belt		Timing pulley			
Nominal model number	Timing belt	Model number	Mass* (kg)	Model number	Diameter (PCD) (mm)	Table moving distance/one turn of pulley	Moment of inertia (total of two pulleys) (kg-cm <sup>2</sup> )
GL15N	EH	025-MA5	0.38	22-MA5-025	35.01	110 mm	0.289
GL20N	EH	025-MA5	0.58	24-MA5-025	38.20	120 mm	0.447

Reducer		
Reduction ratio	Rated output (W)	Moment of inertia (kg-cm <sup>2</sup> )
1/3	100	0.058
1/3	200	0.135
1/5	100	0.04
1/5	200	0.118
1/9	100	0.035

Allowable input torque	
Nominal model number	(N-m)
GL15N	4.8
GL20N	8.1

LM Guide model number symbol	Movable section mass (kg)	Sliding resistance (N)
GL15N-***-SV	1.2	16.2
GL15N-***-SW	1.7	16.6
GL15N-***-SWQ	1.8	26.6
GL15N-***-HV	1.7	17.2
GL15N-***-HVQ	1.8	33.2
GL20N-***-SV	2.1	21.0
GL20N-***-SW	2.6	21.4
GL20N-***-SWQ	2.8	33.4
GL20N-***-HV	3.0	20.6
GL20N-***-HVQ	3.2	36.6

\* The belt mass is the mass for the maximum belt length.

Note: Sliding resistance listed is total for all four LM Guide blocks.

## Precautions on Use

### Handling

- (1) Do not disassemble this product. Doing so may allow foreign matter or objects to enter the product or cause deterioration of its precision.
- (2) Do not drop or strike this product. Doing so may damage the product. If this product is under a shock, its functions may be damaged even though it looks normal in appearance.

### Lubricant

- (1) Wipe out anti-rust oil completely, then apply lubricator.
- (2) Do not mix lubricants with different properties when applying lubricants.
- (3) Contact us in advance before using this product in places subject to constant vibration, or in special environments such as clean room, vacuum, low temperatures or high temperatures, regular lubricants may not be used in such environments. Contact us to purchase the dedicated low-dust-raising grease, when using this product in a clean room.
- (4) Contact us in advance when using the special lubricant.
- (5) Lubrication is essential to ensure the best performance of this product. When no lubricant is applied, it sometimes causes not only the roller to be wear, but also the product life is shortened.
- (6) Usually, grease must be applied to this product every 100 kilometers under normal operating conditions. The interval for grease application must be determined upon initial inspection.

### Notes on Use

- (1) If a foreign object or foreign matter enters this product, the ball circulation components may be damaged or its functions may deteriorate. Prevent foreign matters or objects such as trash and chips.
- (2) Contact us in advance when using this product is used in environments where coolants enter the interior of the product, because some types of coolant may lower the performance of the product's functions.
- (3) This product must be used within a temperature range from +5°C to 40°C. In addition, humidity must be 80% or less and no dew condensation must occur. Contact us in advance if planning to use this product in a different range of temperature or humidity.
- (4) Contact us in advance when using this product in a place subject to constant vibration or in special environments such as clean room, vacuum, low temperatures or high temperatures.

### Storage

This product must be leveled in our package or a shipment package during stock. Avoid any place with low temperature, high temperature or high humidity. If necessary, CAD data (DXF format) for this product may be downloaded from the website of our technical support center.

- "LM GUIDE" and " are the registered trademarks of THK CO., LTD.
- There may be differences between products appearing in photographs and the actual product.
- The appearance, specifications, and other information are subject to change without prior notice to improve reliability, function, etc. When deciding to adopt the product, contact us beforehand.
- We have exercised great care in preparing this catalog, but it is still possible that are misspellings, omissions of letters, etc. THK assumes no responsibility or liability for damage resulting from such errors possibly contained herein.
- We employ the basic policy of observing the Foreign Exchange and Foreign Trade Control Law of Japan with regard to the export of our products/technologies or sales for export. For export of our products as discrete components, consult THK beforehand.

All rights reserved

# THK CO., LTD.

HEAD OFFICE 3-11-6, NISHI-GOTANDA, SHINAGAWA-KU, TOKYO 141-8503 JAPAN  
INTERNATIONAL SALES DEPARTMENT PHONE:+81-3-5434-0351 FAX:+81-3-5434-0353  
Global site : <http://www.thk.com/>

#### NORTH AMERICA

THK America, Inc.  
● HEADQUARTERS  
Phone:+1-847-310-1111 Fax:+1-847-310-1271  
● CHICAGO OFFICE  
Phone:+1-847-310-1111 Fax:+1-847-310-1182  
● NORTH EAST OFFICE  
Phone:+1-845-369-4035 Fax:+1-845-369-4909  
● ATLANTA OFFICE  
Phone:+1-770-840-7990 Fax:+1-770-840-7897  
● LOS ANGELES OFFICE  
Phone:+1-949-955-3145 Fax:+1-949-955-3149  
● SAN FRANCISCO OFFICE  
Phone:+1-925-455-8948 Fax:+1-925-455-8965  
● DETROIT OFFICE  
Phone:+1-248-858-9330 Fax:+1-248-858-9455  
● TORONTO OFFICE  
Phone:+1-905-820-7800 Fax:+1-905-820-7811

#### SOUTH AMERICA

THK Brasil LTDA  
Phone:+55-11-3767-0100 Fax:+55-11-3767-0101

#### EUROPE

THK GmbH  
● EUROPEAN HEADQUARTERS  
Phone:+49-2102-7425-555 Fax:+49-2102-7425-556  
● DÜSSELDORF OFFICE  
Phone:+49-2102-7425-0 Fax:+49-2102-7425-299

#### FRANKFURT OFFICE

Phone:+49-2102-7425-650 Fax:+49-2102-7425-699

#### STUTTGART OFFICE

Phone:+49-7150-9199-0 Fax:+49-7150-9199-888

#### MÜNCHEN OFFICE

Phone:+49-8937-0616-0 Fax:+49-8937-0616-26

#### U.K. OFFICE

Phone:+44-1908-30-3050 Fax:+44-1908-30-3070

#### ITALY MILANO OFFICE

Phone:+39-039-284-2079 Fax:+39-039-284-2527

#### ITALY BOLOGNA OFFICE

Phone:+39-051-641-2211 Fax:+39-051-641-2230

#### SWEDEN OFFICE

Phone:+46-8-445-7630 Fax:+46-8-445-7639

#### AUSTRIA OFFICE

Phone:+43-7229-51400 Fax:+43-7229-51400-79

#### SPAIN OFFICE

Phone:+34-93-652-5740 Fax:+34-93-652-5746

#### TURKEY OFFICE

Phone:+90-216-362-4050 Fax:+90-216-569-7150

#### PRAGUE OFFICE

Phone:+420-2-41025-100 Fax:+420-2-41025-199

#### MOSCOW OFFICE

Phone:+7-495-649-80-47 Fax:+7-495-649-80-44

#### THK Europe B.V.

● EINDHOVEN OFFICE  
Phone:+31-040-290-9500 Fax:+31-040-290-9599

#### THK France S.A.S.

Phone:+33-4-3749-1400 Fax:+33-4-3749-1401

#### CHINA

THK (CHINA) CO., LTD.

#### HEADQUARTERS

Phone:+86-411-8733-7111 Fax:+86-411-8733-7000

#### SHANGHAI OFFICE

Phone:+86-21-6219-3000 Fax:+86-21-6219-9890

#### BEIJING OFFICE

Phone:+86-10-8441-7277 Fax:+86-10-6590-3557

#### CHENGDU OFFICE

Phone:+86-28-8526-8025 Fax:+86-28-8525-6357

#### GUANGZHOU OFFICE

Phone:+86-20-8523-8418 Fax:+86-20-3801-0456

#### SHENZHEN OFFICE

Phone:+86-755-2642-9587 Fax:+86-755-2642-9604

#### THK (SHANGHAI) CO., LTD.

Phone:+86-21-6275-5280 Fax:+86-21-6219-9890

#### TAIWAN

THK TAIWAN CO., LTD.

#### TAIPEI HEAD OFFICE

Phone:+886-2-2888-3818 Fax:+886-2-2888-3819

#### TAICHUNG OFFICE

Phone:+886-4-2359-1505 Fax:+886-4-2359-1506

#### TAINAN OFFICE

Phone:+886-6-289-7668 Fax:+886-6-289-7669

#### KOREA

SEOUL REPRESENTATIVE OFFICE

Phone:+82-2-3468-4351 Fax:+82-2-3468-4353

#### SINGAPORE

THK LM SYSTEM Pte. Ltd.

Phone:+65-6884-5500 Fax:+65-6884-5550

#### INDIA

BANGALORE REPRESENTATIVE OFFICE

Phone:+91-80-2330-1524 Fax:+91-80-2330-1524