

## Cylinders Series 61

Single, double-acting, magnetic (DIN/ISO 6431)  
 Bore:  $\varnothing$  32, 40, 50, 63, 80, 100, 125 cushioned  
 [1 1/4", 1 9/16", 2", 2 1/2",  
 3 1/8", 4", 5" inch approximations]



The Series 61 cylinders with diameters 32, 40, 50, 63, 80, 100 and 125 have been designed to comply with the dimensions laid down in the DIN/ISO 6431 standards. The extruded aluminum tube with improved aesthetics, has two grooves (on three sides) where the proximity switch Mod. CST can be directly mounted. This enables the same cylinder dimensions to be retained.

Four tie-rods located inside of the tube make the mounting of the end-blocks extremely secure. This cylinder series is equipped with adjustable end-stroke cushioning. Moreover, these cylinders are also equipped with a mechanical cushioning in order to reduce the impact of the piston as it reaches the end of the stroke (only until  $\varnothing$ 100). The cylinder series can also accommodate stroke lengths up to 1000 mm for bore sizes shown in the table.



- ▶ DIN/ISO 6431/VDMA 24562
- ▶ High durability
- ▶ Clean design

### GENERAL DATA

Type of construction	with tie-rods
Operation	double-acting, single-acting, other parts see coding
Materials	aluminum end-blocks, other parts see coding
Type of mounting	with tie-rods, front flange, rear flange, feet front and rear trunnion, swivel combination
Stroke	10 – 2500mm
Bore	$\varnothing$ 32, 40, 50, 63, 80, 100, 125
Ports	32 = 1/8, 40/50 = 1/4, 63/80 = 3/8, 100/125 = 1/2
Assembly position	any position
Operating temperature	0 – 80°C (with dry air –20°C), 32°F – 175°F (dry air – 4°F)
Special designs	for applications in damp, dusty or aggressive environments

**PNEUMATIC SPECIFICATIONS**

Operating pressure	1 – 10 bar [Min. 1 bar (14.5psi); Max. 10 bar (145 psi)]
Speed	10 – 1000 mm/sec (No load) [Min. 10 mm/sec(No load); Max ≤ 1000mm/sec (No load)]
Fluid	clean air, lubrication*

\*if lubricated air is used, it is recommended to use oil ISOVG32. Once applied the lubrication should never be interrupted.

**CYLINDER CODING**

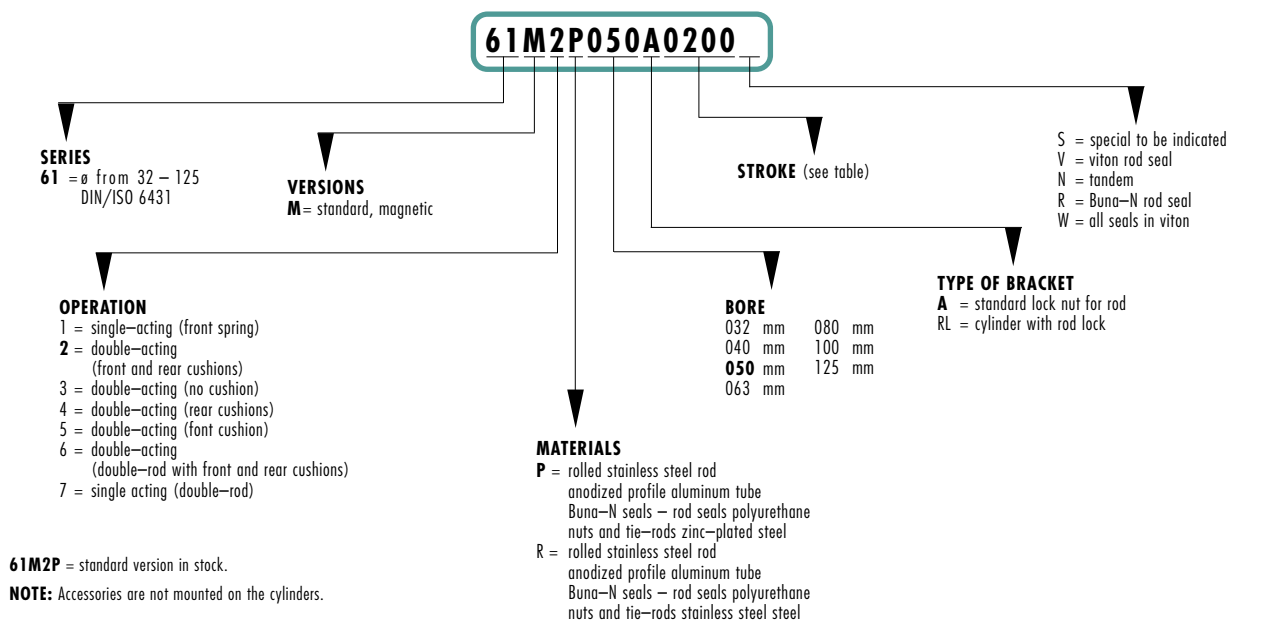

**CHARACTERISTICS OF SINGLE-ACTING CYLINDERS SERIES 60-61**

Force in N x 0.2245 = lbf

ømm	min-max stroke	Extend N at 6 bar	Force of spring at rest N (stroke 75 mm)	Force of compressed spring N
32	10 – 75	425	31	57
40	10 – 75	664	35	57
50	10 – 75	1037	60	115
63	10 – 75	1650	60	115
80	10 – 75	2660	84	133
100	10 – 75	4154	84	133

**NOTE :** the Series 60-61 single-acting cylinders' dimensions for L1 and L2 are to be increased by 25 mm.

TABLE SHOWING AIR CONSUMPTION OF SERIES 61

ø Cyl. in mm (inch)	ø Rod in mm	Working area in cm <sup>2</sup> .	Operating pressure in bar 1 bar = 14.5 psi										
			1	2	3	4	5	6	7	8	9	10	
			Air consumption in NL for each 10 mm of stroke										
32 (1 1/4")	12	Extend side	8.03	0.016	0.024	0.032	0.040	0.048	0.056	0.064	0.072	0.080	0.088
		Retract side	6.9	0.014	0.021	0.028	0.035	0.042	0.048	0.055	0.062	0.069	0.076
40 (1 9/16")	16	Extend side	12.56	0.025	0.038	0.050	0.063	0.075	0.088	0.100	0.113	0.126	0.138
		Retract side	10.56	0.021	0.032	0.042	0.053	0.063	0.074	0.085	0.095	0.106	0.116
50 (2")	20	Extend side	19.6	0.039	0.059	0.079	0.098	0.118	0.137	0.157	0.177	0.196	0.216
		Retract side	16.48	0.033	0.050	0.066	0.083	0.099	0.115	0.132	0.148	0.165	0.182
63 (2 1/2")	20	Extend side	31.15	0.062	0.094	0.125	0.156	0.187	0.218	0.249	0.280	0.312	0.343
		Retract side	28	0.056	0.084	0.112	0.140	0.168	0.196	0.224	0.252	0.280	0.308
80 (3 1/8")	25	Extend side	50.25	0.101	0.151	0.201	0.251	0.302	0.352	0.402	0.452	0.503	0.553
		Retract side	45.35	0.091	0.136	0.181	0.227	0.272	0.317	0.363	0.408	0.454	0.499
100 (4")	25	Extend side	78.5	0.157	0.235	0.314	0.392	0.471	0.550	0.628	0.707	0.785	0.864
		Retract side	73.6	0.147	0.221	0.295	0.368	0.441	0.515	0.589	0.663	0.736	0.810
125 (5")	32	Extend side	122.65	0.245	0.368	0.491	0.614	0.736	0.859	0.982	1.104	1.227	1.350
		Retract side	115.6	0.229	0.344	0.459	0.573	0.688	0.803	0.917	1.032	1.147	1.261

THE VALUES SHOWN IN THE TABLE WERE OBTAINED USING THE FOLLOWING FORMULA:  $Q_s = \frac{D^2 \cdot \pi \cdot (P + 1)}{4 \cdot 1000} \cdot H$   $Q_n = (Q_s + Q_t) \cdot n$   $Q_t = \frac{(D^2 - d^2) \cdot \pi \cdot (P + 1)}{4 \cdot 1000} \cdot H$

$Q_s$  = consumption on extend side     $Q_t$  = consumption on retract side     $Q_n$  = consumption of cylinder     $n$  = number of cycles per minute  
 $D$  = diameter on extend side in cm.     $d$  = diameter of rod in cm     $H$  = cylinder stroke in cm     $P$  = operating pressure in bar

TABLE SHOWING THE OUTPUT FORCE OF SERIES 61

ø Cyl. in mm (inch)	ø Rod in mm	Working area in cm <sup>2</sup> .	Operating pressure in bar 1 bar = 14.5 psi										
			1	2	3	4	5	6	7	8	9	10	
			Output force in N (efficiency factor 0,9)					Force in N x 0.2245 lbf					
32 (1 1/4")	12	Extend side	8.03	70	140	210	283	354	425	494	595	635	706
		Retract side	6.9	60	120	180	243	305	365	426	487	548	608
40 (1 9/16")	16	Extend side	12.56	110	220	330	443	554	664	775	886	998	1108
		Retract side	10.56	93	186	280	375	465	559	652	745	838	931
50 (2")	20	Extend side	19.6	173	346	518	692	865	1037	1210	1382	1556	1729
		Retract side	16.48	145	290	436	582	727	872	1017	1163	1308	1454
63 (2 1/2")	20	Extend side	31.15	275	550	824	1098	1373	1650	1923	2198	2472	2747
		Retract side	28	247	494	740	988	1235	1480	1729	1976	2222	2470
80 (3 1/8")	25	Extend side	50.25	443	886	1330	1772	2216	2660	3100	3545	3990	4432
		Retract side	45.35	400	800	1200	1600	2000	2400	2800	3200	3600	4000
100 (4")	25	Extend side	78.5	692	1385	2077	2770	3460	4154	4847	5540	6320	6923
		Retract side	73.6	650	1300	1948	2608	3245	3895	4544	5193	5842	6492
125 (5")	32	Extend side	122.65	1090	2180	3270	4360	5450	6540	7631	8721	9811	10901
		Retract side	115.6	1019	2037	3056	4075	5093	6112	7130	8149	9168	10186

THE VALUES SHOWN IN THE TABLE WERE OBTAINED USING THE FOLLOWING FORMULA:  $S_s = \frac{D^2 \cdot \pi}{4} \cdot P \cdot \eta$   $S_t = \frac{(D^2 - d^2) \cdot \pi}{4} \cdot P \cdot \eta$

$S_s$  = output force on extend side     $P$  = operating pressure in bar     $d$  = diameter of rod in cm  
 $S_t$  = output force on retract side     $D$  = diameter on extend side in cm     $\eta$  = efficiency factor

**Cylinders Series 61**

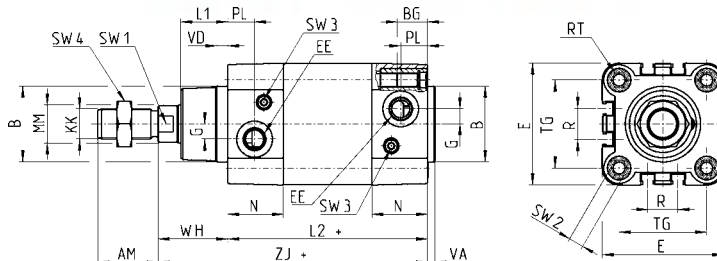

+ add the stroke

DIMENSIONS																							
ø	MM	KK	B <sup>d11</sup>	PL	L1	AM	VA	EE	WH	L2	ZJ	VD	N	BG	RT	G	TG	R	E	SW1	SW2	SW3	Cushion stroke
32	12	M10x1,25	30	14	18	22	4	G1/8	26	94	120	5	26	16	M6	5	32,5	13	46	10	6	2	19
40	16	M12x1,25	35	15	21	24	4	G1/4	30	105	135	5	29	16	M6	5	38	13,5	55	13	6	2	22
50	20	M16x1,5	40	15	25	32	4	G1/4	37	106	143	6	29,5	16	M8	8	46,5	16	64,5	17	8	3	22
63	20	M16x1,5	45	21	26	32	4	G3/8	37	121	158	6	36,5	16	M8	8	56,5	28	75	17	8	3	22
80	25	M20x1,5	45	21	30	40	4	G3/8	46	128	174	7	36	19	M10	8	72	30	93	22	10	5	25
100	25	M20x1,5	55	23	35	40	4	G1/2	51	138	189	7	38,5	19,5	M10	8	89	40	110	22	10	5	25
125	32	M27x2	60	23,5	42	54	6	G1/2	65	160	225	8	43	23	M12	10,5	110	50	135	27	12	4	43

N.B. : the single-acting cylinders' sizes L1 nd L2 are increased by 25 mm.

**Cylinders Series 61**

Double-rod

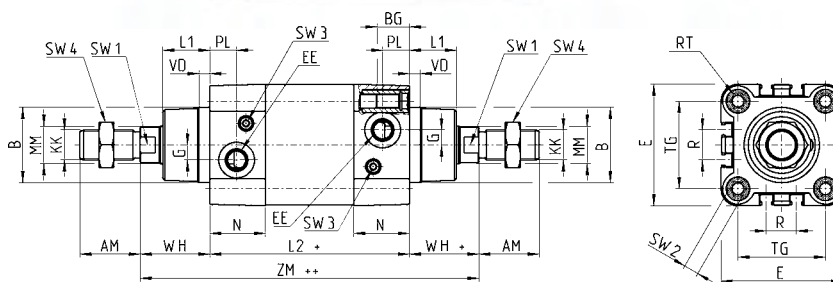

+ add the stroke  
++ add the stroke two times

DIMENSIONS																						
ø	MM	KK	B <sup>d11</sup>	PL	L1	AM	EE	WH	L2	ZM	VD	N	RT	BG	G	TG	R	E	SW1	SW2	SW3	Cushion stroke
32	12	M10x1,25	30	14	18	22	G1/8	26	94	146	5	26	M6	16	5	32,5	13	46	10	6	2	19
40	16	M12x1,25	35	15	21	24	G1/4	30	105	165	5	29	M6	16	5	38	13,5	55	13	6	2	22
50	20	M16x1,5	40	15	25	32	G1/4	37	106	180	6	29,5	M8	16	8	46,5	16	64,5	17	8	3	22
63	20	M16x1,5	45	21	26	32	G3/8	37	121	195	6	36,5	M8	16	8	56,5	28	75	17	8	3	22
80	25	M20x1,5	45	21	30	40	G3/8	46	128	220	7	36	M10	19	8	72	30	93	22	10	5	25
100	25	M20x1,5	55	23	35	40	G1/2	51	138	240	7	38,5	M10	19,5	8	89	40	110	22	10	5	25
125	32	M27x2	60	23,5	42	54	G1/2	65	160	290	8	43	M12	23	10,5	110	50	135	27	12	4	43

N.B. : the single-acting cylinders' sizes L1 nd L2 are increased by 25 mm.

Cylinders Series 61 tandem

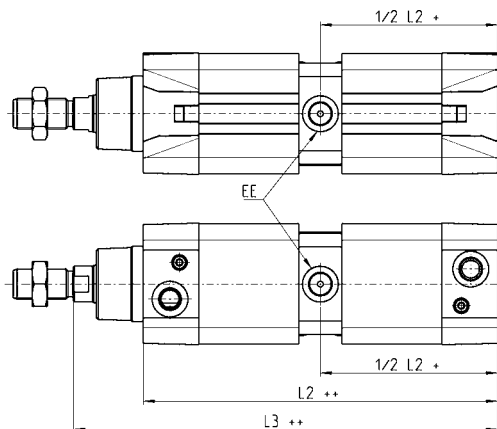

DIMENSIONS

∅	EE	L2	L3
32	G1/8	171,5	197,5
40	G1/4	191,5	221,5
50	G1/4	188	225
63	G3/8	204	230
80	G3/8	225,5	271,5
100	G1/2	231	282
125	G1/2	264	329

Cylinders Series 61 with rod lock

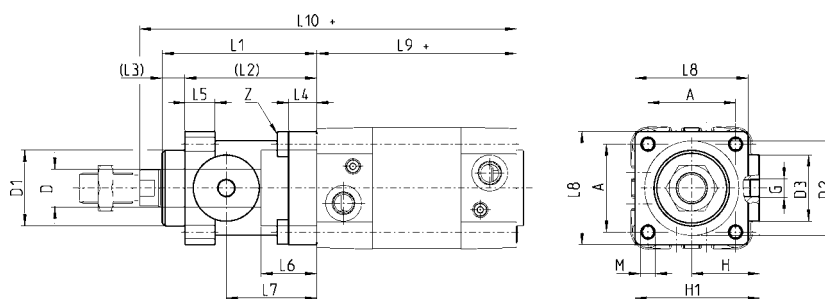

DIMENSIONS

∅	L1	L2	L3	L4	L5	L6	L7	L8	L9	L10	∅D	∅D1 <sup>d11</sup>	∅D2	∅D3 <sup>18</sup>	A <sup>0.15</sup>	G	H	H1	M	Z
32	58	48	10	8	13	20,5	34	45	94	160	12	30,5	35	25	32,5	M5	25,5	46,5	M6	M6x20
40	65	55	10	8	13	22,5	38	50	105	178	16	35	40	28	38	G1/8	30	53	M6	M6x20
50	82	70	12	15	16	29,5	48	60	106	200	20	40	50	35	46,5	G1/8	36	64	M8	M6x20
63	82	70	12	15	16	29,5	49,5	70	121	215	20	45	60	38	56,5	G1/8	40	75	M8	M8x30
80	110	90	20	18	20	35	61	90	128	254	25	45	80	48	72	G1/8	50	95	M10	M10x35
100	115	100	15	1	20	39	69	105	138	269	25	55	100	58	89	G1/8	58	110,5	M10	M10x35
125	167	122	45	22	30	51	86,5	140	160	350	32	60	130	65	110	G1/8	80	150	M12	M12x40

**Foot mount Mod. B...**

Material: zinc-plated steel.  
The following is supplied:  
N° 2 feet  
N° 4 screws

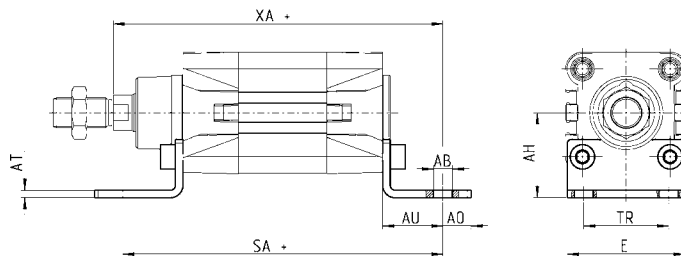

+ add the stroke

**DIMENSIONS**

Mod.	ø	AT	SA <sup>+1,25</sup>	XA <sup>+1,25</sup>	TR <sup>15 14</sup>	E	AB	AH <sup>15 16</sup>	AO	AU	Torque force (max.)
<b>B-41-32</b>	32	4	142	144	32	45	7	32	11	24	6 Nm
<b>B-41-40</b>	40	4	161	163	36	53,5	10	36	15	28	6 Nm
<b>B-41-50</b>	50	4	170	175	45	62,5	10	45	15	32	13 Nm
<b>B-41-63</b>	63	5	185	190	50	73	10	50	15	32	13 Nm
<b>B-41-80</b>	80	6	210	216	63	92	12	63	20	41	19 Nm
<b>B-41-100</b>	100	6	220	230	75	108,5	14,5	71	25	41	22 Nm
<b>B-41-125</b>	125	7	250	270	90	132	16,5	90	25	45	26 Nm

**Front and rear flange Mod. D-E...**

Material: aluminium.  
The following is supplied:  
N° 1 flange  
N° 4 screws

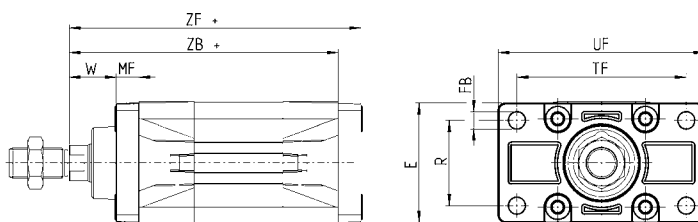
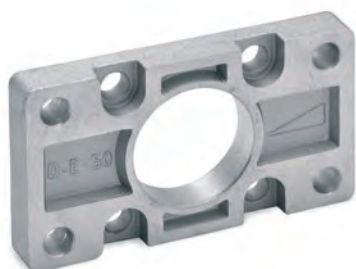

+ add the stroke

**DIMENSIONS**

Mod.	ø	W <sup>2</sup>	MF	ZB <sup>15 14</sup>	TF <sup>15 14</sup>	R <sup>15 14</sup>	UF	E	FB <sup>13</sup>	ZF <sup>+1,25</sup>	Torque force (max.)
<b>D-E-41-32</b>	32	16	10	120	64	32	86	45	7	130	6 Nm
<b>D-E-41-40</b>	40	20	10	135	72	36	88	52	9	145	6 Nm
<b>D-E-41-50</b>	50	25	12	143	90	45	110	63	9	155	13 Nm
<b>D-E-41-63</b>	63	25	12	158	100	50	116	73	9	170	13 Nm
<b>D-E-41-80</b>	80	30	16	174	126	63	148	95	12	190	19 Nm
<b>D-E-41-100</b>	100	35	16	189	150	75	176	115	14	205	22 Nm
<b>D-E-41-125</b>	125	45	20	225	180	90	224	135	16	245	26 Nm

**Rear trunnion, female Mod. C... and CH...**

Material: aluminium.  
The following is supplied:  
N° 1 female trunnion  
N° 4 screws

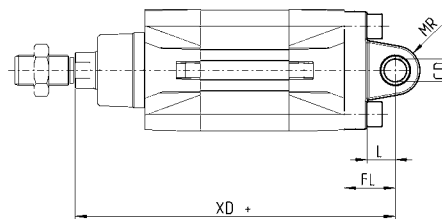
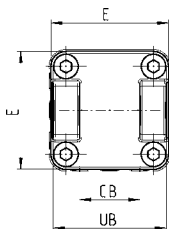

+ add the stroke

**DIMENSIONS**

Mod.	∅	CD <sup>H9</sup>	L	FL	XD <sup>H1.6</sup>	MR	E	CB <sup>H14</sup>	UB <sup>H14</sup>	Torque force (max.)
<b>C-41-32</b>	32	10	12	22	142	10	45	26	45	6Nm
<b>C-41-40</b>	40	12	15	25	160	13	52	28	52	6Nm
<b>C-41-50</b>	50	12	15	27	170	13	63	32	60	13Nm
<b>C-41-63</b>	63	16	20	32	190	15	73	40	70	13Nm
<b>C-H-41-80</b>	80	16	24	36	210	15	95	50	90	19Nm
<b>C-H-41-100</b>	100	20	29	41	230	18	115	60	110	26Nm
<b>C-H-41-125</b>	125	25	30	50	275	25	135	70	130	26Nm

**Front trunnion, female Mod. H... and C-H...**

Material: aluminium.  
The following is supplied:  
N° 1 female trunnion  
N° 4 screws

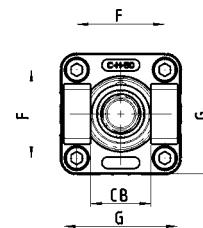
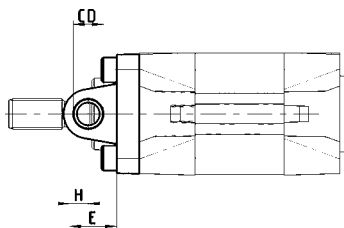
**DIMENSIONS**

Mod.	∅	CD <sup>H9</sup>	E	H	D	MR	F	G	CB <sup>H14</sup>	UB <sup>H14</sup>
<b>H-41-32</b>	32	10	16	4	120	10	32,5	45	26	45
<b>H-41-40</b>	40	12	20	5	135	13	38	52	28	52
<b>H-41-50</b>	50	12	25	10	143	13	46,5	63	32	60
<b>H-60-63</b>	63	16	25	5	158	15	56,5	73	40	70
<b>C-H-41-80</b>	80	16	34	10	174	15	72	95	50	90
<b>C-H-41-100</b>	100	20	39	10	189	18	89	115	60	110
<b>C-H-41-125</b>	125	25	45	15	225	25	110	135	70	130

**Rear trunnion, male Mod. L...**

Material: aluminium.  
The following is supplied:  
N° 1 male trunnion  
N° 4 screws

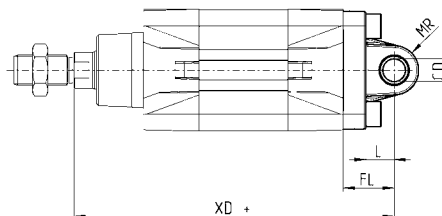
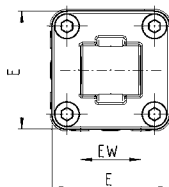

+ add the stroke

**DIMENSIONS**

Mod.	ø	CD <sup>H9</sup>	L	FL	XD <sup>-1,6</sup>	MR	E	EW <sup>-0,2-0,6</sup>	Torque force (max.)
<b>L-41-32</b>	32	10	12	22	142	9	45	26	6Nm
<b>L-41-40</b>	40	12	15	25	160	13	52	28	6Nm
<b>L-41-50</b>	50	12	15	27	170	13	63	32	13Nm
<b>L-41-63</b>	63	16	20	32	190	15	73	40	13Nm
<b>L-41-80</b>	80	16	24	36	210	15	95	50	19Nm
<b>L-41-100</b>	100	20	29	41	230	18	115	60	26Nm
<b>L-41-125</b>	125	25	30	50	275	25	135	70	26Nm

**Centre trunnion Mod. F...**

Material: zinc-plated brass.  
The following is supplied:  
N° 1 centre trunnion  
N° 4 screws  
N° 4 fixing elements

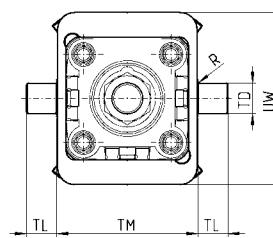
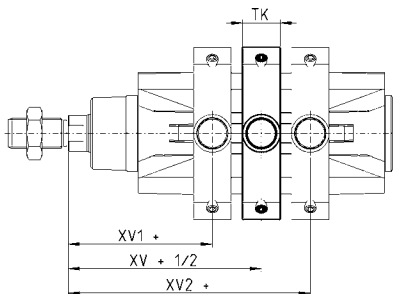

+ add the stroke

**DIMENSIONS**

Mod.	ø	XV <sup>-2</sup>	XV1 <sup>-2</sup>	XV2 <sup>-2</sup>	TM <sup>h14</sup>	TK	TD <sup>ø9</sup>	TL <sup>h14</sup>	UW	R
<b>F-61-32</b>	32	62	73	84	50	20	12	12	70	0,1
<b>F-61-40</b>	40	69	82,5	96	63	20	16	16	78	0,15
<b>F-61-50</b>	50	76,5	90	103,5	75	20	16	16	91	0,15
<b>F-61-63</b>	63	86	97,5	109	90	25	20	20	94	0,15
<b>F-61-80</b>	80	94,5	110	125,5	110	25	20	20	130	0,15
<b>F-61-100</b>	100	104,5	120	135,5	132	30	25	25	145	0,2
<b>F-61-125</b>	125	123	145	167	160	30	25	25	155	0,2

## Accessory combination Mod. C+L+S

Material: aluminium.

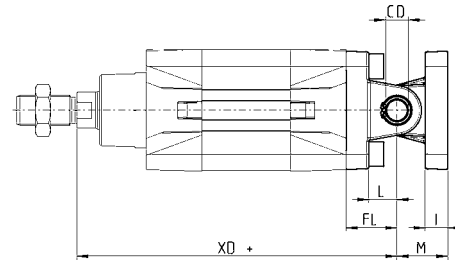
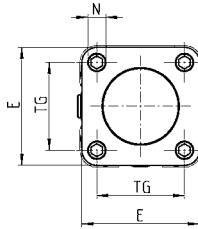

+ add the stroke

## DIMENSIONS

ø	CD <sup>H9</sup>	L	FL	XD <sup>+1,4</sup>	TG	E	I	M	N	Torque force (max.)
32	10	12	22	142	32,5	45	10	22	6,5	6Nm
40	12	15	25	160	38	52	10	25	6,5	6Nm
50	12	15	27	170	46,5	63	12	27	9	13Nm
63	16	20	32	190	56,5	73	12	32	9	13Nm
80	16	24	36	210	72	95	12	36	11	19Nm
100	20	29	41	230	89	115	12	41	11	22Nm
125	25	30	50	275	110	135	20	50	13	26Nm

## 90° male trunnion Mod. ZC...

Material: aluminium.

The following is supplied :

N° 1 support

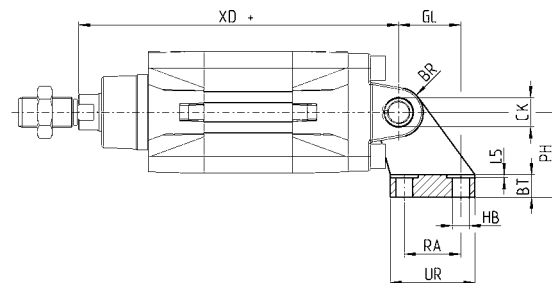
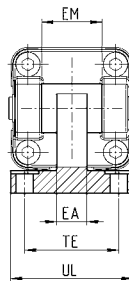

+ add the stroke

## DIMENSIONS

Mod.	ø	EB <sup>H13</sup>	CK <sup>H9</sup>	HB <sup>H13</sup>	XD	TE <sup>S14</sup>	UL <sup>MAX</sup>	EA <sup>MAX</sup>	GL <sup>S14</sup>	L5 <sup>MAX</sup>	RA <sup>S14</sup>	EM	UR <sup>S14</sup>	PH <sup>S15</sup>	BT	BR <sup>MAX</sup>	
<b>ZC-32</b>	32	11	10	6,6	154	38	51	10	21	1,6	18	26	31	32	8	10	
<b>ZC-40</b>	40	11	12	6,6	173	41	54	15	24	1,6	22	28	-0,2	35	36	10	11
<b>ZC-50</b>	50	15	12	9	188	50	65	16	33	1,6	30	32	-0,6	45	45	12	13
<b>ZC-63</b>	63	15	16	9	209,5	52	67	16	37	1,6	35	40		50	50	12	15
<b>ZC-80</b>	80	18	16	11	237	66	86	20	47	2,5	40	50		60	63	14	15
<b>ZC-100</b>	100	18	20	11	260	76	96	20	55	2,5	50	60	-0,5	70	71	15	19
<b>ZC-125</b>	125	20	25	14	315	94	124	30	70	3,2	60	70	-1,5	90	90	20	22,5

**Trunnion ball-joint Mod. R\*...**

Material: aluminium.  
 \*not according to standard.  
 The following is supplied:  
 N° 1 trunnion ball joint  
 N° 4 screws

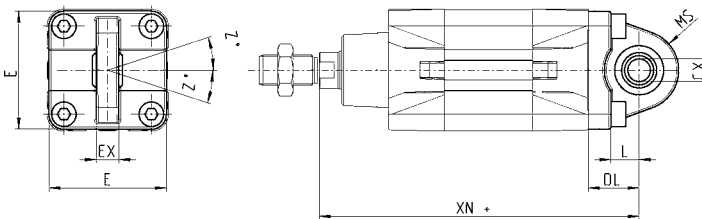
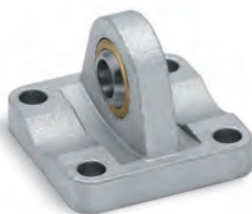

+ add the stroke

**DIMENSIONS**

Mod.	ø	CX	L	DL	XN <sup>±1.6</sup>	MS	E	EX <sup>±1</sup>	Z°	Torque force (max.)
<b>R-41-32</b>	32	10	12	22	142	16	45	14	4	6Nm
<b>R-41-40</b>	40	12	15	25	160	20	52	16	4	6Nm
<b>R-41-50</b>	50	12	15	27	170	20	63	16	4	13Nm
<b>R-41-63</b>	63	16	20	32	190	24	73	21	4	13Nm
<b>R-41-80</b>	80	16	24	36	210	24	95	21	4	19Nm
<b>R-41-100</b>	100	20	29	41	230	30	115	25	4	22Nm

**Counter bracket for centre trunnion Mod. BF...**

Material: aluminium.  
 The following is supplied:  
 N° 2 supports

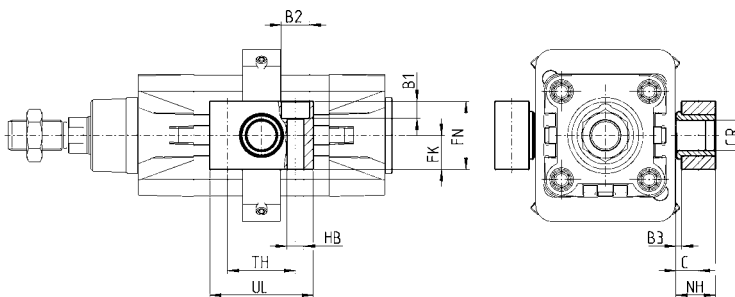

**DIMENSIONS**

Mod.	ø	CR	NH	C	b3	TH	UL	FK	FN	B1	B2	HB
<b>BF-32</b>	32	12	15	7,5	3	32	46	15	30	6,8	11	6,6
<b>BF-40-50</b>	40-50	16	18	9	3	36	55	18	36	9	15	9
<b>BF-63-80</b>	63-80	20	20	10	3	42	65	20	40	11	18	11
<b>BF-100-125</b>	100-125	25	25	12,5	3,5	50	75	25	50	13	20	14

**Assembly**

The horizontal mounting foot allows the connection between the valve or the solenoid valve and the cylinder, forming a compact pneumatic working unit, which is easy to apply.

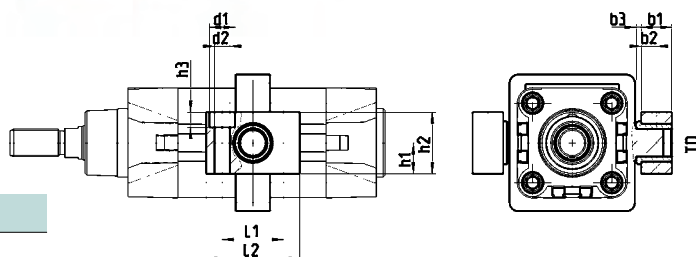

Mod.

**PCV-61-K3** to connect valves-solenoid valves Series 3**PCV-61-K4** to connect valves-solenoid valves Series 4 port G1/4**PCV-61-KE** to connect valves-solenoid valves Series E**PCV-61-K8** to connect valves-solenoid valves Series 4 port G1/8**Rod Fork End Mod. G...**

ISO 8140.

Material: zinc-plated steel.

**DIMENSIONS**

Mod.	ø	øCK	LE	CM	CL	ER	CE	KK	B	øB1
<b>G-25-32</b>	32	10	20	10	20	12	40	M10x1,25	26	18
<b>G-40</b>	40	12	24	12	24	14	48	M12x1,25	32	20
<b>G-50-63</b>	50-63	16	32	16	32	19	64	M16x1,5	40	26
<b>G-80-100</b>	80-100	20	40	20	40	25	80	M20x1,5	48	34
<b>G-41-125</b>	125	30	55	30	55	28	110	M27x2	74	48

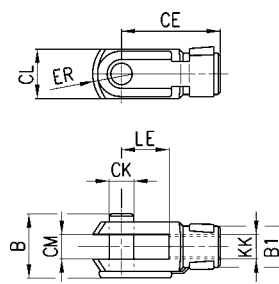
**Swivel Ball Joint Mod. GA...**

ISO 8139.

Material: zinc-plated steel.

**DIMENSIONS**

Mod	ø	øCN <sup>17</sup>	U	EN	ER	AX	CE	KK	øT	Z	SW
<b>GA-32</b>	32	10	10,5	14	14	20	43	M10x1,25	15	6,5	17
<b>GA-40</b>	40	12	12	16	16	22	50	M12x1,25	17,5	6,5	19
<b>GA-50-63</b>	50-63	16	15	21	21	28	64	M16x1,5	22	7,5	22
<b>GA-80-100</b>	80-100	20	18	25	25	33	77	M20x1,5	27,5	7	30
<b>GA-41-125</b>	125	30	25	37	35	51	110	M27x2	40	7,5	41

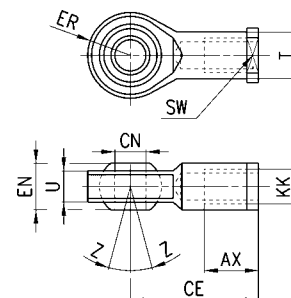

**Piston Rod Socket Joint Mod. GY...**

Material: zama and zinc-plated steel.

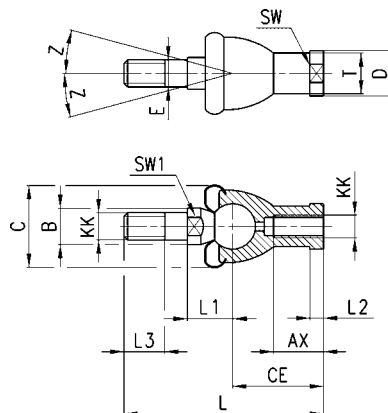

**DIMENSIONS**

Mod.	ø	KK	L	CE	L2	AX	SW	SW1	L1	L3	øT	øD	E	øB	øC	Z
<b>GY-25-32</b>	32	M10x1,25	74	35	6,5	18	17	11	19,5	15	15	19	10	14	28	15
<b>GY-40</b>	40	M12x1,25	84	40	6,5	20	19	17	22	17	17,5	22	12	19	32	15
<b>GY-50-63</b>	50-63	M16x1,5	112	50	8	27	22	19	27,5	23	22	27	16	22	40	11
<b>GY-80-100</b>	80-100	M20x1,5	133	63	10	38	30	24	31,5	25	27,5	34	20	29	45	7,5

**Clevis Pin Mod. S...**

The following is supplied:  
 N° 1 clevis pin (stainless steel 303)  
 N° 2 Seeger (steel)

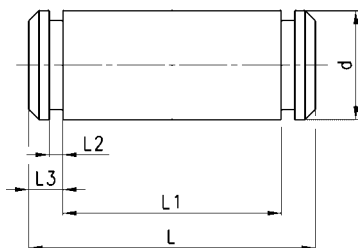

**DIMENSIONS**

Mod.	ø	d	L	L1	L2 <sup>H13</sup>	L3
<b>S-32</b>	32	10	52	46	1,1	3
<b>S-40</b>	40	12	59	53	1,1	3
<b>S-50</b>	50	12	67	6	1,1	3
<b>S-63</b>	63	16	77	71	1,1	3
<b>S-80</b>	80	16	97	91	1,1	3
<b>S-100</b>	100	20	121	111	1,3	5
<b>S-125</b>	125	25	140,5	132	1,3	4,25

**Piston Rod Lock Nut Mod. U...**

UNI EN ISO 4035.  
 Material: zinc-plated steel.  
 Included on all Series 61 cylinders.

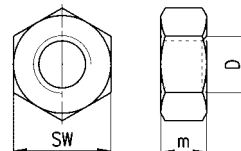

**DIMENSIONS**

Mod.	ø	D	m	SW
<b>U-25-32</b>	32	M10x1,25	6	17
<b>U-40</b>	40	M12x1,25	7	19
<b>U-50-63</b>	50-63	M16x1,5	8	24
<b>U-80-100</b>	80-100	M20x1,5	9	30
<b>U-41-125</b>	125	M27x2	12	41