

INLINE flow sensor for continuous flow measurement

- Economic integration in pipe systems without any additional piping
- 3-wire frequency pulse version to directly interface with PLC's (both PNP and NPN)
- Connection to Bürkert devices in remote versions

Type 8030 can be combined with...

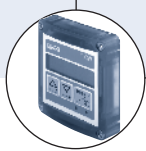

Type 8025

Flow transmitter remote version



Type 8623-2

PI flow controller



Type 2712 (8630)

Continuous TopControl system

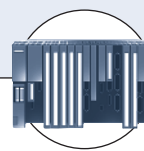

PLC

The paddle-wheel flow sensor for continuous flow measurement is especially designed for use in neutral, slightly aggressive, solid free liquids. The sensor is made up of a compact fitting (S030) and an electronic module (SE30) quickly and easily connected together by a Quarter-Turn. The Bürkert designed fitting system ensures simple installation of the sensors into all pipe diameters from 1/4" to 2 1/2" (DN 06 to 65). The sensor produces a frequency pulse signal, proportional to the flow rate, which can easily be transmitted and processed by a Bürkert remote transmitter / indicator (Type 8025/8032).

General data	
Compatibility	with fittings S030 (see corresp. datasheet)
Materials	
Housing, cover	PC
Cable plug	PA
Materials wetted parts	
Fitting, sensor armature	Brass, stainless steel 1.4404/316L PVC, PP, PVDF
Paddle-wheel	PVDF
Axis, bearing / Seal	Ceramics / FKM (EPDM option)
Electrical connection	Cable plug EN 175301-803
Connection cable	1.5 mm ² max. cross section; max. 164 ft. length, shielded
Complete device data (fitting + electronic module)	
Pipe diameter	1/4" to 2 1/2" (DN 06 to 65)
Measuring range	1.0 f/s to 32.8 f/s (0.3 to 10 m/s)
Fluid temperature with	
PVC fitting	32°F up to 122°F (0°C up to 50°C)
PP fitting	32°F up to 176°F (0°C up to 80°C)
St.st., brass, PVDF fitting	5°F up to 176°F (-15°C up to 100°C)
Fluid pressure max.	145 PSI (PN10) (with plastic fitting) 232 PSI (PN16) (with metal fitting) (580 PSI (PN 40) on request, see S030 datasheet)
Viscosity	300 cSt. max.
Accuracy	
Teach-In	≤ ± 0.5% of F.S.* (at 32.8 f/s) ¹⁾
Standard K-factor	≤ ± (0.5% of F.S.* + 2.5% of Reading) ¹⁾
Linearity	≤ ± 0.5% of F.S.* (at 32.8 f/s) ¹⁾
Repeatability	≤ 0.4% of Reading ¹⁾

Electrical data	
Power supply	12-36 V DC (via Bürkert transmitter for "Low Power" version) and 5-15 V DC ("Low Voltage" version)
Current consumption	with sensor
Pulse version	≤ 30 mA
Pulse "Low Power" vers.	≤ 0.8 mA
Pulse "Low Voltage" vers.	≤ 1.0 mA
Output: Frequency	
Hall (Pulse) version	Transistor NPN/PNP, open collector, max. 100 mA, frequency: 0...300 Hz; duty cycle 1/2
Hall (Pulse)	Transistor NPN, open collector, max. 10 mA, frequency: 0...300 Hz; duty cycle 1/2
"Low Power" version	Transistor NPN, open collector, max. 30 mA, frequency: 0...300 Hz; duty cycle 1/2
"Low Voltage" version	Transistor NPN, open collector, max. 30 mA, frequency: 0...300 Hz; duty cycle 1/2
Reversed polarity of DC	Protected
Environment	
Ambient temperature	5°F up to 140°F (-15°C up to +60°C) (operating and storage)
Relative humidity	≤ 80%, non condensated
Standards and approvals	
Protection class	IP65 with connector plugged-in and tightened
Standard	
EMC	EN 61000-6-2, 61000-6-3
Vibration	EN 60068-2-6
Shock	EN 60068-2-27

* F.S. = Full scale (32.8 f/s)

1) Under reference conditions i.e. measuring fluid = water, ambient and water temperature = 68°F, applying the minimum inlet and outlet pipe straights, matched inside pipe dimensions.

Accuracy diagram

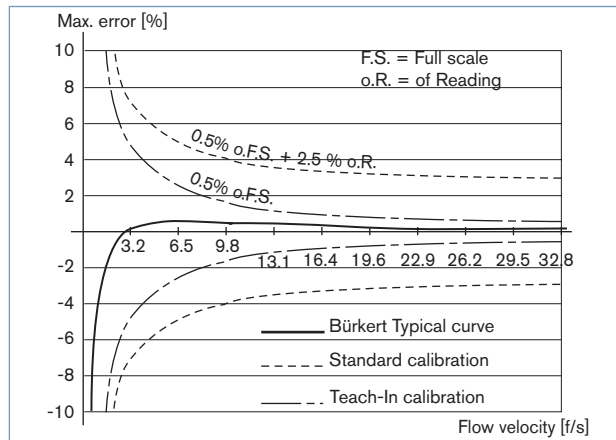

Design and principle of operation

The flow sensor 8030 is built up with an electronic module SE30 associated to a fitting S030 with integrated measurement paddle-wheel. This connection is made by means of a Quarter-Turn.

In a 3-wire system, the signal can be displayed or processed directly. The output signal is provided via cable plug according to EN 175301-803.

When liquid flows through the pipe, the paddle-wheel is set in rotation, producing a measuring signal in the transducer. The frequency modulated induced voltage is proportional to the flow velocity of the fluid. A conversion coefficient (K factor, available in the instruction manual of the fitting), specific to each pipe (size and material) enables the conversion of this frequency into flow rate.

Two electronic module versions with frequency output are available:

- with one pulse output (either NPN or PNP transistor output depending on wiring). An external power supply of 12-36 V DC is required. It is designed for connection to any system with open collector NPN or PNP frequency input.
- with one pulse "Low Power" output (NPN transistor output). An external power supply of 12-36 V DC is required. Can only be connected to separate versions of flow transmitters Type 8025/8032.

Pressure / temperature chart

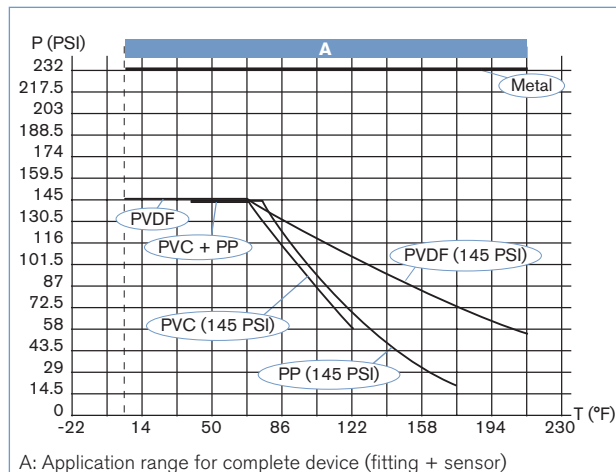

Installation

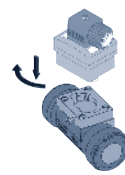

The 8030 flow sensor can easily be installed into any Bürkert INLINE fitting system Type S030, by means of a Quarter-Turn. Minimum straight upstream and downstream distances must be observed. According to the pipe's design, necessary distances can be bigger or use a flow conditioner to obtain the best accuracy.

For more information, please refer to EN ISO 5167-1.

EN ISO 5167-1 prescribes the straight inlet and outlet distances that must be complied with when installing fittings in pipe lines in order to achieve calm flow conditions. The most important layouts that could lead to turbulence in the flow are shown below, together with the associated prescribed minimum inlet and outlet distances. These ensure calm, problem-free measurement conditions at the measurement point.

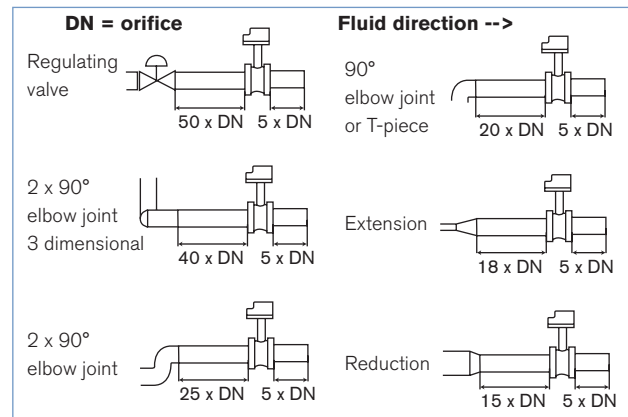

The flow rate sensor can be installed into either horizontal or vertical pipes.

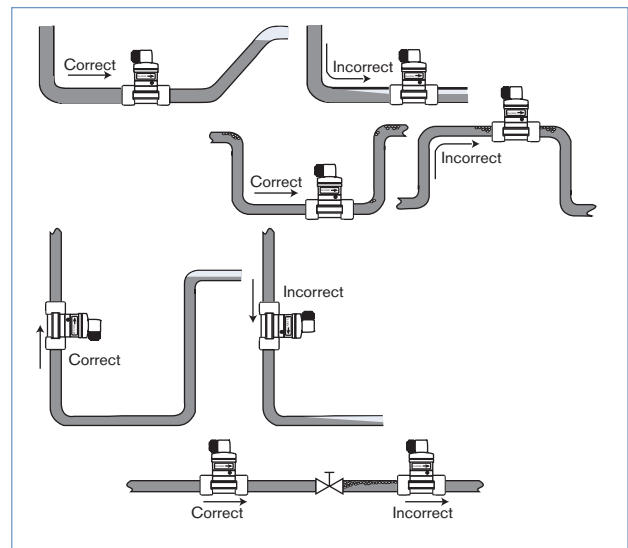

Pressure and temperature ratings must be respected according to the selected fitting material.

The suitable pipe size is selected using the diagram Flow / Velocity / DN.

The sensor is not designed for gas flow measurement.

Selection of fitting / pipe size

Example:

- Specification of nominal flow: 50 gpm
- Ideal flow velocity: 6 – 8 f/s
- For these specifications, the diagram indicates a pipe size of 1 1/2" (DN40) [or 2" (DN50) for (*) mentioned fittings]

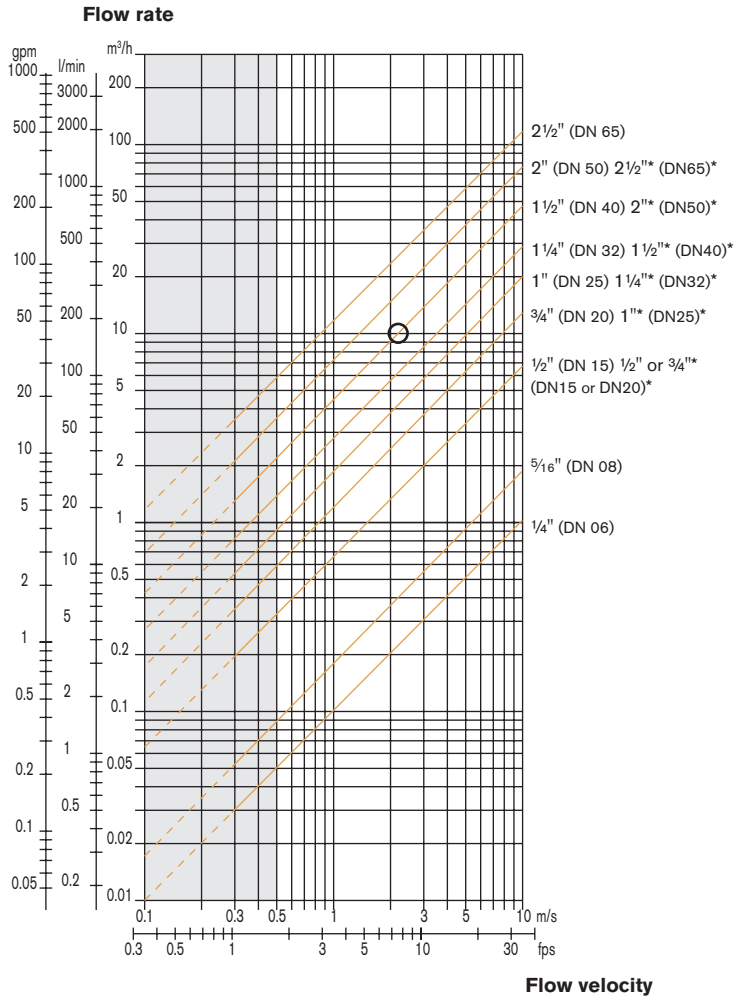

- * For following fittings:
- with external threads acc. to SMS 1145
 - with weld-ends acc. to SMS 3008, BS 4825 / ASME BPE or DIN 11850 Series 2
 - Tri-Clamp® acc. to SMS 3017 / ISO 2852, BS 4825 / ASME BPE or DIN 32676

Tri-Clamp® is a registered Trademark of Alfa Laval Inc.

Dimensions

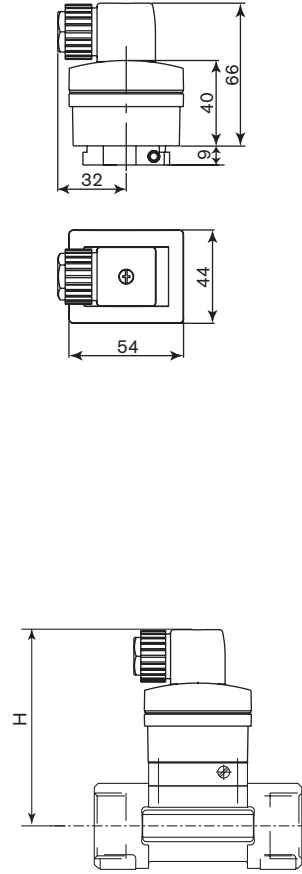

DN [mm]	H [mm]
06	95.5
08	95.5
15	100.5
20	98.0
25	98.0
32	102.0
40	105.5
50	112.0
65	112.0

INLINE fitting dimensions

Internal thread connection

G, NPT or Rc

in stainless steel (316L - 1.4404) or
brass (CuZn39Pb2)

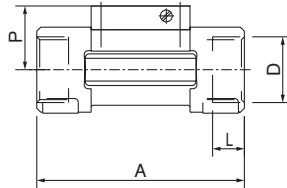

DN [mm]	P [mm]	A [mm]	D [inch]	L [mm]
15	34.5	84.0	G 1/2	16.0
			NPT 1/2	17.0
			Rc 1/2	15.0
20	32.0	94.0	G 3/4	17.0
			NPT 3/4	18.3
			Rc 3/4	16.3
25	32.2	104.0	G 1	23.5
			NPT 1	18.0
			Rc 1	18.0
32	35.8	119.0	G 1 1/4	23.5
			NPT 1 1/4	21.0
			Rc 1 1/4	21.0
40	39.6	129.0	G 1 1/2	23.5
			NPT 1 1/2	20.0
			Rc 1 1/2	19.0
50	45.7	148.5	G 2	27.5
			NPT 2	24.0
			Rc 2	24.0

External thread connection

G, NPT or Rc

in stainless steel (316L - 1.4404),
brass (CuZn39Pb2),

PVC (only DN 6 and DN 8)
or PVDF (only DN 8)

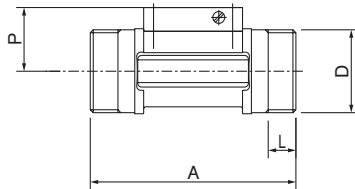

DN [mm]	P [mm]	A [mm]	D [inch]	[mm]	L [mm]
06	29.5	90.0	G1/4 or G1/2	-	14.0
08	29.5	90.0	1/2**	M 16 x 1.5	14.0
15	34.5	84.0	G 3/4	-	11.5
20	32.0	94.0	G 1	-	13.5
25	32.2	104.0	G 1 1/4	-	14.0
32	35.8	119.0	G 1 1/2	-	18.0
40	39.6	129.0	-	M 55 x 2	19.0
50	45.7	148.5	-	M 64 x 2	20.0

** G, NPT, RC according to fitting version

External thread connection

SMS 1145,

in stainless steel (316L - 1.4404)

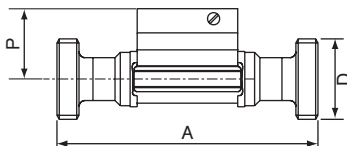

DN [mm]	P [mm]	A [mm]	D
25	32.0	130	Rd 40 x 1/6"
40	35.8	164	Rd 60 x 1/6"
50	39.6	173	Rd 70 x 1/6"

INLINE fitting dimensions

Weld ends connection

EN ISO 1127 / ISO 4200, SMS 3008,
BS 4825 / ASME BPE or DIN 11850 Series 2
in stainless steel (316L - 1.4404)

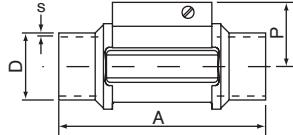

DN	P	A	Standard	D	s
[mm]	[mm]	[mm]		[mm]	[mm]
08	-	-	EN ISO 1127 / ISO 4200	-	-
	-	-	SMS 3008	-	-
	-	-	ASME BPE	-	-
	29.5	90.0	DIN 11850 Series 2	13.00	1.50
15	34.5	84.0	EN ISO 1127 / ISO 4200	21.30	1.60
	-	-	SMS 3008	-	-
	-	-	ASME BPE	-	-
20	34.5	84.0	DIN 11850 Series 2	19.0	1.50
	32.0	94.0	EN ISO 1127 / ISO 4200	26.9	1.60
	-	-	SMS 3008	-	-
25	34.5	84.0	ASME BPE	19.05	1.65
	34.5	84.0	DIN 11850 Series 2	23.00	1.50
	32.2	104.0	EN ISO 1127 / ISO 4200	33.70	2.00
	32.0	94.0	SMS 3008	25.00	1.20
32	32.0	94.0	BS 4825 / ASME BPE	25.40	1.65
	32.0	94.0	DIN 11850 Series 2	29.00	1.50
	35.8	119.0	EN ISO 1127 / ISO 4200	42.40	2.00
	-	-	SMS 3008	-	-
40	32.2	104.0	BS 4825 / ASME BPE	32.00	1.65
	32.2	104.0	DIN 11850 Series 2	35.00	1.50
	39.6	129.0	EN ISO 1127 / ISO 4200	48.30	2.00
	35.8	119.0	SMS 3008	38.00	1.20
50	35.8	119.0	BS 4825 / ASME BPE	38.10	1.65
	35.8	119.0	DIN 11850 Series 2	41.00	1.50
	45.7	148.5	EN ISO 1127 / ISO 4200	60.30	2.60
	39.6	128.0	SMS 3008	51.00	1.20
65	39.6	128.0	BS 4825 / ASME BPE	50.80	1.65
	39.6	128.0	DIN 11850 Series 2	53.00	1.50
	-	-	EN ISO 1127 / ISO 4200	-	-
	45.7	147.0	SMS 3008	63.50	1.60
-	45.7	147.0	BS 4825 / ASME BPE	63.50	1.65
	-	-	DIN 11850 Series 2	-	-

INLINE fitting dimensions

Tri-Clamp® connection

ISO (for pipe EN ISO 1127 / ISO 4200), SMS 3017 / ISO 2852*,
BS 4825 / ASME BPE* or DIN 32676

in stainless steel (316L - 1.4404)

* Available with internal surface finish Ra = 0.8 µm

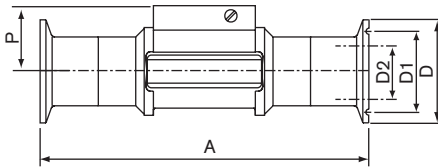

DN	P	A	Standard	D2	D1	D
[mm]	[mm]	[mm]		[mm]	[mm]	[mm]
08	-	-	ISO (for pipe EN ISO 1127 / ISO 4200)	-	-	-
	-	-	SMS 3017 / ISO 2852	-	-	-
	-	-	ASME BPE	-	-	-
	29.5	125	DIN 32676	10.00	27.5	34.0
15	34.5	130	ISO (for pipe EN ISO 1127 / ISO 4200)	18.10	27.5	34.0
	-	-	SMS 3017 / ISO 2852	-	-	-
	-	-	ASME BPE	-	-	-
	29.5	119	DIN 32676	16.00	27.5	34.0
20	32.0	150	ISO (for pipe EN ISO 1127 / ISO 4200)	23.70	43.5	50.5
	-	-	SMS 3017 / ISO 2852	-	-	-
	34.5	119	ASME BPE	15.75	19.6	25.0
	34.5	119	DIN 32676	20.00	27.5	34.0
25	32.2	160	ISO (for pipe EN ISO 1127 / ISO 4200)	29.70	43.5	50.5
	32.0	129	SMS 3017 / ISO 2852	22.60	43.5	50.5
	32.0	129	BS 4825 / ASME BPE	22.10	43.5	50.5
	32.0	136	DIN 32676	26.00	43.5	50.5
32	35.8	180	ISO (for pipe EN ISO 1127 / ISO 4200)	38.40	43.5	50.5
	-	-	SMS 3017 / ISO 2852	-	-	-
	-	-	BS 4825 / ASME BPE	-	-	-
	-	-	DIN 32676	-	-	-
40	39.6	200	ISO (for pipe EN ISO 1127 / ISO 4200)	44.30	56.5	64.0
	35.8	161	SMS 3017 / ISO 2852	35.60	43.5	50.5
	35.8	161	BS 4825 / ASME BPE	34.80	43.5	50.5
	35.8	161	DIN 32676	38.00	43.5	50.5
50	45.7	230	ISO (for pipe EN ISO 1127 / ISO 4200)	55.10	70.5	77.5
	39.6	192	SMS 3017 / ISO 2852	48.60	56.5	64.0
	39.6	192	BS 4825 / ASME BPE	47.50	56.5	64.0
	39.6	170	DIN 32676	50.00	56.5	64.0
65	-	-	ISO (for pipe EN ISO 1127 / ISO 4200)	-	-	-
	45.7	216	SMS 3017 / ISO 2852	60.30	70.5	77.5
	45.7	216	BS 4825 / ASME BPE	60.20	70.5	77.5
	-	-	DIN 32676	-	-	-

Flange connection

DIN 2633 (ISO PN16), ANSI B16-5-1988 or JIS 10 K

in stainless steel (316L - 1.4404)

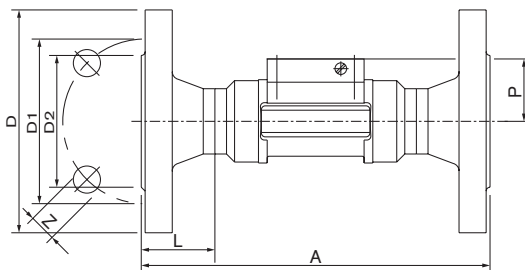

DN	P	A	Standard	L	Z	D2	D1	D				
[mm]	[mm]	[mm]		[mm]	[mm]	[mm]	[mm]	[mm]				
15	34.5	130	DIN	23.5	4x14.0	45.0	65.0	95.0				
		130	ANSI						4x15.8	34.9	60.3	89.0
		152	JIS						4x15.0	51.0	70.0	95.0
20	32.0	150	DIN	28.5	4x14.0	58.0	75.0	105.0				
		150	ANSI						4x15.8	42.9	69.8	99.0
		178	JIS						4x15.0	56.0	75.0	100.0
25	32.2	160	DIN	28.5	4x14.0	68.0	85.0	115.0				
		160	ANSI						4x15.8	50.8	79.4	108.0
		216	JIS						4x19.0	67.0	90.0	125.0
32	35.8	180	DIN	31.0	4x18.0	78.0	100.0	140.0				
		180	ANSI						4x15.8	63.5	88.9	117.0
		229	JIS						4x19.0	76.0	100.0	135.0
40	39.6	200	DIN	36.0	4x18.0	88.0	110.0	150.0				
		200	ANSI						4x15.8	73.0	98.4	127.0
		241	JIS						4x19.0	81.0	105.0	140.0
50	45.7	230	DIN	41.0	4x18.0	102.0	125.0	165.0				
		230	ANSI						4x19.0	92.1	120.6	152.0
		267	JIS						4x19.0	96.0	120.0	155.0

INLINE fitting dimensions

True union connection

DIN 8063, ASTM D 1785/76 or JIS K in PVC,
DIN 16962 in PP or
ISO 10931 in PVDF

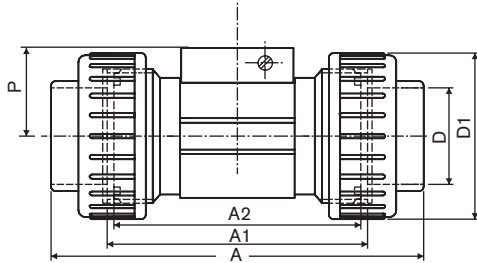

DN	P	A	Standard	A1	A2	D	D1
[mm]	[mm]	[mm]		[mm]	[mm]	[mm]	[mm]
08*	29.5	122.0 - -	DIN / ISO ASTM JIS	92 - -	90 - -	12.00 - -	- - -
15	34.5	128.0 130.0 129.0	DIN / ISO ASTM JIS	96	90	20.00 21.30 18.40	43
20	32.0	144.0 145.6 145.0	DIN / ISO ASTM JIS	106	100	25.00 26.70 26.45	53
25	32.2	160.0 161.4 161.0	DIN / ISO ASTM JIS	116	110	32.00 33.40 32.55	60
32	35.8	168.0 170.0 169.0	DIN / ISO ASTM JIS	116	110	40.00 42.20 38.60	74
40	39.6	188.0 190.2 190.0	DIN / ISO ASTM JIS	127	120	50.00 48.30 48.70	83
50	45.7	212.0 213.6 213.0	DIN / ISO ASTM JIS	136	130	63.00 60.30 60.80	103

* Only available in PVC

Spigot connection

DIN 8063 in PVC
DIN 16962 in PP or
ISO 10931 in PVDF

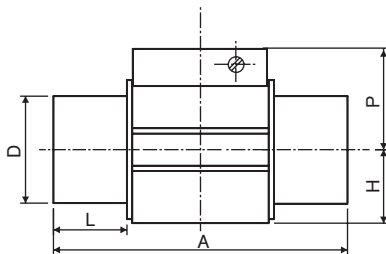

DN	P	A	Standard	L	D	H
[mm]	[mm]	[mm]		[mm]	[mm]	[mm]
15	34.5	90 85 85	DIN 8063 DIN 16962 ISO 10931	16.5 14.0 14.0	20	17.5
20	32.0	100 92 92	DIN 8063 DIN 16962 ISO 10931	20.0 16.0 16.0	25	17.5
25	32.2	110 95 95	DIN 8063 DIN 16962 ISO 10931	23.0 18.0 18.0	32	21.5
32	35.8	110 100 100	DIN 8063 DIN 16962 ISO 10931	27.5 20.0 20.0	40	27.5
40	39.6	120 106 106	DIN 8063 DIN 16962 ISO 10931	30.0 23.0 23.0	50	31.5
50	45.7	130 110 110	DIN 8063 DIN 16962 ISO 10931	37.0 27.0 27.0	63	39.5

Ordering chart for fitting S030

Port connection	Seal	Standard	Item no. 1/4" (DN 06) orifice** w/ male 1/4" port	Item no. 1/4" (DN 06) orifice** w/ male 1/2" port	Item no. 5/16" (DN 08) orifice** w/ male 1/2" port	Item no. 1/2" (DN 15)	Item no. 3/4" (DN 20)	Item no. 1" (DN 25)	Item no. 1 1/4" (DN 32)	Item no. 1 1/2" (DN 40)	Item no. 2" (DN 50)	Item no. 2 1/2" (DN 65)
Brass - with PVDF paddle-wheel - Temperature max. 212°F, 232 PSI												
Internal thread	FKM	G	-	-	-	423 980	423 981	423 982	423 983	423 984	423 985	-
		NPT	-	-	-	423 986	423 987	423 988	423 989	423 990	423 991	-
		Rc (ISO7)	-	-	-	423 992	423 993	423 994	423 995	423 996	423 997	-
External thread	FKM	G	552 557	552 527	444 023	423 998	423 999	424 000	424 001	424 002	424 003	-
		NPT	-	-	449 182	-	-	-	-	-	-	-
		Rc (ISO7)	-	-	448 668	-	-	-	-	-	-	-
Metric	FKM		-	-	16x1.5mm 552 526	-	-	-	-	-	-	
Stainless steel - with PVDF paddle-wheel - Temperature max. 212°F, 232 PSI												
Internal thread	FKM	G	-	-	-	424 004	424 005	424 006	424 007	424 008	424 009	-
		NPT	-	-	-	424 010	424 011	424 012	424 013	424 014	424 015	-
		Rc (ISO7)	-	-	-	424 016	424 017	424 018	424 019	424 020	424 021	-
External thread	FKM	G	552 733	552 559	444 029	424 022	424 023	424 024	424 025	424 026	424 027	-
		NPT	-	-	449 050	-	-	-	-	-	-	-
		Rc (ISO7)	-	-	448 669	-	-	-	-	-	-	-
Weld ends	FKM	SMS 1145	-	-	-	-	-	443 306	-	443 307	443 308	-
		EN ISO 1127 / ISO 4200	-	-	552 845 ¹⁾	424 028	424 029	424 030	424 031	424 032	424 033	-
		SMS 3008	-	-	-	-	-	443 298	-	443 299	443 300	443 374
	EPDM	BS 4825 / ASME BPE	-	-	-	-	443 369 ²⁾	443 370	443 371	443 372	443 373	443 374
		DIN 11850 S2	-	-	551 788	551 789	551 790	551 791	-	551 792	551 793	-
		Tri-Clamp®	FKM	ISO (for pipe EN ISO 1127/ISO4200)	-	-	-	424 034	424 035	424 036	424 037	424 038
Tri-Clamp®	EPDM	SMS 3017 / ISO 2852	-	-	-	-	-	443 302	-	443 303	443 304	443 399
		SMS 3017 / ISO 2852*	-	-	-	-	-	443 387	-	443 388	443 389	443 720
		BS 4825 / ASME BPE	-	-	-	-	443 395	443 396	-	443 397	443 398	443 399
		BS 4825 / ASME BPE*	-	-	-	-	443 400	443 717	-	443 718	443 719	443 720
		DIN 32676	-	-	551 794	551 795	551 796	551 797	-	551 798	551 799	-
Flange	FKM	DIN 2633	-	-	-	424 040	424 041	424 042	424 043	424 044	424 045	-
		ANSI B16-5-1988	-	-	-	424 046	424 047	424 048	424 049	424 050	424 051	-
		JIS 10K	-	-	-	430 108	430 109	430 110	430 111	430 112	430 113	-
PVC - with PVDF paddle-wheel - Temperature max. 122°F, 145 PSI												
True union	FKM	DIN 8063	-	-	444 022	423 938	423 939	423 940	423 941	423 942	423 943	-
		ASTM D 1785/76	-	-	-	423 950	423 951	423 952	423 953	423 954	423 955	-
		JIS K	-	-	-	429 072	429 073	429 074	429 075	429 076	429 077	-
Spigot	FKM	DIN 8063	-	-	-	423 944	423 945	423 946	423 947	423 948	423 949	
Extern. thr.	FKM	G	-	552 560	444 025	-	-	-	-	-	-	
True union without spigot	FKM		-	-	-	430 734	430 735	430 736	430 737	430 738	430 739	-
		EPDM	-	-	-	430 740	430 741	430 742	430 743	430 744	430 745	-
PP - with PVDF paddle-wheel - Temperature max. 176°F, 145 PSI***												
True union	FKM	DIN 16962	-	-	-	423 956	423 957	423 958	423 959	423 960	423 961	-
Spigot	FKM	DIN 16962	-	-	-	423 962	423 963	423 964	423 965	423 966	423 967	-
PVDF -with PVDF paddle-wheel - Temperature max. 212°F, 145 PSI***												
True union	FKM	ISO 10931	-	-	-	423 968	423 969	423 970	423 971	423 972	423 973	-
Spigot	FKM	ISO 10931	-	-	-	423 974	423 975	423 976	423 977	423 978	423 979	-
Extern. thr.	FKM	ISO 10931	-	-	444 028	-	-	-	-	-	-	-

* internal surface finish Ra = 0.8 µm

** reduced orifice with male external thread

*** metric weld connections only

1) EPDM seal

2) DN 20 only available in ASME BPE

8030 systems

Specifications	Item no.*
PVC Flow Sensor with Frequency Output 1/2" - 2" PVC Body with True-Union Ends, PVDF Paddle, Ceramic Shaft and Bearings. Max operating is 140 PSI and 122°F. FKM is standard seal material. 1-33 fps flow range capability.	
1/2" Flow Meter	US08402
3/4" Flow Meter	US08401
1" Flow Meter	US08400
1 1/4" Flow Meter	US08399
1 1/2" Flow Meter	US08398
2" Flow Meter	US08397
Brass Flow Sensor with Frequency Output 1/2" - 2" Brass Body with NPT Ends, PVDF Paddle, Ceramic Shaft and Bearings. Max operating is 230 PSI and 212°F. FKM is standard seal material. 1-33 fps flow range capability.	
1/2" Flow Meter	424 468
3/4" Flow Meter	424 469
1" Flow Meter	424 470
1 1/4" Flow Meter	424 471
1 1/2" Flow Meter	424 472
2" Flow Meter	424 473
PVDF Flow Sensor with Frequency Output 20mm to 63mm PVDF Body with True-Union Fusion Spigot, PVDF Paddle, Ceramic Shaft and Bearings. Max operating is 140 PSI and 122°F. FKM is standard seal material. 1-33 fps flow range capability.	
20mm Flow Meter	US08372
25mm Flow Meter	US08371
32mm Flow Meter	US08370
40mm Flow Meter	US08369
50mm Flow Meter	US08368
63mm Flow Meter	US08367
Stainless Steel Flow Sensor with Frequency Output 1/2" - 2" SS Body with NPT Ends, PVDF Paddle, Ceramic Shaft and Bearings. Max operating is 230 PSI and 212°F. FKM is standard seal material. 1-33 fps flow range capability.	
1/2" Flow Meter	424 522
3/4" Flow Meter	424 523
1" Flow Meter	424 524
1 1/4" Flow Meter	424 525
1 1/2" Flow Meter	424 526
2" Flow Meter	424 527

*8030 with PNP or NPN Hall Signal output (frequency output) 0-200HZ

8023 systems

Specifications	Item no.*
PVC 4-20 mA Blind Two Wire Flow Transmitters 1/2" - 2" PVC Body with True-Union Ends, PVDF Paddle, Ceramic Shaft and Bearings. Max operating is 140 PSI and 122°F. FKM is standard seal material. 1-33 fps flow range capability.	
1/2" Blind 4-20mA flow transmitter	US08470
3/4" Blind 4-20mA flow transmitter	US08469
1" Blind 4-20mA flow transmitter	US08468
1 1/4" Blind 4-20mA flow transmitter	US08467
1 1/2" Blind 4-20mA flow transmitter	US08466
2" Blind 4-20mA flow transmitter	US08465
Programmer (needed for any multiple number of flow meters purchased above)	130446X
Brass 4-20 mA Blind Two Wire Flow Transmitters 1/2" - 2" Brass Body with NPT Ends, PVDF Paddle, Ceramic Shaft and Bearings. Max operating is 230 PSI and 212°F. FKM is standard seal material. 1-33 fps flow range capability.	
1/2" Blind 4-20mA flow transmitter	US08414
3/4" Blind 4-20mA flow transmitter	US08413
1" Blind 4-20mA flow transmitter	US08412
1 1/4" Blind 4-20mA flow transmitter	US08411
1 1/2" Blind 4-20mA flow transmitter	US08410
2" Blind 4-20mA flow transmitter	US08409
Programmer (needed for any multiple number of flow meters purchased above)	130446X
Stainless 4-20 mA Blind Two Wire Flow Transmitters 1/2" - 2" SS Body with NPT Ends, PVDF Paddle, Ceramic Shaft and Bearings. Max operating is 230 PSI and 212°F. FKM is standard seal material. 1-33 fps flow range capability.	
1/2" Blind 4-20mA flow transmitter	US08396
3/4" Blind 4-20mA flow transmitter	US08395
1" Blind 4-20mA flow transmitter	US08394
1 1/4" Blind 4-20mA flow transmitter	US08393
1 1/2" Blind 4-20mA flow transmitter	US08392
2" Blind 4-20mA flow transmitter	US08391
Programmer (needed for any multiple number of flow meters purchased above)	130446X
PVDF 4-20 mA Blind Two Wire Flow Transmitters 20mm to 63mm PVDF Body with True-Union Fusion Spigot Ends, PVDF Paddle, Ceramic Shaft and Bearings. Max operating is 140 PSI and 212°F. FKM is standard seal material. 1-33 fps flow range capability.	
20mm Blind 4-20mA flow transmitter	US08390
25mm Blind 4-20mA flow transmitter	US08389
32mm Blind 4-20mA flow transmitter	US08388
40mm Blind 4-20mA flow transmitter	US08387
50mm Blind 4-20mA flow transmitter	US08386
63mm Blind 4-20mA flow transmitter	US08385
Programmer (needed for any multiple number of flow meters purchased above)	130446X

*System part number will include fitting, electronic sensor and transmitter (one programmer is needed for any number of transmitters selected)

Ordering chart for sensor Type 8030

A flow sensor Type 8030 consists of:

- a sensor electronic module Type SE30
- an INLINE fitting Type S030 (Refer to page 7 or corresponding datasheet)

Specifications	Voltage supply	Output	Electrical connection	Item no.
Hall (Pulse) version sensor (pluggable to Types 8025 Universal transmitter, batch controller or konti-Dos; 8032; PLC)	12-36 V DC	Frequency with pulse, PNP or NPN	Cable plug	423 913
Hall (Pulse) "Low Power" version sensor (pluggable to Types 8025, 8032 remote version)	from associated transmitter	Frequency with pulse, NPN	Cable plug	423 914
Hall (Pulse) "Low Voltage" version sensor (pluggable to PLC)	5-15 V DC	Frequency with pulse, NPN	Cable plug	554 723

Ordering chart for accessories (to be ordered separately)

Specifications	Item no.
DIN cable plug EN 175301-803 with cable gland (Type 2508)	438 811
DIN cable plug EN 175301-803 with 1/2" NPT conduit (Type 2509)	162 673
1/2" conduit ring for converting cable DIN plug	014 132

Interconnection possibilities with the sensor Type 8030

